

LIB # 13872

2 OF 2

ESC 3234 95 01
Service Manual

Tektronix

2205
Oscilloscope
070-6716-00

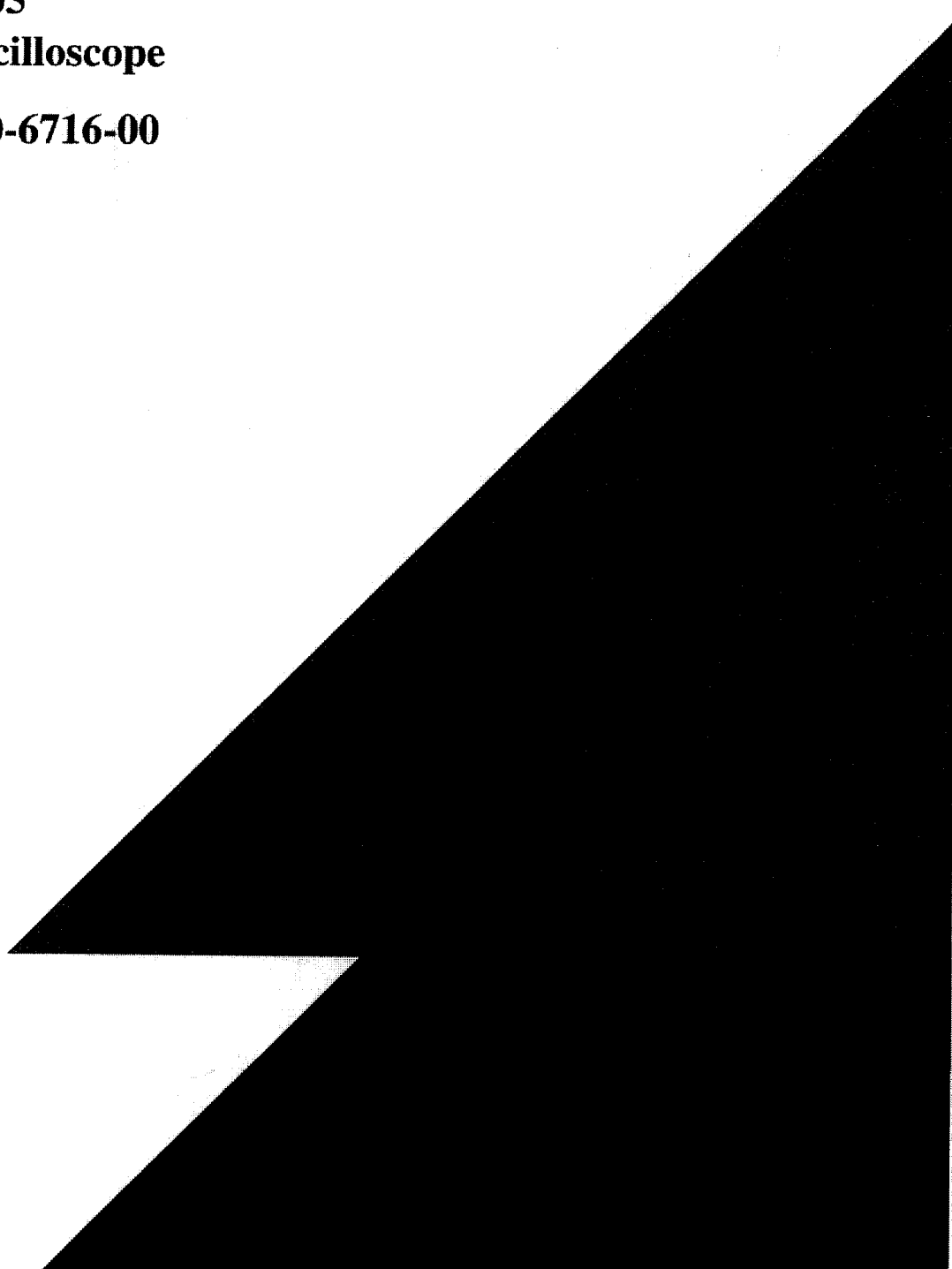

1954
1955
1956
1957
1958
1959
1960
1961
1962
1963
1964
1965
1966
1967
1968
1969
1970
1971
1972
1973
1974
1975
1976
1977
1978
1979
1980
1981
1982
1983
1984
1985
1986
1987
1988
1989
1990
1991
1992
1993
1994
1995
1996
1997
1998
1999
2000
2001
2002
2003
2004
2005
2006
2007
2008
2009
2010
2011
2012
2013
2014
2015
2016
2017
2018
2019
2020
2021
2022
2023
2024
2025
2026
2027
2028
2029
2030

1954
1955
1956
1957
1958
1959
1960
1961
1962
1963
1964
1965
1966
1967
1968
1969
1970
1971
1972
1973
1974
1975
1976
1977
1978
1979
1980
1981
1982
1983
1984
1985
1986
1987
1988
1989
1990
1991
1992
1993
1994
1995
1996
1997
1998
1999
2000
2001
2002
2003
2004
2005
2006
2007
2008
2009
2010
2011
2012
2013
2014
2015
2016
2017
2018
2019
2020
2021
2022
2023
2024
2025
2026
2027
2028
2029
2030

1954
1955
1956
1957
1958
1959
1960
1961
1962
1963
1964
1965
1966
1967
1968
1969
1970
1971
1972
1973
1974
1975
1976
1977
1978
1979
1980
1981
1982
1983
1984
1985
1986
1987
1988
1989
1990
1991
1992
1993
1994
1995
1996
1997
1998
1999
2000
2001
2002
2003
2004
2005
2006
2007
2008
2009
2010
2011
2012
2013
2014
2015
2016
2017
2018
2019
2020
2021
2022
2023
2024
2025
2026
2027
2028
2029
2030

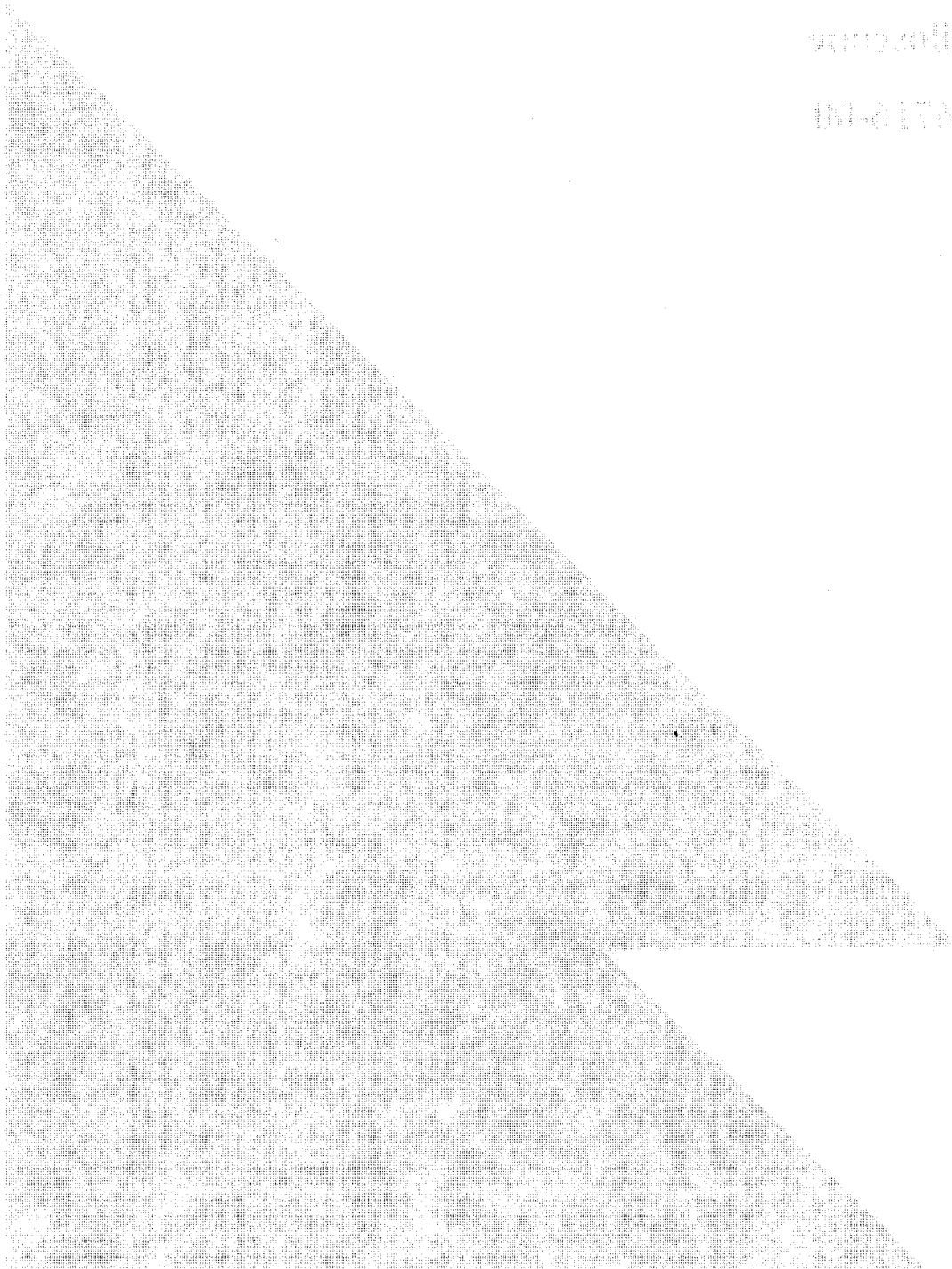

Service Manual

Tektronix

2205

Oscilloscope

070-6716-00

Warning

The servicing instructions are for use by qualified personnel only. To avoid personal injury, do not perform any servicing unless you are qualified to do so. Refer to the Safety Summary prior to performing service.

Please check for change information at the rear of this manual.

First Printing: April 1988

Instrument Serial Numbers

Each instrument manufactured by Tektronix has a serial number on a panel insert or tag, or stamped on the chassis. The first letter in the serial number designates the country of manufacture. The last five digits of the serial number are assigned sequentially and are unique to each instrument. Those manufactured in the United States have six unique digits. The country of manufacture is identified as follows:

B010000	Tektronix, Inc., Beaverton, Oregon, USA
E200000	Tektronix United Kingdom, Ltd., London
J300000	Sony/Tektronix, Japan
H700000	Tektronix Holland, NV, Heerenveen, The Netherlands

Instruments manufactured for Tektronix by external vendors outside the United States are assigned a two digit alpha code to identify the country of manufacture (e.g., JP for Japan, HK for Hong Kong, IL for Israel, etc.).

Tektronix, Inc., P.O. Box 500, Beaverton, OR 97077

Printed in U.S.A.

Copyright © Tektronix, Inc., 1988. All rights reserved. Tektronix products are covered by U.S. and foreign patents, issued and pending. The following are registered trademarks: TEKTRONIX, TEK, TEKPROBE, and SCOPE-MOBILE.

WARRANTY

Tektronix warrants that this product will be free from defects in materials and workmanship for a period of one (1) year from the date of shipment. If any such product proves defective during this warranty period, Tektronix, at its option, either will repair the defective product without charge for parts and labor, or will provide a replacement in exchange for the defective product.

In order to obtain service under this warranty, Customer must notify Tektronix of the defect before the expiration of the warranty period and make suitable arrangements for the performance of service. Customer shall be responsible for packaging and shipping the defective product to the service center designated by Tektronix, with shipping charges prepaid. Tektronix shall pay for the return of the product to Customer if the shipment is to a location within the country in which the Tektronix service center is located. Customer shall be responsible for paying all shipping charges, duties, taxes, and any other charges for products returned to any other locations.

This warranty shall not apply to any defect, failure or damage caused by improper use or improper or inadequate maintenance and care. Tektronix shall not be obligated to furnish service under this warranty a) to repair damage resulting from attempts by personnel other than Tektronix representatives to install, repair or service the product; b) to repair damage resulting from improper use or connection to incompatible equipment; or c) to service a product that has been modified or integrated with other products when the effect of such modification or integration increases the time or difficulty of servicing the product.

THIS WARRANTY IS GIVEN BY TEKTRONIX WITH RESPECT TO THIS PRODUCT IN LIEU OF ANY OTHER WARRANTIES, EXPRESSED OR IMPLIED. TEKTRONIX AND ITS VENDORS DISCLAIM ANY IMPLIED WARRANTIES OF MERCHANTABILITY OR FITNESS FOR A PARTICULAR PURPOSE. TEKTRONIX' RESPONSIBILITY TO REPAIR OR REPLACE DEFECTIVE PRODUCTS IS THE SOLE AND EXCLUSIVE REMEDY PROVIDED TO THE CUSTOMER FOR BREACH OF THIS WARRANTY. TEKTRONIX AND ITS VENDORS WILL NOT BE LIABLE FOR ANY INDIRECT, SPECIAL, INCIDENTAL, OR CONSEQUENTIAL DAMAGES IRRESPECTIVE OF WHETHER TEKTRONIX OR THE VENDOR HAS ADVANCE NOTICE OF THE POSSIBILITY OF SUCH DAMAGES.

Certificate of the Manufacturer/Importer

We hereby certify that the 2205 PORTABLE OSCILLOSCOPE

AND ALL INSTALLED OPTIONS

complies with the RF Interference Suppression requirements of Amtsbl.-Vfg 1046/1984.

The German Postal Service was notified that the equipment is being marketed.

The German Postal Service has the right to re-test the series and to verify that it complies.

TEKTRONIX

Bescheinigung des Herstellers/Importeurs

Hiermit wird bescheinigt, daß der/die/das 2205 PORTABLE OSCILLOSCOPE

AND ALL INSTALLED OPTIONS

in Übereinstimmung mit den Bestimmungen der Amtsblatt-Verfügung 1046/1984 funktentstört ist.

Der Deutschen Bundespost wurde das Inverkehrbringen dieses Gerätes angezeigt und die Berechtigung zur Überprüfung der Serie auf Einhalten der Bestimmungen eingeräumt.

TEKTRONIX

NOTICE to the user/operator:

The German Postal Service requires that Systems assembled by the operator/user of this instrument must also comply with Postal Regulation, Vfg. 1046/1984, Par. 2, Sect. 1.

HINWEIS für den Benutzer/Betreiber:

Die vom Betreiber zusammengestellte Anlage, innerhalb derer dies Gerät eingesetzt wird, muß ebenfalls den Voraussetzungen nach Par. 2, Ziff. 1 der Vfg. 1046/1984 genügen.

NOTICE to the user/operator:

The German Postal Service requires that this equipment, when used in a test setup, may only be operated if the requirements of Postal Regulation, Vfg. 1046/1984, Par. 2, Sect. 1.7.1 are complied with.

HINWEIS für den Benutzer/Betreiber:

Dies Gerät darf in Meßaufbauten nur betrieben werden, wenn die Voraussetzungen des Par. 2, Ziff. 1.7.1 der Vfg. 1046/1984 eingehalten werden.

TABLE OF CONTENTS

	Page		Page
LIST OF ILLUSTRATIONS	iv	GRATICULE	2-7
LIST OF TABLES	v	CONNECTING SIGNALS	2-7
OPERATORS SAFETY SUMMARY	vi	OPERATOR'S CHECKS AND ADJUSTMENTS	2-8
SERVICING SAFETY SUMMARY	vii	INITIAL SETUP	2-8
		TRACE ROTATION ADJUSTMENT	2-8
Section 1 SPECIFICATION		PROBE COMPENSATION (Option 10X Probe)	2-9
INTRODUCTION	1-1		
ACCESSORIES	1-1	Section 3 THEORY OF OPERATION	
PERFORMANCE CONDITIONS ..	1-1	SECTION ORGANIZATION	3-1
		INTEGRATED CIRCUIT DESCRIPTIONS	3-1
Section 2 OPERATING INFORMATION		GENERAL DESCRIPTION	3-1
PREPARATION FOR USE	2-1	DETAILED CIRCUIT DESCRIPTION	3-3
SAFETY	2-1	VERTICAL	3-3
LINE VOLTAGE SELECTION	2-1	TRIGGER AMPLIFIERS AND SWITCHING	3-6
LINE FUSE	2-1	TRIGGER GENERATOR	3-8
INSTRUMENT COOLING	2-1	SWEEP GENERATOR AND LOGIC	3-9
CONTROLS, CONNECTORS, AND INDICATORS	2-3	HORIZONTAL	3-11
POWER AND DISPLAY	2-3	Z-AXIS AMPLIFIER	3-12
VERTICAL	2-3	POWER SUPPLY AND PROBE ADJUST	3-14
HORIZONTAL	2-5		
TRIGGER	2-5		
REAR PANEL	2-6		
OPERATING CONSIDERATIONS ...	2-7		

TABLE OF CONTENTS (cont)

	Page		Page
Section 4		Section 5	
PERFORMANCE CHECK PROCEDURE		ADJUSTMENT PROCEDURE	
INTRODUCTION	4-1	INTRODUCTION	5-1
PURPOSE	4-1	PURPOSE	5-1
PERFORMANCE CHECK		STRUCTURE	5-1
INTERVAL	4-1	TEST EQUIPMENT	
STRUCTURE	4-1	REQUIRED	5-1
TEST EQUIPMENT		LIMITS AND TOLERANCES	5-1
REQUIRED	4-1	ADJUSTMENTS AFFECTED B	
LIMITS AND TOLERANCES	4-1	REPAIRS	5-1
PREPARATION FOR		PREPARATION FOR	
CHECKS	4-1	ADJUSTMENT	5-1
INDEX TO PERFORMANCE		INDEX TO ADJUSTMENT	
CHECK STEPS	4-3	PROCEDURE STEPS	5-3
VERTICAL	4-4	POWER SUPPLY AND	
INITIAL CONTROL		CRT DISPLAY	5-4
SETTINGS	4-4	INITIAL CONTROL	
PROCEDURE STEPS	4-4	SETTINGS	5-4
HORIZONTAL	4-6	PROCEDURE STEPS	5-4
INITIAL CONTROL		VERTICAL	5-6
SETTINGS	4-6	INITIAL CONTROL	
PROCEDURE STEPS	4-6	SETTINGS	5-6
TRIGGER	4-9	PROCEDURE STEPS	5-6
INITIAL CONTROL		HORIZONTAL	5-12
SETTINGS	4-9	INITIAL CONTROL	
PROCEDURE STEPS	4-9	SETTINGS	5-12
EXTERNAL Z-AXIS AND		PROCEDURE STEPS	5-12
PROBE ADJUST	4-12	TRIGGER	5-16
INITIAL CONTROL		INITIAL CONTROL	
SETTINGS	4-12	SETTINGS	5-16
PROCEDURE STEPS	4-12	PROCEDURE STEPS	5-16
		EXTERNAL Z-AXIS AND	
		PROBE ADJUST	5-19
		INITIAL CONTROL	
		SETTINGS	5-19
		PROCEDURE STEPS	5-19

TABLE OF CONTENTS (cont)

	Page		Page
Section 6 MAINTENANCE		TRANSISTORS AND INTEGRATED CIRCUITS	6-12
STATIC-SENSITIVE COMPONENTS	6-1	SOLDERING TECHNIQUES	6-12
PREVENTIVE MAINTENANCE	6-2	REMOVAL AND REPLACEMENT INSTRUCTIONS	6-13
INTRODUCTION	6-2		
GENERAL CARE	6-2	Section 7 OPTIONS AND ACCESSORIES	
INSPECTION AND CLEANING	6-2	OPTION 1C	7-1
LUBRICATION	6-4	OPTION 1K	7-1
SEMICONDUCTOR CHECKS	6-4	OPTION 1R	7-1
PERIODIC READJUSTMENT	6-4	OPTION 1T	7-1
TROUBLESHOOTING	6-5	OPTION 02	7-1
INTRODUCTION	6-5	OPTION 22	7-1
TROUBLESHOOTING AIDS	6-5	OPTION 23	7-2
TROUBLESHOOTING EQUIPMENT	6-6	OPTION 24	7-2
TROUBLESHOOTING TECHNIQUES	6-6	INTERNATIONAL POWER CORDS	7-2
CORRECTIVE MAINTENANCE	6-10	OPTIONAL ACCESSORIES	7-2
INTRODUCTION	6-10	STANDARD ACCESSORIES	7-4
MAINTENANCE PRECAUTIONS	6-10		
OBTAINING REPLACEMENT PARTS	6-10	Section 8 REPLACEABLE ELECTRICAL PARTS	
MAINTENANCE AIDS	6-10	Section 9 DIAGRAMS	
RIBBON-CABLE CONNECTIONS	6-11	Section 10 REPLACEABLE MECHANICAL PARTS	
		CHANGE INFORMATION	

LIST OF ILLUSTRATIONS

Figure	Page
The 2205 Oscilloscope	viii
1-1 Maximum input voltage vs frequency derating curve for CH 1 OR X, CH 2 OR Y, and EXT INPUT OR Z connectors	1-7
1-2 Instrument dimensional drawing	1-8
2-1 Voltage Selector switch, fuse, power-cord receptacle, and plastic clamp	2-2
2-2 Front panel controls, connectors, and indicators	2-4
2-3 Rear Panel	2-6
2-4 Graticule measurement markings	2-7
2-5 Probe compensation	2-9
3-1 Block diagram of the Channel 1 Attenuator	3-3
3-2 Block diagram of the Channel Switching	3-5
3-3 Block diagram of the Sweep Generator and Logic	3-9
3-4 Block diagram of the Horizontal Amplifier	3-11
3-5 Simplified diagram of the DC Restorer	3-13
3-6 Block diagram of the Power Supply	3-15
5-1 Attenuator trimmer adjustments	5-8
6-1 Multi-connector holder orientation	6-12
9-1 Color codes for resistors.	
9-2 Semiconductor lead configurations.	
9-3 Locating components on schematic diagrams and circuit board illustrations.	
9-4 Block diagram.	
9-5 Component view of A3—Front Panel board.	
9-6 Circuit view of A3—Front Panel board.	
9-7 A2—Timebase/Attenuator board.	
9-8 A1—Main board component view.	
9-9 Circuit view of A1—Main board.	
9-10 A4—Mains Input board.	
9-11 Adjustment locations of A1—Main board component view.	
9-12 Adjustment locations of A1—Main board circuit view.	
9-13 A2—Timebase/Attenuator board adjustment locations.	
9-14 A3—Front Panel board adjustment location.	

LIST OF TABLES

Table	Page
1-1 Electrical Characteristics	1-2
1-2 Environmental Characteristics	1-6
1-3 Mechanical Characteristics	1-7
4-1 Test Equipment Required	4-2
4-2 Deflection Accuracy Limits	4-4
4-3 Settings for Timing Accuracy Checks	4-7
4-4 Switch Combinations for Triggering Checks	4-9
5-1 Adjustments Affected by Repairs	5-2
5-2 Power Supply Limits	5-4
5-3 Deflection Accuracy Limits	5-7
5-4 Settings for Timing Accuracy Checks	5-14
5-5 Settings for Holdoff Checks	5-15
5-6 Switch Combinations for Triggering Checks	5-17
6-1 Relative Susceptibility to Static-Discharge Damage	6-1
6-2 External Inspection Checklist	6-3
6-3 Internal Inspection Checklist	6-4
6-4 Power Supply Voltage and Ripple Limits	6-7
6-5 Maintenance Aids	6-11
7-1 International Power Cords and Fuses	7-2
7-2 Optional Accessories	7-3

OPERATORS SAFETY SUMMARY

The general safety information in this part of the summary is for both operating and service personnel. Specific warnings and cautions will be found throughout the manual where they apply and do not appear in this summary.

Terms in this Manual

CAUTION statements identify conditions or practices that could result in damage to the equipment or other property.

WARNING statements identify conditions or practices that could result in personal injury or loss of life.

Terms as Marked on Equipment

CAUTION indicates a personal injury hazard not immediately accessible as one reads the markings, or a hazard to property, including the equipment itself.

DANGER indicates a personal injury hazard immediately accessible as one reads the marking.

Symbols in this Manual



This symbol indicates where applicable cautionary or other information is to be found. For maximum input voltage see Table 1-1.

Symbols as Marked on Equipment



Protective ground (earth) terminal.



ATTENTION—Refer to manual.

Power Source

This product is intended to operate from a power source that does not apply more than 250 V rms between the supply conductors or between either supply conductor and ground. A protective ground connection, by way of the grounding conductor in the power cord, is essential for safe operation.

Grounding the Product

This product is grounded through the grounding conductor of the power cord. To avoid electrical shock, plug the power cord into a properly wired receptacle before making any connections to the product input or output terminals. A protective ground connection, by way of the grounding conductor in the power cord, is essential for safe operation.

Danger Arising From Loss of Ground

Upon loss of the protective-ground connection, all accessible conductive parts, including knobs and controls that may appear to be insulating, can render an electric shock.

Use the Proper Power Cord

Use only the power cord and connector specified for your product.

Use only a power cord that is in good condition.

For detailed information on power cords and connectors, see Figure 2-2.

Use the Proper Fuse

To avoid fire hazard, use only a fuse of the correct type, voltage rating and current rating as specified in the parts list for your product.

Do Not Operate in Explosive Atmosphere

To avoid explosion, do not operate this instrument in an explosive atmosphere.

Do Not Remove Covers or Panels

To avoid personal injury, do not remove the product covers or panels. Do not operate the product without the covers and panels properly installed.

SERVICING SAFETY SUMMARY

FOR QUALIFIED SERVICE PERSONNEL ONLY

Refer also to the preceding Operators Safety Summary

Do Not Service Alone

Do not perform internal service or adjustment of this product unless another person capable of rendering first aid and resuscitation is present.

Use Care When Servicing With Power On

Dangerous voltages exist at several points in this product. To avoid personal injury, do not touch exposed connections or components while power is on.

Disconnect power before removing protective panels, soldering, or replacing components.

Power Source

This product is intended to operate from a power source that does not apply more than 250 volts rms between the supply conductors or between either supply conductor and ground. A protective ground connection by way of the grounding connector in the power cord is essential for safe operation.

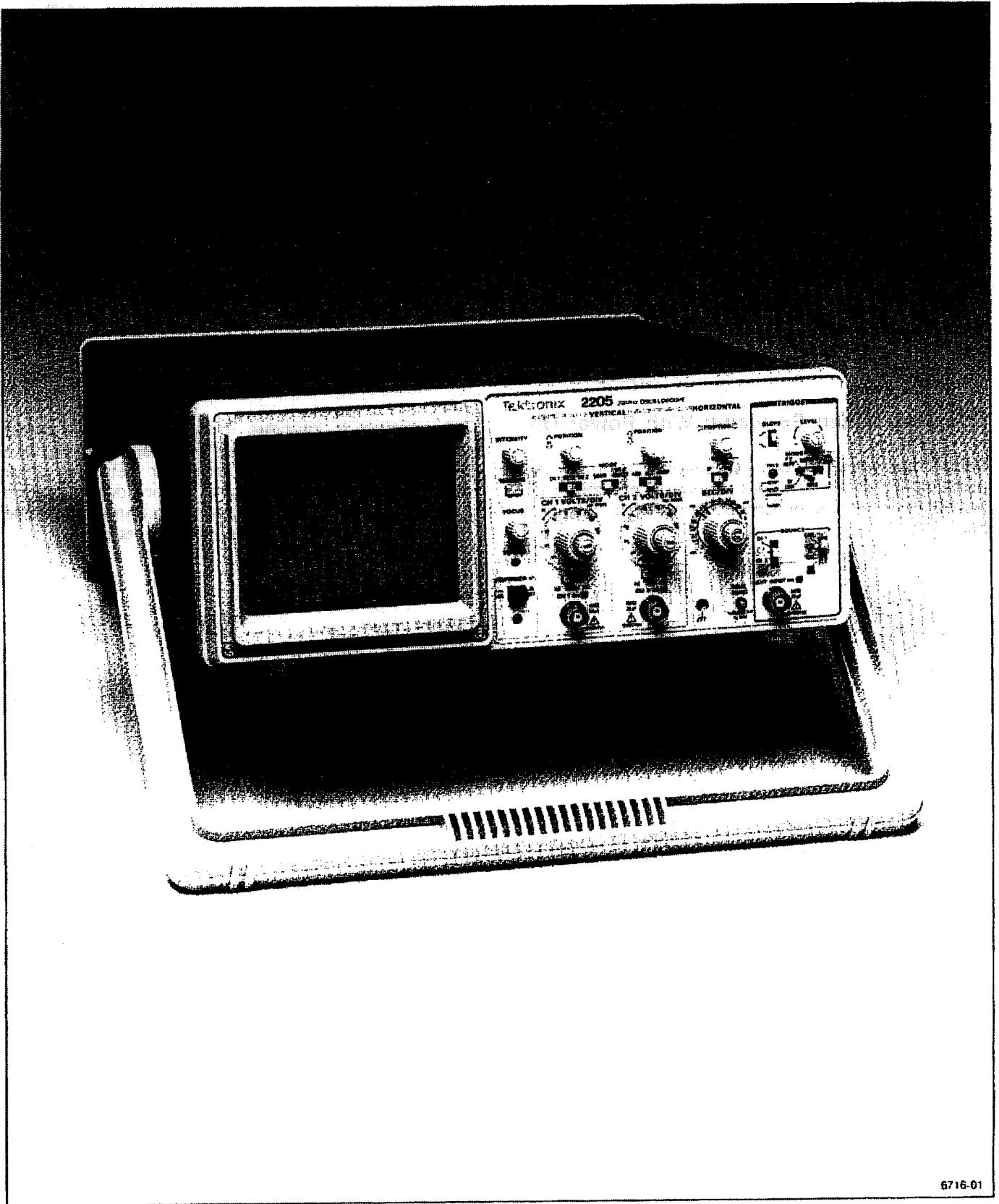

6716-01

The 2205 Oscilloscope.

SPECIFICATION

INTRODUCTION

The TEKTRONIX 2205 Oscilloscope is a rugged, lightweight, dual-channel, 20 MHz instrument that features a bright, sharply defined trace on an 80 by 100 mm cathode-ray tube (crt).

Its low-noise vertical system supplies calibrated deflection factors from 5 mV to 5 V per division at full bandwidth.

Stable triggering is achieved over the full bandwidth of the vertical system. The flexibility and high sensitivity of the trigger system provides a range of conveniences such as hands-free triggering with the peak-to-peak automatic mode, independent selection of TV line and TV field triggering at any sweep speed, and single-sweep triggering. The trigger signal is dc coupled. An external triggering signal or an external Z-axis modulation signal can be applied via a front-panel connector and the source-selector switches.

The horizontal system provides calibrated sweep speeds from 0.5 s to 100 ns per division. For greater measurement accuracy, a X10 magnifier circuit extends the maximum sweep speed to 10 ns per division.

ACCESSORIES

The instrument is shipped with the following accessories:

- 1 Operators Manual
- 2 1X Signal Adapters
- 1 Power Cord
- 2 Fuses
- 1 Power Cord Clamp
- 1 Washer
- 1 Screw

Part numbers for these standard accessories, as well as for other optional accessories, are located in Section 7, Options and Accessories. The voltage-sensing signal adapters were designed specifically to complement the performance of your 2205.

PERFORMANCE CONDITIONS

The 2205 electrical characteristics listed in Table 1-1 are valid when it has been adjusted at an ambient temperature between +20 C and +30 C, has had a warm-up period of at least 20 minutes, and is operating at an ambient temperature between 0 C and +40 C (unless otherwise noted).

Environmental characteristics are given in Table 1-2. The 2205 meets the requirements of MIL-T-28800C, paragraphs 4.5.5.1.3, 4.5.5.1.4, and 4.5.5.1.2.2 for Type III, Class 5 equipment, except where otherwise noted.

Mechanical characteristics of the instrument are listed in Table 1-3.

Table 1-1
Electrical Characteristics

Characteristics	Performance Requirements
VERTICAL DEFLECTION SYSTEM	
Deflection Factor Range	5 mV per division to 5 V per division in a 1-2-5 sequence of 9 steps.
Accuracy +15°C to +35°C	± 3%.
0°C to +15°C and +35°C to +40°C	± 5%.
Variable Control Range	Continuously variable and uncalibrated between step settings. Increases deflection factor by at least 2.5 to 1.
Step Response (Rise Time)	Applicable from 5 mV per division to 5 V per division. Rise times calculated from: $tr = \frac{0.35}{BW \text{ in MHz}}$
+5°C to +35°C	17.5 ns or less. ^a
0°C to +5°C and +35°C to +40°C	23.3 ns or less. ^a
Bandwidth (-3 dB) +5°C to +35°C	20 MHz or more.
0°C to +5°C and +35°C to +40°C	15 MHz or more. ^a
Ac Coupled Lower Cutoff Frequency	10 Hz or less at -3 dB. ^a
CHOP Mode Switching Rate	500 kHz ± 30%. ^a
Input Characteristics	
Resistance	1 MΩ ± 2%. ^a
Capacitance	25 pF ± 2%. ^a
Maximum Safe Input Voltage (DC or AC Coupled) 	400 V (dc + peak ac) or 800 V ac p-p to 10 kHz or less. ^a
Common-mode Rejection Ratio (CMRR)	At least 10 to 1 at 10 MHz.
Trace Shift	
With VOLTS/DIV Switch Rotation	0.75 division or less (Variable control in CAL detent). ^a
With VOLTS/DIV Variable Control Rotation	1 division or less. ^a
With Channel 2 Inverted	1.5 division or less. ^a
Channel Isolation	Greater than 100:1 at 20 MHz.

^aPerformance requirement not checked in manual.

Table 1-1 (cont)

Characteristics	Performance Requirements	
TRIGGER SYSTEM		
Trigger Sensitivity		
P-P AUTO/TV LINE and NORM Modes	5 MHz	30 MHz
Internal Signal	0.3 div	1.0 div
External Signal	40 mV	150 mV
Lowest Usable Frequency in P-P AUTO Mode	≥ 20 Hz. ^a	
TV FIELD Mode	1.0 division of composite sync. ^a	
External Input		
Resistance	1 M Ω $\pm 10\%$. ^a	
Capacitance	25 pF ± 2.5 pF. ^a	
Maximum Input Voltage 	400 V (dc + peak ac) or 800 V ac p-p at 10 kHz or less. ^a	
Trigger Level Range		
NORM Mode	± 15 division referred to the appropriate vertical input.	
EXT Source	At least ± 1.6 V, 3.2 V p-p.	
EXT/10 Source	At least ± 16 V, 32 V p-p. ^a	
HORIZONTAL DEFLECTION SYSTEM		
Sweep Rate		
Calibrated Range	0.5 s per division to 0.1 μ s per division in a 1-2-5 sequence. Magnification extends maximum usable sweep speed to 10 ns per division. ^a	
Accuracy	Magnified	
	X1	X10
+15°C to +35°C	$\pm 3\%$	$\pm 4\%$
0°C to +15°C and +35°C to +40°C	$\pm 4\%$ ^a	$\pm 5\%$ ^a
	Sweep accuracy applies over the center eight divisions. Exclude the first 25 ns of the sweep for magnified sweep speeds and anything beyond the 100th magnified division.	

^aPerformance requirement not checked in manual.

Table 1-1 (cont)

Characteristics	Performance Requirements			
HORIZONTAL DEFLECTION SYSTEM (cont)				
Variable Control Range	Continuously variable and uncalibrated between calibrated step settings. Decreases calibrated sweep speeds at least by a factor of 2.5.			
Sweep Linearity	Magnified			
	<table border="1" style="width: 100%; border-collapse: collapse;"> <tr> <td style="width: 50%; text-align: center;">X1</td> <td style="width: 50%; text-align: center;">X10</td> </tr> <tr> <td style="text-align: center;">±5%</td> <td style="text-align: center;">±7%</td> </tr> </table>	X1	X10	±5%
X1	X10			
±5%	±7%			
POSITION Control Range	Start of sweep to 10th division in X1, and to 100th division in X10, will position past the center vertical graticule line.			
Registration of Unmagnified and Magnified Traces	0.2 division or less, aligned to center vertical graticule line. ^a			
Z-MODULATION				
Sensitivity	5 V causes noticeable modulation. Positive-going input decreases intensity.			
Usable frequency range	Dc to 5 MHz. ^a			
Maximum Safe Input Voltage 	400 V (dc + peak ac) or 800 V ac p-p to 10 kHz or less. ^a			
X-Y OPERATION (X1 MODE)				
Deflection Factors	Same as vertical deflection system with variable controls in the CAL detents. ^a			
Accuracy X-Axis	±5%.			
Y-Axis	Same as Vertical Deflection System. ^a			
Bandwidth (-3 dB) X-Axis	Dc to at least 1 MHz.			
Y-Axis	Same as Vertical Deflection System. ^a			
Phase difference between X- and Y-Axis Amplifiers	±3° from dc to 50 kHz. ^a			
PROBE ADJUST SIGNAL OUTPUT				
Voltage into 1 MΩ Load	0.5 V ±5%.			
Repetition Rate	1 kHz ±20%. ^a			

^aPerformance requirement not checked in manual.

Table 1-1 (cont)

Characteristics	Performance Requirements
POWER REQUIREMENTS	
Line Voltage Ranges	
115 V Setting	95 Vac to 128 Vac. ^a
230 V Setting	185 Vac to 150 Vac. ^a
Line Frequency	48 Hz to 440 Hz. ^a
Maximum Power Consumption	40 W (60 VA). ^a
Line Fuse	UL 198.6 3AG (1/4 X 1 1/4 inch)
115 V Setting	0.75 A, Slow.
230 V Setting	0.5 A, Slow.
CATHODE-RAY TUBE	
Display Area	8 X 100 mm. ^a
Standard Phosphor	GH (P31). ^a
Nominal Accelerating Voltage	1800 V \pm 10%. ^a

^aPerformance requirement not checked in manual.

Table 1-2
Environmental Characteristics

Characteristics	Performance Requirements
Temperature Operating	0°C to +40°C (+32°F to +104°F).
Nonoperating	-55°C to +75°C (-67°F to +167°F). Tested to MIL-T-28800C, paragraphs 4.5.5.1.3 and 4.5.5.1.4, except in 4.5.5.1.3 steps 4 and 5 (0°C operating test) are performed ahead of step 2 (-55°C nonoperating test). Equipment shall remain off upon return to room ambient during step 6. Excessive condensation shall be removed before operating during step 7.
Altitude Operating	To 4,570 meters (15,000 feet). Maximum operating temperature decreased 1°C per 300 m (1000 feet) above 1500 m (5,000 feet).
Nonoperating	To 15,250 meters (50,000 feet).
Relative Humidity Operating (+30°C to +40°C)	85%, +0%, -5%.
Nonoperating (+30°C to +60°C)	85%, +0%, -5%.
Vibration Operating	15 minutes along each of three major axes at a total displacement of 0.015 inch p-p (2.4 g at 55 Hz) with frequency varied from 10 Hz to 55 Hz to 10 Hz in one minute sweeps. Hold for 10 minutes at 55 Hz in each of three major axes. All major resonances must be above 55 Hz.
Shock Operating and Nonoperating	30 g, half-sine, 11-ms duration, three shocks per axis each direction, for a total of 18 shocks.
Radiated and conducted emission requirements	Meets VDE 0871, Class B and FCC Regulations.

Table 1-3
Mechanical Characteristics

Characteristics	Description
Weight with Power Cord	6.7 kg (14.8 lbs) or less.
Domestic Shipping Weight	9.1 kg (20.1 lbs) or less.
Dimensions	
Height	138 mm (5.4 in).
Width	
With Handle	380 mm (15.0 in).
Without Handle	327 mm (12.9 in).
Depth	
Without Front Cover	440 mm (17.2 in).
With Optional Front Cover	445 mm (17.5 in).
With Handle Extended	516 mm (20.3 in).

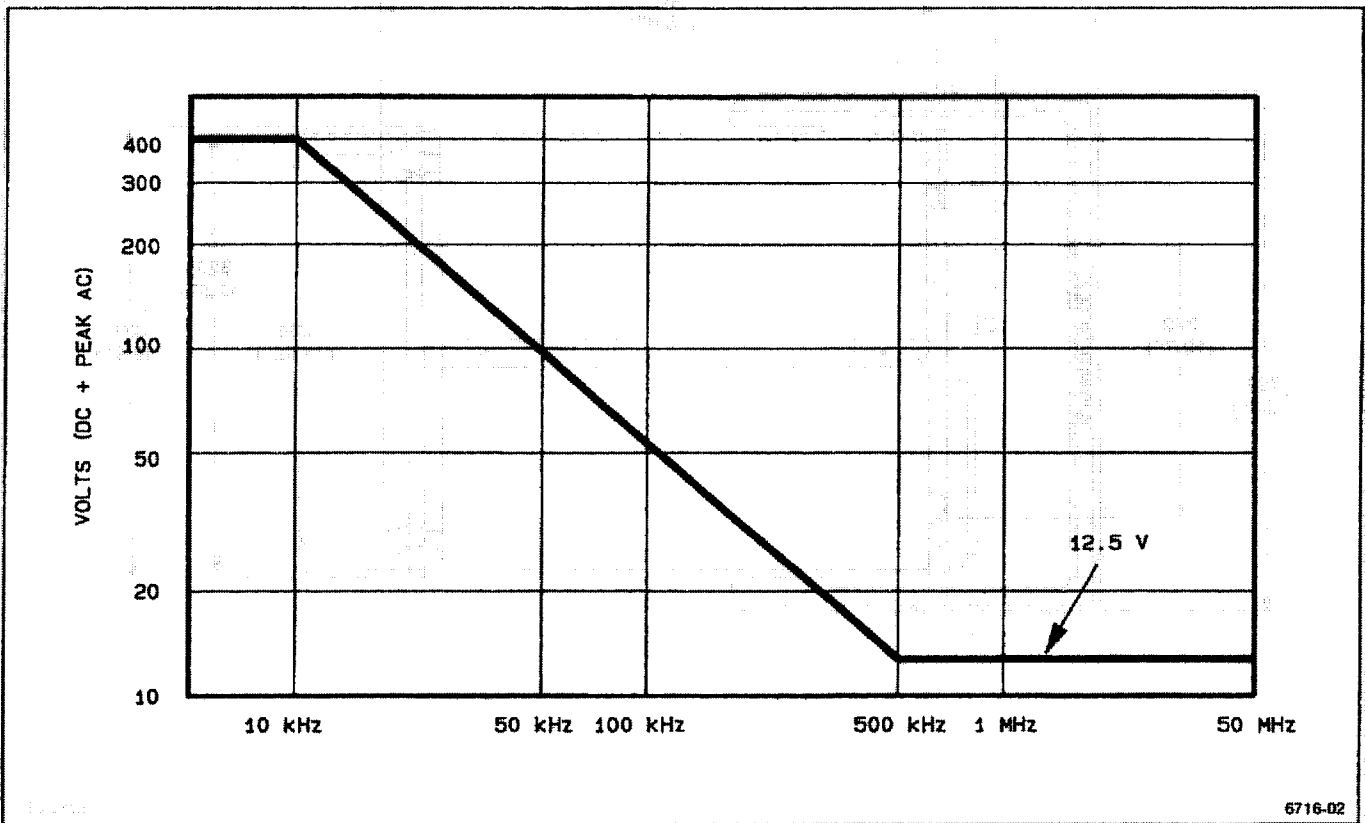
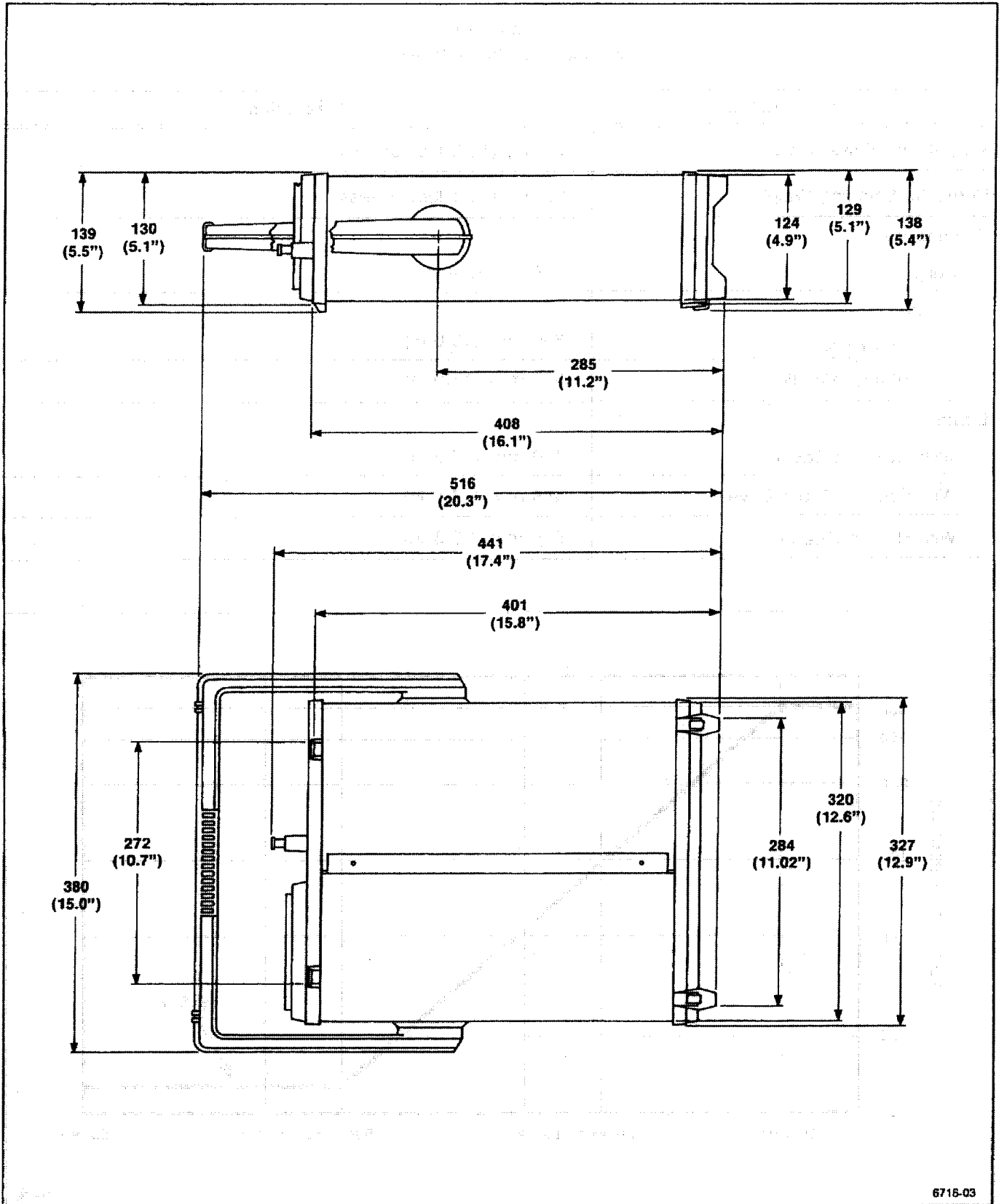

Figure 1-1. Maximum input voltage vs frequency derating curve for CH 1 OR X, CH 2 OR Y, and EXT INPUT OR Z connectors.



6715-03

Figure 1-2. Instrument dimensional drawing.

OPERATING INFORMATION

PREPARATION FOR USE

This part gives you important safety information and tells you how to proceed with initial start-up of the TEKTRONIX 2205 Oscilloscope.

SAFETY

Before connecting the 2205 Oscilloscope to a power source, read this entire section. Also refer to the Safety Summary at the front of this manual for power source, grounding, and other safety considerations pertaining to the use of the instrument. Ensure that you have the training required to safely connect inputs to the signals you will be measuring.

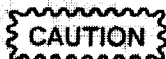

This instrument may be damaged if operated with the LINE VOLTAGE SELECTOR (on the rear panel) set for the wrong applied ac source voltage or if a wrong line fuse is installed.

LINE VOLTAGE SELECTION

The 2205 operates from either a 115-V or a 230-V nominal ac power line with any frequency from 48 Hz to 440 Hz. Before connecting the power cord to a power source, verify that the LINE VOLTAGE SELECTOR, located on the rear panel, is set correctly and that the proper line fuse is installed. Refer to Table 2-1, Figure 2-1, and the instrument rear panel.

To convert the 2205 for operation on the other line-voltage range, use a flat-bladed screwdriver to move the LINE VOLTAGE SELECTOR to the required position and install the appropriate fuse (listed on the rear panel and in Table 7-1). The detachable power cord may have to be replaced to match the particular power source.

LINE FUSE

The fuse holder is located on the rear panel and contains the line (mains) fuse. Use the following

procedure to verify that the proper fuse is installed or to install a replacement fuse.

1. Unplug the power cord from the power source (if applicable).
2. Press in and slightly rotate the fuse-holder cap counterclockwise to release it.
3. Pull the cap (with the fuse) out of the fuse holder.
4. Verify that the fuse is the same type listed on the back of the instrument. The two types of fuses listed are not directly interchangeable; they require different types of fuse caps.
5. Reinstall the fuse (or replacement fuse) in the fuse-holder cap.
6. Replace the fuse holder and cap.

This instrument has a detachable, three-wire power cord with a three-contact plug for connection to both the power source and protective ground. The ground contact on the plug connects through the power-cord to the external metal parts of the instrument. The power cord may be secured to the rear panel by a cord-set-securing clamp as shown in Figure 2-1. For electrical shock protection, insert this plug only into a power source outlet that has a properly grounded protective-ground contact.

Instruments are shipped with the required power cord as ordered by the customer. Power cord plug information is presented in Table 2-1, and part numbers are listed in Table 7-1.

INSTRUMENT COOLING

Maintain adequate airflow to prevent instrument damage from internally generated heat. Before turning on the power, check that the spaces around the air-intake holes on the sides of the cabinet are free of any obstruction to airflow.

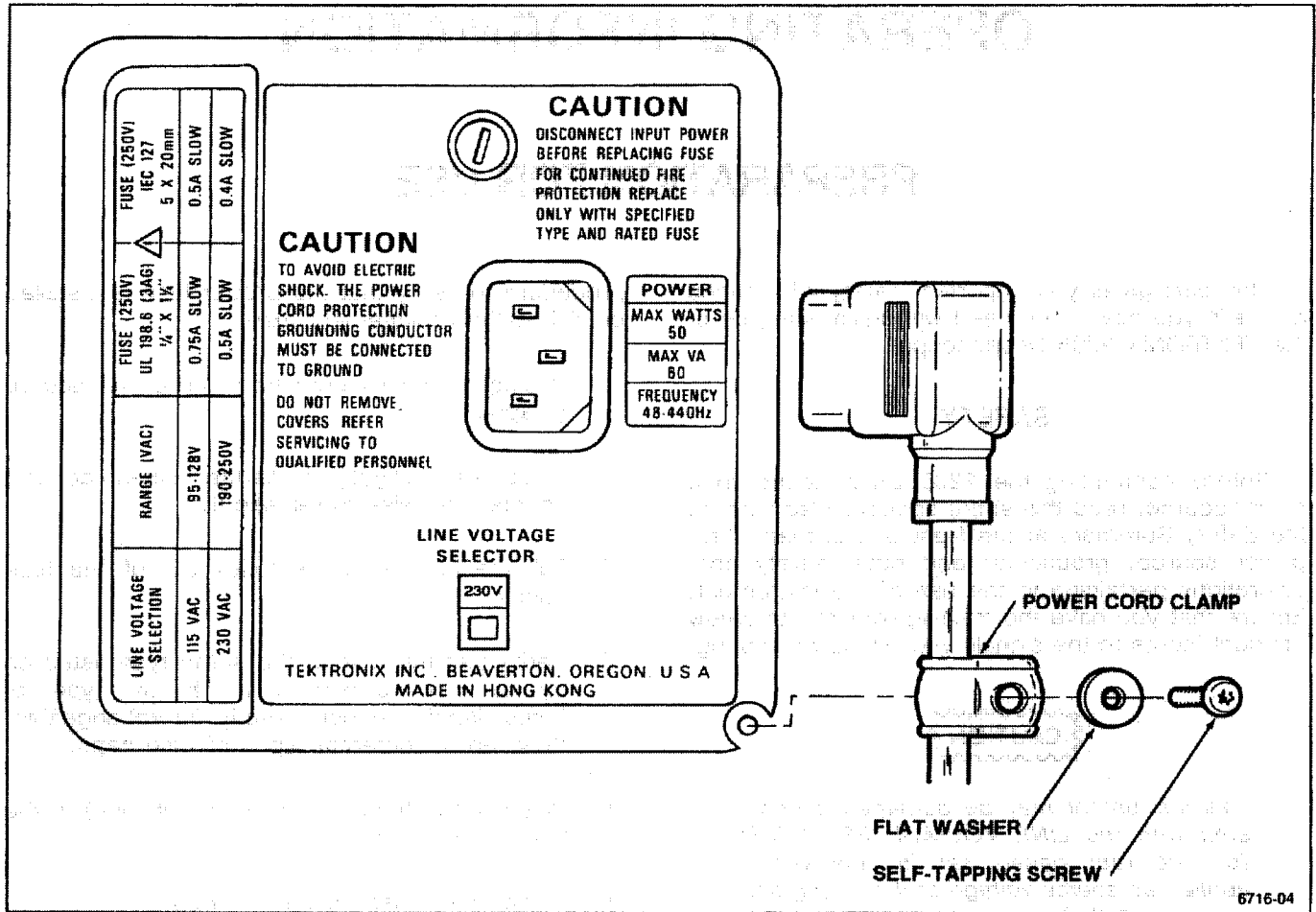

Figure 2-1. Voltage Selector switch, fuse, power-cord receptacle, and plastic clamp.

CONTROLS, CONNECTORS, AND INDICATORS

The following descriptions are intended to familiarize the operator with the location and function of the instrument's controls, connectors, and indicators.

Refer to Figure 2-2 for the location of items 1 through 28.

POWER AND DISPLAY

- ① **INTENSITY Control**—Adjusts the brightness of all displayed waveforms.
- ② **BEAM FIND Button**—Compresses the vertical and horizontal deflection to within the graticule area and intensifies the display to aid the user in locating traces that are overscanned or deflected outside of the crt viewing area.
- ③ **FOCUS Control**—Adjusts for optimum display definition. Once set, proper focusing is maintained over a wide range of display intensity.
- ④ **TRACE ROTATION Control**—Permits alignment of the trace with the horizontal graticule line. This control is a screwdriver adjustment that, once set, should require little attention during normal operation.
- ⑤ **POWER Switch**—Turns instrument power on or off.
- ⑥ **Power On Indicator**—Lights up while instrument is operating.

VERTICAL

- ⑦ **Channel 1 Vertical POSITION Control**—Controls the vertical display position of the Channel 1 signal. In X-Y mode the control is inactive.
- ⑧ **Channel 2 Vertical POSITION Control**—Controls the vertical display position of the Channel 2 signal. In X-Y mode the control vertically positions the display.
- ⑨ **MODE Switch CH 1-BOTH-CH 2**—Selects either a single channel for display or the dual-channel display mode.

CH 1—Selects only the Channel 1 input signal for display.

BOTH—Selects a combination of Channel 1 and Channel 2 input signals for display. The CH 1-BOTH-CH 2 switch must be in the BOTH position for ADD, ALT, and CHOP operation.

CH 2—Selects only the Channel 2 input signal for display.

- ⑩ **MODE Switch NORM-CH 2 INVERT**—Inverts the Channel 2 display when in the CH 2 INVERT position. With CH 2 inverted, the oscilloscope may be operated as a differential amplifier when the BOTH-ADD vertical mode is selected. For noninverting Channel 2 display, select NORM position.

- ⑪ **MODE Switch ADD-ALT-CHOP**—Sets the dual-channel vertical display mode.

ADD—Displays the sum of Channel 1 and Channel 2 input signals when BOTH is also selected. The difference of the Channel 1 and Channel 2 input signals is displayed when the Channel 2 signal is inverted.

ALT—Alternately displays the Channel 1 and Channel 2 input signals. The alternation occurs during retrace at the end of each sweep. ALT vertical mode is most useful for viewing both channel input signals at sweep rates of 0.5 ms per division and faster.

CHOP—Switches the display between the Channel 1 and Channel 2 vertical input signals during the sweep. The chopped switching rate (CHOP frequency) is approximately 500 kHz.

- ⑫ **CH 1 and CH 2 VOLTS/DIV Switches**—Select the vertical channel deflection factors from 5 mV to 5 V per division in a 1-2-5 sequence.

1X—Front-panel marking that indicates the deflection factor set by the VOLTS/DIV switch when a signal adapter, 1X probe, or a coaxial cable is attached to the channel input connector.

10X PROBE—Front-panel marking that indicates the deflection factor set by the VOLTS/DIV switch when a 10X probe is attached to the channel input connector.

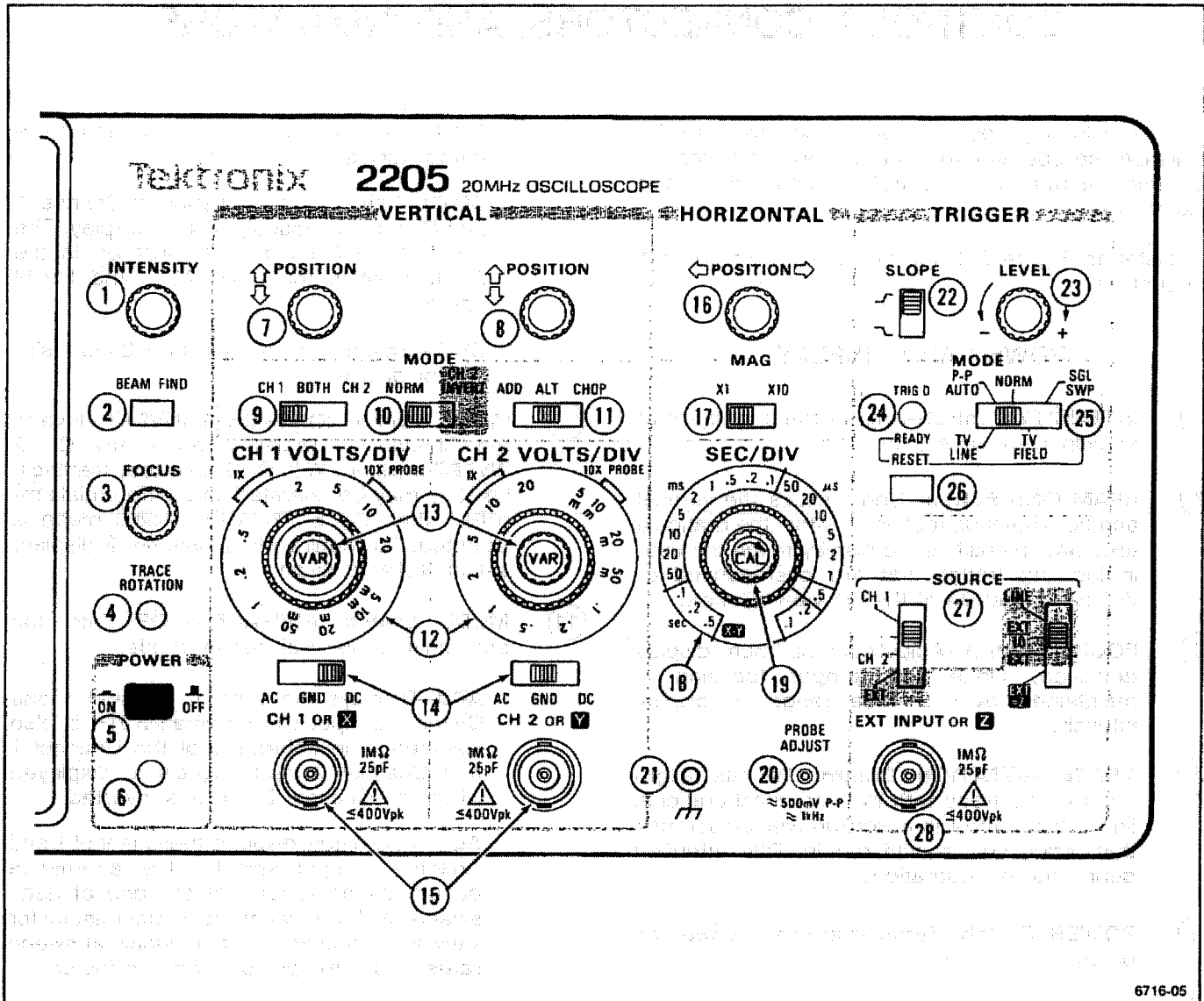

6716-05

Figure 2-2. Front panel controls, connectors, and indicators.

- 13** **Variable VOLTS/DIV Controls**—Provide continuously variable deflection factors between calibrated positions of the VOLTS/DIV switch. Reduces gain by at least 2.5 times at the fully counterclockwise rotation of the variable knob. A detent position at full clockwise rotation indicates the calibrated VOLTS/DIV position of the variable knob.
- 14** **AC-GND-DC (Input Coupling) Switches**—Select the method of coupling the input signal from the CH 1 OR X and CH 2 OR Y connectors to the vertical amplifiers.

 - AC**—Capacitively couples the input signal to the vertical deflection system. The dc component of the input signal is blocked. The lower -3 dB bandpass is 10 Hz or less.
 - GND**—Grounds the input of the vertical deflection channel; provides a zero (ground) reference voltage display (does not ground the input signal).
 - DC**—All frequency components of the input signal are coupled to the vertical deflection and signal acquisition systems.

- ⑮ **CH 1 OR X and CH 2 OR Y Input Connectors**—Provide for application of signals to the inputs of the deflection systems.

In X-Y mode, the signal connected to the CH 1 OR X input controls the horizontal deflection, and the signal connected to the CH 2 OR Y input controls the vertical deflection.

HORIZONTAL

- ⑯ **POSITION Control**—Positions the display horizontally in all modes.

- ⑰ **MAG Switch**—Selects X1 or X10 sweep speed.

X1—Normal sweep speed as selected by the SEC/DIV switch.

X10—Extends the SEC/DIV switch settings by a factor of 10. The fastest sweep speed can be extended to 10 ns per division.

- ⑱ **SEC/DIV Switch**—Selects calibrated sweep rates from 0.5 s to 0.01 μ s per division in a 1-2-5 sequence of 21 steps. The X-Y position selects the X-Y mode; the CH 1 OR X input signal produces horizontal deflection for X-Y displays, and the CH 2 OR Y input signal produces vertical deflection.

- ⑲ **Variable SEC/DIV Control**—Provide continuously variable, uncalibrated sweep speeds to at least 2.5 times slower than the calibrated setting. It extends the slowest sweep speed to at least 1.25 s per division.

- ⑳ **PROBE ADJUST Terminal**—Provides an approximately 0.5-V, negative-going, square-wave signal (at about 1 kHz) for use in compensating voltage probes and checking the vertical deflection system. The PROBE ADJUST output signal is not intended as a reference for checking either the vertical or the horizontal accuracy of the instrument.

- ㉑ **GND Connector (rh)**—Provides an auxiliary ground connection directly to the instrument chassis via a banana-tip jack.

TRIGGER

- ㉒ **SLOPE Switch**—Selects either the positive (\nearrow) or negative (\searrow) slope of the trigger signal to start the sweep.

- ㉓ **LEVEL Control**—Selects the amplitude point on the trigger signal that produces triggering.

- ㉔ **TRIG'D/READY Indicator**—A dual-function LED indicator. In P-P AUTO and NORM trigger modes, the indicator is turned on when triggering occurs. In SGL SWP trigger mode, the indicator turns on when the trigger circuit is armed, awaiting a triggering event; it turns off again as soon as the single sweep is triggered.

- ㉕ **Trigger MODE Switch**—Determines the sweep triggering mode.

P-P AUTO—TV LINE—Triggering occurs on trigger signals having adequate amplitude and a repetition rate of about 20 Hz or faster. In the absence of a proper trigger signal, an autotrigger is generated, and the sweep freeruns.

NORM—Permits triggering at all sweep rates (an autotrigger is not generated in the absence of an adequate trigger signal). NORM trigger mode is especially useful for low-frequency and low-repetition-rate signals.

TV FIELD—Permits stable triggering on a television field signal (vertical sync). In the absence of an adequate trigger signal, the sweep freeruns. The instrument otherwise behaves as in P-P AUTO.

SGL SWP—Selects single sweep-operation.

- ㉖ **RESET Button**—Arms the trigger circuit for a single sweep. Triggering requirements are the same as in NORM trigger mode. After the completion of a triggered sweep, pressing in the SGL SWP RESET button rearms the trigger circuitry to accept the next triggering event.

- ㉗ **Trigger SOURCE Switches**—Determine the source of the internal and external trigger signal for the trigger generator circuits.

CH 1—Trigger signal is obtained from the CH 1 OR X input connector.

VERT MODE—Trigger signals are automatically obtained alternately from the CH 1 OR X and CH 2 OR Y input signals in ALT vertical mode. In CHOP vertical mode, the trigger signal source is the sum of the Channel 1 and Channel 2 input signals.

CH 2—Trigger signal is obtained from the CH 2 OR Y input. The CH 2 INVERT switch also inverts the polarity of the internal Channel 2 trigger signal when the Channel 2 display is inverted.

EXT—Selects external trigger source. The actual form these triggers take is selected by the second SOURCE switch.

LINE—Routes a sample of the ac-power-line signal to the trigger circuit.

EXT/10—Divides the external signal applied to the EXT INPUT OR Z connector by a factor of ten before applying it to the trigger circuit.

EXT—Routes an external signal applied to the EXT INPUT OR Z connector to the trigger circuit.

EXT=Z—Routes the signal applied to the EXT INPUT OR Z connector to the Z-Axis amplifier rather than the trigger circuit.

- 28 **EXT INPUT OR Z Connector**—Provides for connection of external signals either to the trigger circuit for external triggering or to the Z-Axis amplifier for intensity modulation of the crt display.

REAR PANEL

Refer to Figure 2-3 for items 29 through 31.

- 29 **Fuse Holder**—Contains the ac-power-source fuse. See the rear-panel nomenclature for fuse rating and line-voltage range.

- 30 **Detachable-Power-Cord Receptacle**—Provides the connection point for the ac-power source to the instrument.
- 31 **Line Voltage Selector Switch**—Selects the line voltage operating range of either 115 Vac or 230 Vac.

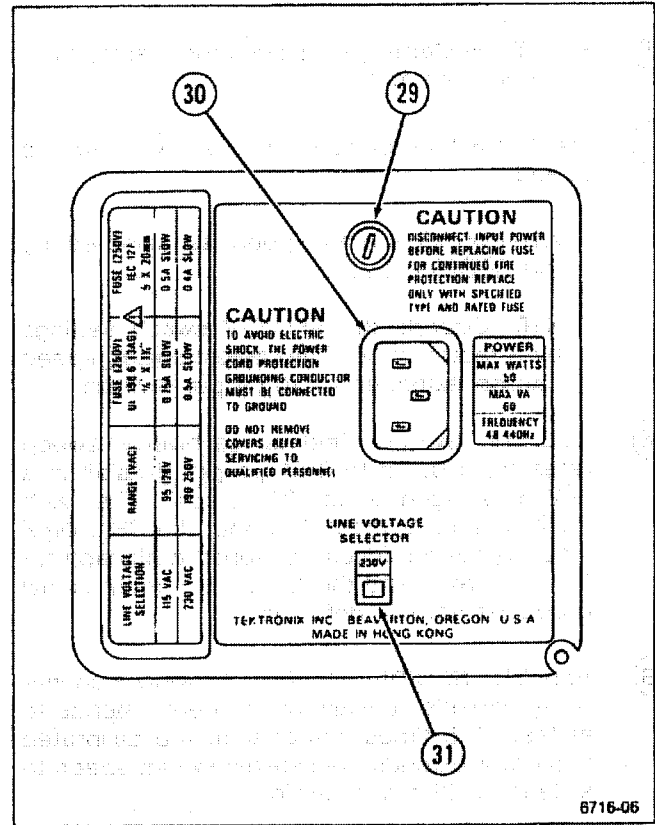

Figure 2-3. Rear Panel.

6716-06

OPERATING CONSIDERATIONS

This part contains basic operating information and techniques that should be considered before attempting to make any measurements with the instrument.

GRATICULE

The graticule is internally marked on the faceplate of the crt to eliminate parallax-viewing errors and to enable measurements (see Figure 2-4). The graticule is marked with eight vertical and ten horizontal major divisions. In addition, each major division is divided into five subdivisions. The vertical deflection factors and horizontal timing are calibrated to the graticule so that accurate measurements can be made directly from the crt. Also, percentage marks for the measurement of rise and fall times are located on the left side of the graticule.

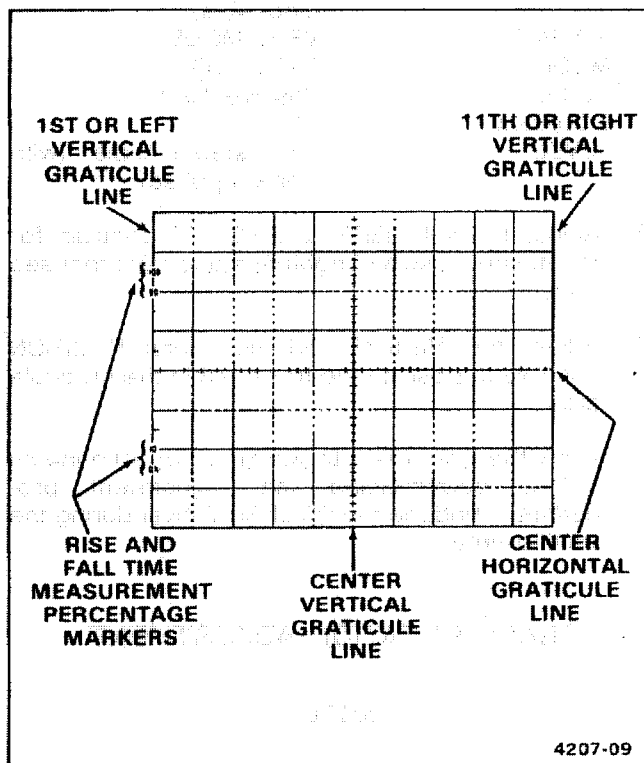

Figure 2-4. Graticule measurement markings.

CONNECTING SIGNALS

Signal Adapter

The signal adapter supplied with the instrument is usually the most convenient way to connect a signal to the 2205. These signal adapters are shielded to prevent pickup of electromagnetic interference. When connected to the 2205 input, a signal adapter presents 1 M Ω and about 100 pF impedance to the circuit under test. If this capacitance is disruptive to the circuit being tested, use the optional 10X probe.

Waveform Fidelity and Probe Grounds

When using a probe, its ground lead must be used for accurate measurements and observations. Use the shortest ground connection possible for best waveform fidelity.

In some cases, a separate ground from the unit under test to the ground receptacle on the oscilloscope front panel can reduce interference from low-frequency hum and noise. For rough checks of larger signals, such as 5 V logic, a ground lead separate from the probe - or even the safety ground connection, which is shared with the unit under test - may work for a signal ground. Fast signal transitions will be highly distorted, and extraneous noise will be induced without the probe ground connection, and/or with extra ground connections from the 2205 to the circuit being tested.

Probe Compensation (Optional 10X Probe)

Misadjustment of probe compensation is a common source of measurement error. Due to variations in oscilloscope input characteristics, probe compensation should be checked whenever a 10X probe is moved from one oscilloscope to another or from one channel to another on the same oscilloscope. Always compensate the probe to the channel on which it will be used. See the procedure in Section 4, *Checks and Adjustments*.

Probe Handling (Optional Probes)

Both the probe and the probe accessories should be handled carefully to prevent damage. Striking a hard surface can damage both the probe body and the probe tip. Exercise care to prevent the cable from being crushed, kinked, or excessively strained.

Coaxial Cables

To maintain good waveform fidelity and accuracy, use only high-quality, low-loss coaxial cables. When you use 50 Ω or 75 Ω coaxial cable, attach a matching external terminator. Some high frequency response will be lost without external termination.

OPERATOR'S CHECKS AND ADJUSTMENTS

To verify the operation and basic accuracy of your instrument before making measurements, perform the following checks and adjustment procedures. If adjustments are required beyond the scope of these operator's checks and adjustments, refer the instrument to qualified service personnel.

For new equipment checks, before proceeding with these instructions, refer to Preparation for Use in this manual to prepare the instrument for the initial start-up before applying power.

INITIAL SETUP

1. Verify that the POWER switch is OFF (switch is in the out position), and the Line Voltage Selector switch is set for the correct source voltage. Then plug the power cord into the ac power outlet.
2. Press in the POWER switch (ON) and set the instrument controls to obtain a baseline trace:

Display

INTENSITY	Midrange
FOCUS	Best defined display

Vertical (Both Channels)

POSITION (both)	Midrange
MODE	CH 1, NORM
VOLTS/DIV (both)	10 mV
AC-GND-DC (both)	DC
VOLTS/DIV Variable (both)	CAL (in detent)
Magnification (both)	X1 (CAL knobs in)

Horizontal

SEC/DIV	0.5 ms
SEC/DIV Variable	CAL (in detent)
POSITION	Midrange
MODE	X1

Trigger

HOLDOFF	MIN (fully counter-clockwise)
SOURCE MODE	VERT MODE
SLOPE	P-P AUTO
COUPLING	Positive (⌋)
LEVEL	AC
	For a stable display (with signal applied)

3. Adjust the INTENSITY and FOCUS controls for the desired display brightness and best focused trace.
4. Adjust the Vertical and Horizontal POSITION controls to position the trace within the graticule area.
5. Allow the instrument to warm up for 20 minutes before commencing the adjustment procedures. Reduce the INTENSITY level during the waiting time.

TRACE ROTATION ADJUSTMENT

NOTE

Normally, the trace will be parallel to the center horizontal graticule line, and TRACE ROTATION adjustment is not required.

1. Preset the instrument controls and obtain a baseline trace as described in Initial Setup.

2. Use the CH 1 POSITION control to move the baseline trace to the center horizontal graticule line.
3. If the baseline trace is not parallel to the center horizontal graticule line, use a small-bladed screwdriver or alignment tool to adjust the TRACE ROTATION control and align the trace with the graticule line.

PROBE COMPENSATION (Option 10X Probe)

Misadjustment of probe compensation is a source of measurement error. The attenuator probes are equipped with a compensation adjustment. To ensure optimum measurement accuracy, always check probe compensation before making measurements. Probe compensation is accomplished by the following steps:

1. Preset the instrument controls and obtain a baseline trace as described in the Initial Setup.
2. Connect the two 10X probes (supplied with the instrument) to the CH 1 OR X and CH 2 OR Y input connectors.
3. Connect the Channel 1 probe tip to the PROBE ADJUST terminal.
4. Use the CH 1 POSITION control to vertically center the display. If necessary, adjust the Trigger LEVEL control to obtain a stable display on the positive (↘) SLOPE.

NOTE

Refer to the instruction manual supplied with the probe for more complete information on the probe and probe compensation.

5. Check the waveform display for overshoot and rounding (see Figure 2-5); if necessary adjust the probe's compensation. Use a low-reactance alignment tool to adjust the LF comp capacitor for a square front corner on the waveform.
6. Disconnect the Channel 1 probe tip from the PROBE ADJUST terminal.
7. Connect the Channel 2 probe tip to the PROBE ADJUST terminal.
8. Set the Vertical MODE to CH 2.
9. Use the CH 2 POSITION control to vertically center the display.
10. Repeat step 5 for the Channel 2 probe.

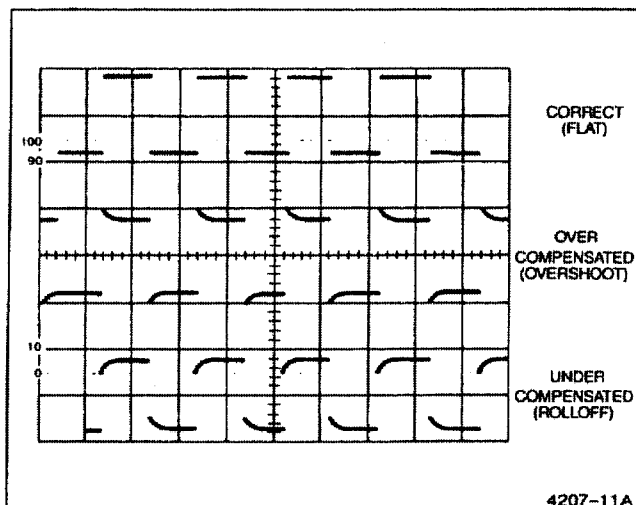

Figure 2-5. Probe compensation.

... ..

... ..

... ..

... ..

... ..

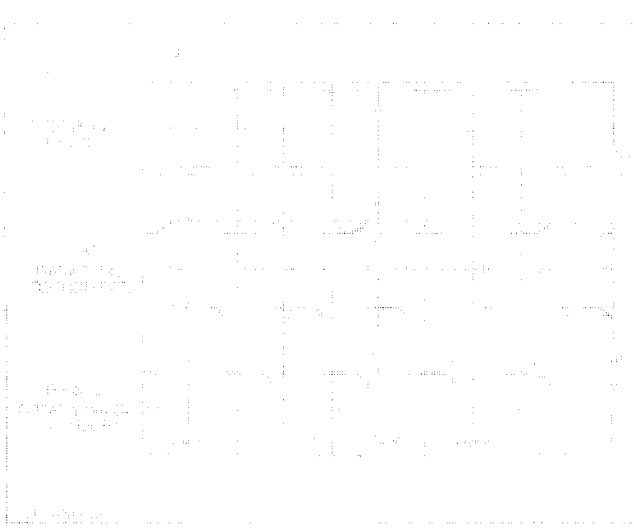

... ..

... ..

... ..

... ..

... ..

... ..

... ..

... ..

... ..

... ..

... ..

THEORY OF OPERATION

SECTION ORGANIZATION

This section of the manual contains a general summary of instrument functions followed by a detailed description of each major circuit. A basic block diagram, (Figure 9-4), and the schematic diagrams are located in the tabbed Diagrams section at the back of this manual. The block diagram and schematic diagrams are used to show the interconnections between parts of the circuitry and to indicate circuit components.

The schematic diagram number associated with each description is identified in the text and is shown on the block diagrams. For best understanding of the circuit being described, refer to the appropriate schematic diagram and the block diagram.

INTEGRATED CIRCUIT DESCRIPTIONS

Digital Logic Conventions

Digital logic circuits do many functions within the instrument. Functions and operation of the logic

circuits are represented by logic symbology and terminology. Most logic functions are described using the positive-logic convention. Positive logic is a system where the more positive of two levels is the TRUE (or 1) state; the more negative level is the FALSE (or 0) state. In this logic description, the TRUE state is HI, and the FALSE state is LO. Voltage levels for a HI or a LO state vary between specific devices. For detailed device characteristics, refer to the manufacturer's data book.

Linear Devices

The operation of individual linear integrated circuit devices in this section use waveforms or other techniques such as voltage measurement and simplified diagrams to illustrate their circuit operation.

GENERAL DESCRIPTION

In the following functional description of the 2205 Oscilloscope, refer to the block diagram (Figure 9-4) located in the Diagrams section of this manual. In Figure 9-4 the numbered diamond symbol in each major block refers to the appropriate schematic diagram number.

Vertical

Signals to be displayed on the crt (cathode-ray tube) are applied to either or both the CH 1 OR X and the CH 2 OR Y input connectors. The signals may be coupled to the attenuator either directly (DC) or through an input-coupling capacitor (AC). The inputs may also be disconnected, and the input to the attenuators grounded, by switching to the GND position of the input coupling switch. In the GND position, the ac-coupling capacitor is allowed to precharge to the dc level present at the input

connector. This precharging prevents large trace shifts of the display when switching from GND to AC coupling. The Attenuators are switched by the front-panel VOLTS/DIV switches and scale the applied signal level to obtain the desired display amplitude.

The output signals from the Attenuators are applied to the Vertical Preampifiers for amplification. The Channel 2 Preampifier has additional circuitry, permitting the operator to invert the Channel 2 display on the cathode-ray tube (crt). Trigger pickoffs in each channel supply a trigger signal to the Trigger Amplifier when internal triggering is selected.

Input signals are selected for display by the Channel Switching circuit under control of the front-panel VERTICAL MODE switches. The output signal from the Channel Switching circuit is applied to the Vertical Output Amplifier.

Final amplification of the vertical signal is done by the Vertical Output Amplifier. This stage produces the signal levels that vertically deflect the crt electron beam. For locating the position of off-screen displays, the dynamic range of the Amplifier can be limited with the Beam Find circuitry. This circuitry also intensifies the trace and limits horizontal deflection.

Triggering

The Trigger circuitry uses either the Internal Trigger signal obtained from the input signal(s), an External Trigger signal, or a Line Trigger signal derived from the ac power source to develop trigger signals for the Sweep Generator. The P-P Auto Trigger circuit sets the range of the Trigger Level to conform to within the peak-to-peak amplitude of the selected trigger signal when either P-P Auto or TV Field Trigger mode is selected. This allows triggering on most signals without needing to adjust the TRIGGER LEVEL control. In NORM mode, the TRIGGER LEVEL control must be adjusted to the signal level before a sweep will be triggered.

The triggering circuitry contains the TV Field Sync circuit. This circuit provides stable triggering on television vertical-sync pulses when in the TV Field triggering mode. TV Line triggering is possible using P-P AUTO trigger mode.

Sweep

The Sweep Logic circuit controls the sweep generation and Z-Axis unblanking for the Sweep display. When the TRIGGER Mode switches are set to either P-P AUTO or TV FIELD and no trigger signal is present, the Auto Baseline circuit causes the Sweep Logic circuit to produce a sweep for reference purposes. In the NORM setting, the Auto Baseline circuit is disabled and sweeps are not generated until a trigger event occurs. This is useful for triggering on low-repetition rate signals. The SGL SWP (single sweep) trigger mode allows only one sweep to be generated after being reset. Following the single sweep, the Trigger circuit is disabled until the SGL SWP RESET button is pressed again.

The Sweep Logic circuit controls the operation of the Miller Sweep Generator circuit. The Sweep circuit produces a linear sweep with a ramp time that is controlled by the SEC/DIV switch setting. The sweep signal is applied to the Horizontal Preamp for initial amplification and then to the Horizontal

Output Amplifier to drive the crt horizontal deflection plates.

Horizontal

The Horizontal Preamp gain is increased by a factor of 10 when the Horizontal MAG control is used. Horizontal positioning of the display is done in the Horizontal Preamp circuit.

In the X-Y mode of operation, the Channel 1 signal from the internal Trigger circuitry passes through the X-Y Amplifier to the Horizontal Preamp. In this operating mode, the Channel 1 Internal Trigger signal supplies the horizontal deflection to the crt, and the Miller Sweep circuit is disabled to inhibit sweep generation.

Z-Axis

The Z-Axis drive from the Sweep Logic circuit is applied to the Z-Axis Amplifier. The output signal from the Z-Axis Amplifier circuit sets the crt intensity. When using Chop Vertical mode, a blanking signal from the Chop Oscillator circuit blanks the crt display while switching between the vertical channels.

The DC Restorer circuit applies the output voltage of the Z-Axis Amplifier between the cathode and grid of the crt. High dc potentials on these elements prohibit direct coupling to the crt.

Power Supply

The Power Supply provides the necessary operating voltages for the instrument. Operating potentials are obtained from a circuit consisting of the Power Transformer, power supply control circuits, inverter, and inverter transformer. The inverter transformer secondary windings provide various ac-levels that are rectified and filtered to produce the operating voltages for the instrument.

Probe Adjust

A front-panel PROBE ADJUST output is provided for use in adjusting probe compensation. The voltage at the PROBE ADJUST connector is a negative-going square wave that has a peak-to-peak amplitude of about 500 mV with a repetition rate about 1 kHz.

DETAILED CIRCUIT DESCRIPTION

VERTICAL

Attenuators

The Channel 1 and Channel 2 Attenuator circuits, shown on Diagram 1, are identical except for the additional Invert circuitry in the Channel 2 Paraphase Amplifier. Therefore, only the Channel 1 Attenuator is described, with the Invert circuitry of Channel 2 discussed separately.

The Attenuator circuit (see Figure 3-1) provides control of the vertical deflection factor and the variable volts/division gain. Vertical input signals for display on the crt may be connected to either or both the CH 1 OR X and the CH 2 OR Y input connectors. In the X-Y mode of operation, the input signal applied to the CH 1 OR X connector provides horizontal (X-axis) deflection for the display, and the input signal applied to the CH 2 OR Y connector provides the vertical (Y-axis) deflection for the display.

Input Coupling (AC-GND-DC)

A signal from the CH 1 OR X input connector may be ac or dc coupled to the High-Impedance Attenuator circuit or disconnected completely by the Input Coupling Switch. Signals from the CH 1 OR X input connector are routed through resistor R1 to Input Coupling switch S101. When S101 is set for dc

coupling, the Channel 1 signal goes directly to the input of the High-Impedance Attenuator stage. When ac coupled, the ac portion of the input signal passes through the dc-blocking capacitor C2. The blocking capacitor stops the dc component of the input signal from reaching the Attenuator circuit. When switched into the signal path, attenuator AT1 attenuates the input signal by factors of 100, 10, 4, or 2. When S101 is set to GND, the direct signal path is opened and the input of the attenuator is connected to ground. This provides a ground reference without the need to remove the applied signal from the input connector. The coupling capacitor precharges through R2 and R4 to prevent large trace shifts when switching from GND to AC.

Input Attenuator

The effective deflection factor of each vertical channel is determined by the setting of the Channel VOLTS/DIV switch. The basic deflection factor of the Vertical system is 5 mV/DIV. For VOLT/DIV switch settings above 5 mV/DIV, frequency compensated voltage dividers (attenuators) are switched into the circuit. Each channel has $\div 2$, $\div 4$, $\div 10$ and $\div 100$ attenuators that are selected in various combinations to produce the different deflection factors. Each attenuator contains an adjustable series capacitor to provide correct attenuation at high frequencies, and an adjustable shunt capacitor to provide correct input capacitance.

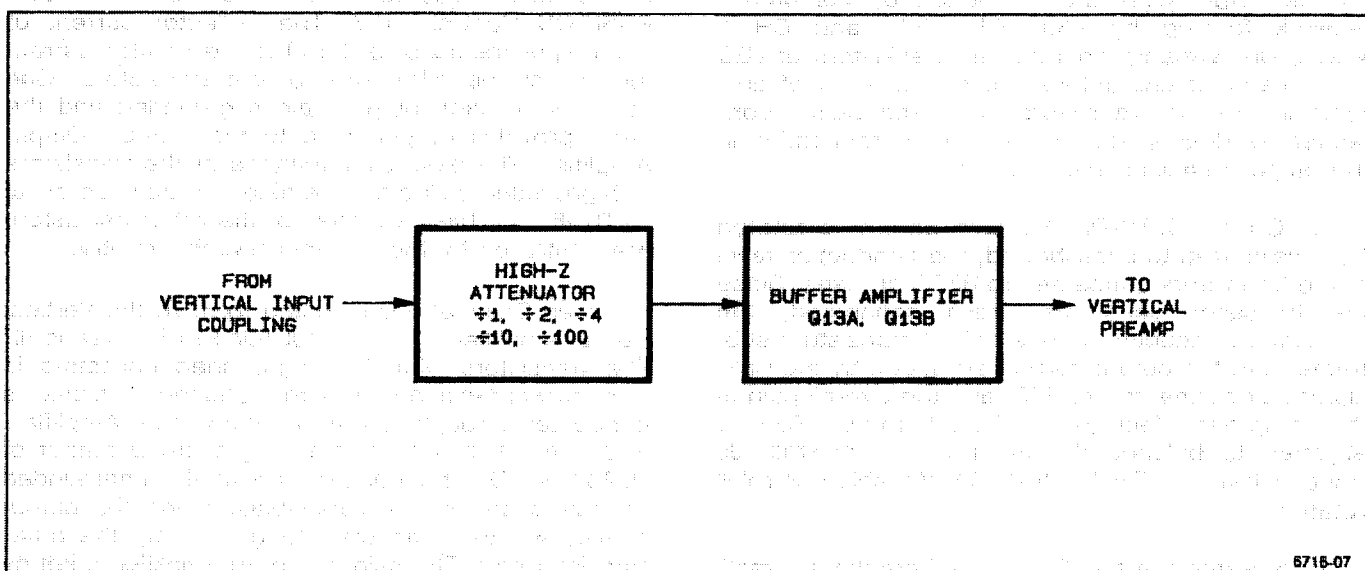

6715-07

Figure 3-1. Block diagram of the Channel 1 Attenuator.

Source Follower

The Channel 1 signal from the input attenuator is connected to the source follower Q13A via R6 and C6. Resistor R5 provides the input resistance. Resistor R6 provides input current limiting for Q13A and Q14. FET Q13B is a constant current source for Q13A. Transistors Q13A and Q13B provide a high output impedance for the attenuator stage and the input drive current needed for the Paraphase Amplifier U30 (first stage of amplification).

If excessively high amplitude signals are applied to the source follower Q13A, the signal current will be limited by R6 and Q14 (connected as diode) and the gate-source junction of Q13A. If an excessive negative going signal causes Q14 to become forward biased, Q13A gate is clamped to about -9.3V. An excessive positive going signal will forward bias the gate-source junction of Q13A. As soon as gate current flows, the gate voltage will stop increasing. Gate current is limited by the high resistance of R6.

Paraphase Amplifier

Paraphase Amplifier U30 converts the single-ended signal from Q13 into a differential signal for the Vertical Preamplifier. The signal from Q13A pin 5 goes to the base of one transistor in U30. The other input transistor in U30 is biased by the divider network formed by R30, R31, R32 and variable R33. Emitter current for the two input transistors is supplied by R22 and R23. Resistor R29 sets the gain for the stage. The collector current of the two input transistors serves as emitter current for the differential output transistor pairs. Base bias voltages for the output pairs are developed by the divider network formed by R39, R41, R42 and CH 1 VOLTS/DIV Variable control. The transistors of U30 have matched characteristics, so the ratio of currents in the two transistors U83B and U83C, connected as diodes, determines the current ratios in the output transistor pairs of U30.

As CH 1 VOLTS/DIV Variable control is rotated from calibrated to uncalibrated, the conduction level of the transistors connected to R35 increases. Since the transistor pairs are cross connected, the increased conduction in one pair of transistors subtracts from the output current produced by the transistor pair connected to R38, and the overall gain of the amplifier decreases. Potentiometer R33 is adjusted to balance the amplifier for minimal dc trace shift as the CH 1 VOLTS/DIV Variable control is rotated.

Incorporated in the Channel 2 Paraphase Amplifier is circuitry that allows the polarity of the Channel 2 signal to be inverted. When CH 2 INVERT

switch S90 is in NORM, the transistor pairs in U80 are biased as they are in U30, and CH 2 trace is not inverted. In CH 2 INVERT position, connections to the bases of the output transistor pairs are reversed, to produce an inverted Channel 2 trace. Potentiometer R83 is adjusted for minimal dc trace shift in CH 2 INVERT when rotating CH 2 VOLTS/DIV Variable control. Potentiometer R84 is switched in with R83 when in INVERT; it is adjusted for minimal dc trace shift when rotating CH 2 VOLTS/DIV Variable control.

Vertical Preamplifiers

The Channel 1 and Channel 2 Vertical Preamplifiers, shown on Diagram 2, are identical in operation. Operation of the Channel 1 amplifier is described. Differential signal current from the Paraphase Amplifier is amplified to produce drive current for the Vertical Output Amplifier. Internal trigger signals for the Trigger circuitry are picked off before the Vertical Preamplifier. The Channel Switch circuitry controls channel selection for the crt display.

Common-base transistors Q102 and Q103, which complete the Paraphase Amplifier portion of the circuitry shown on Diagram 1, convert differential current from the Paraphase Amplifier into level-shifted voltages that drive the bases of the input transistors of Vertical Preamplifier U130 and the Internal Trigger circuitry.

Emitter current for the input transistors of U130 is supplied by Q114 and Q115. The base bias of Q114 and Q115 is adjusted by the Channel 1 VERTICAL POSITION Control R123. The collector current of each input transistor of U130 is the emitter current for two of the differential output transistors. One collector of each output pair is grounded and the other provides output drive to the Vertical Output Amplifier. The base bias voltages of the transistors with grounded collectors are held at ground potential by R136. The base voltages of the other transistors are controlled by the Channel Switch circuitry.

When Channel 1 is selected to drive the Vertical Output Amplifier, the Q output (pin 9) of U540A is HI. The transistors with the ungrounded collectors is then forward-biased, and the Channel 1 signal is conducted through to the Vertical Output Amplifier. If Channel 1 is not selected, then the Q output of U540A is LO. The transistors with the ungrounded collectors are then reverse-biased and the output signals will be conducted to ground by the other transistor pair. The gain of the Preamplifier is set by adjusting R145 to control the signal current that is shunted between the two differential outputs.

Channel Switch Logic

The Channel Switch circuitry, shown on Diagram 2, uses the front-panel VERTICAL MODE switches to select the crt display format. See Figure 3-2 for a block diagram of the circuit.

When any display mode other than X-Y is selected, the XY line connected to S550 is at ground potential. VERTICAL MODE switches S545 and S550 control the connection between the XY control line and the SET(L) and RESET(L) inputs of flip-flop U540A to obtain the various display formats described below.

CHANNEL 1 DISPLAY ONLY. The CH 1 position of S550 grounds the SET input of U540A while the RESET input is held HI by pull-up resistor R539. This produces a HI and a LO on the Q and \bar{Q} outputs of U540A respectively, and the Channel 1 Preamplifier signal then drives the Vertical Output Amplifier (as described in the Vertical Preamplifier section). The Channel 2 Preamplifier will be disabled.

CHANNEL 2 DISPLAY ONLY. The CH 2 position of S550 holds the RESET input of U540A LO through CR538, and the SET input is held HI by pull-up

resistor R538. The outputs of U540A are then Q LO and \bar{Q} HI enabling the Channel 2 Preamplifier signal to drive the Vertical Output Amplifier, while the CH 1 Preamplifier is disabled.

To display the ADD, ALT, or CHOP formats, S550 must be in the BOTH position to ground the A, C, and F pins of S545.

ADD DISPLAY. In the ADD position of S545, both the SET and RESET inputs of U540A are held LO by CR534 and CR537. The Q and \bar{Q} outputs of U540A are then both HI, and signal currents from the Channel 1 and Channel 2 Preamplifiers add together to drive the Vertical Output Amplifier.

CHOP DISPLAY. In the CHOP position, the CHOP ENABLE line is held LO, keeping the inputs of U537D and U537C HI. This enables CHOP multivibrator U537D to begin switching. The switching rate is determined primarily by the component values of R544, R545, and C545. The output of U537C (the inverted output of the multivibrator circuit) supplies the CHOP clock to flip-flop U540A via U537A. The output of U537C also drives U537B, the CHOP Blanking Pulse Generator.

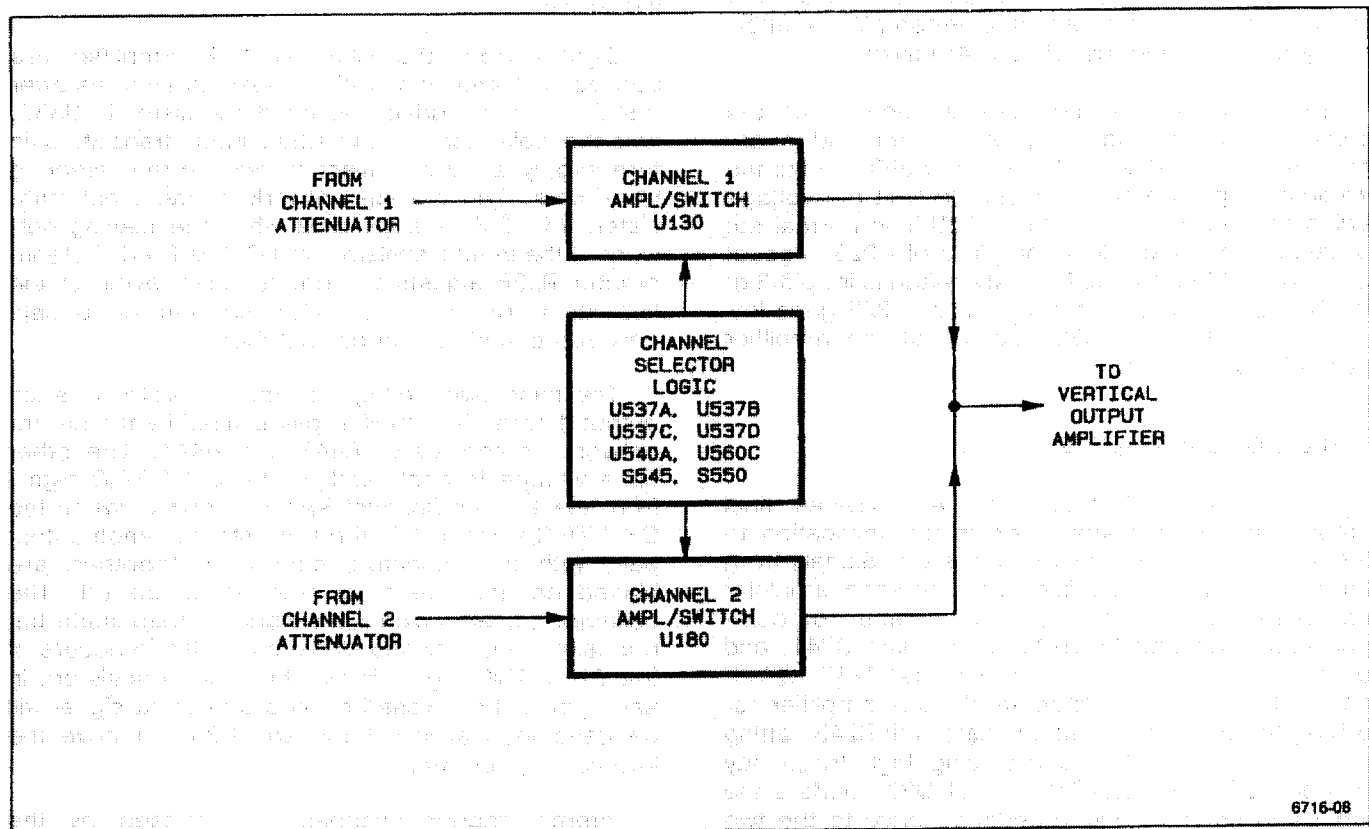

Figure 3-2. Block diagram of the Channel Switching.

Coupling capacitor C547 and resistors R547 and R548 form a differentiating circuit that produces positive-going and negative-going short duration pulses. These pulses are inverted by U537B to generate the Chop Blank signal to the Z-Axis Amplifier. The pulses blank the crt during CHOP switching times.

The Alt Sync signal applied to one input of U537A is HI except during Holdoff. This allows the output of U537C to be inverted by U537A which drives the clock input of U540A. Since the \bar{Q} output of U540A is connected back to the D input, and both the SET and RESET inputs are HI, the outputs of U540A toggle (change states) with each clock input. The Vertical Output Amplifier is then driven alternately from the Channel 1 and Channel 2 Preamplifiers at the CHOP rate.

ALTERNATE DISPLAY. In ALT, the CHOP ENABLE line is held HI, disabling CHOP multivibrator U537D. The output of U537C will be HI and the Chop Blank signal from U537B will be LO. Input signals to U537A are the HI from U537C and the ALT SYNC from the Holdoff circuitry in the Sweep Generator. The output of U537A will then be the inverted ALT SYNC signal that clocks Channel Select flip-flop U540A. This causes the outputs of U540A to toggle at the end of each sweep so that the Channel 1 and Channel 2 Preamplifiers alternately drive the Vertical Output Amplifier.

Beam Find keeps the vertical trace within the graticule area for locating off-screen and over-scanned traces. BEAM FIND switch S390 adjusts the Vertical Output Amplifier biasing to limit the voltage swing at the crt plates. When S390 is in normal out position, the voltage level on pin 3 of U225 is about zero volts. When the BEAM FIND switch is in, pin 3 of U225 goes to -8.6 V, the output of U225 goes low and bias Q202 and Q203 such that the amplifier dynamic range is limited.

Vertical Output Amplifier

The Vertical Output Amplifier provides final amplification of the input signals for application to the vertical deflection plates of the crt. Signals from the preamplifier are applied to a differential amplifier composed of Q230 and Q231 with frequency compensation provided by R241, R280, and C241, and overall gain set by R233. Transistors Q232, Q236, and Q237 form a cascade-feed-back amplifier for driving the positive deflection plate with R243 setting amplifier gain and C243 providing high frequency compensation. Emitter follower of Q232 buffers the input and provides low impedance drive to the two output transistors Q236 and Q237. For slow speed signals, Q236 serves as a current source for Q237,

and at high frequencies, the signal is coupled through C232 to the base of Q236. This provides additional pull-up output current to drive the crt at high frequencies. The amplifier consisting of Q234, Q238, and Q239 drives the negative deflection plate the same way the positive deflection plate is driven.

TRIGGER AMPLIFIERS AND SWITCHING

The Trigger Amplifiers shown on Diagram 3, provide signals to the Trigger Generator circuit from either the Vertical Preamplifiers, the EXT INPUT OR Z connector, or the power line. The SOURCE switch selects Channel 1, Channel 2, external, or line as the trigger source.

Internal Trigger

Signals from the Vertical Preamplifiers drive the internal Trigger Amplifier with channel selection determined by the VERTICAL switch.

Trigger pickoff from the Preamplifiers is accomplished by Q450 and Q451 for Channel 1, and Q452 and Q453 for Channel 2. The circuitry associated with Channel 2 is the same as that for Channel 1 except that it does not have a trigger offset adjustment.

Signals from the Channel 1 Preamplifier are applied to Q450 and Q451. These emitter-follower transistors each drive one input transistor in U335, and the collectors of the U335 input transistors in turn supply emitter current to two current-steering transistors. The biasing network of the input transistors of U335 is adjustable while the biasing network of the input transistors of U310 is fixed. Potentiometer R338 adjusts the emitter bias levels of the two input transistors of U335 so that dc offsets between channels can be matched.

The base bias voltage of one transistor in each output differential amplifier pair is fixed by the divider network composed of R443 and R444. The other base voltage is controlled by the CH 1 TRIG signal from the Trigger Channel Switch circuitry. When the CH 1 TRIG signal is LO, the transistors in each output pair, with the collectors connected together, are biased on and the other transistors are off. The collector signal currents are equal in magnitude but opposite in polarity and signal cancellation occurs. If the CH 1 TRIG signal is HI, the other transistors in each pair will be biased on and an output signal will be developed across R339 and R340 to drive the Internal Trigger Amplifier.

Internal trigger channels are chosen by the SOURCE switch S555. The CH 1, VERT MODE, and CH 2 positions of S555 forward biases CR348 and

CR349 to prevent external trigger signals or the line trigger signal from reaching the Trigger Generator. Signals from the Internal Trigger Amplifier are passed to the Trigger Generator through forward-biased CR450.

CHANNEL 1. For triggering from Channel 1, the SOURCE and VERTICAL MODE switches are set to CH 1. Input pin 9 of U300C will be LO, which places a LO at the output of U300C. This LO is passed through U304B to an input of U300B. The output of U300B goes HI enabling Channel 1 signal through U335. The Channel 2 signal path is disabled by the output of U300A being LO.

CHANNEL 2. For triggering from Channel 2, the SOURCE and VERTICAL MODE switches are set to CH 2. Input pin 8 of U300C will be LO, which places a LO at the output of U300C. This LO is passed through U304A to one of the inputs of U300A. The output of U300A goes HI enabling Channel 2 signal through U335. The Channel 1 signal path is disabled by the output of U300B being LO.

VERT MODE. When the SOURCE switch is set to VERT MODE, trigger source selection is determined by the two VERTICAL MODE switches. The outputs of U300A and U300B will be HI, and triggering selection will then be determined by the inputs of U304A and U304B that are controlled by U540A in the Channel Switch circuit.

When Channel 1 is selected (VERTICAL MODE switch set to CH 1), the input to U304B will be HI. The LO from the output of U304B is applied to U300B and causes the CH 1 TRIG line to go HI and enable the Channel 1 trigger signal. The input to U304A will be LO placing a HI at the input of U300A. The LO from the output of U300A causes the Channel 2 trigger signal to be disabled.

When Channel 2 is selected (VERTICAL MODE switch set to CH 2), the outputs of U304B, U300B, U304A, and U300A will be the reverse of the states described for Channel 1 selection. The Channel 2 signal will be selected and the Channel 1 trigger signal disabled.

When selecting ALT VERTICAL MODE, the inputs of U304A and U304B will toggle with each sweep. The outputs of the two gates will also toggle and the Trigger signal source will alternate with the displayed channel.

In the ADD VERTICAL MODE position, both inputs to U304A and U304B will be LO and both gate outputs of U300A and U300B will be HI. Both Channel 1 and Channel 2 signal paths will be enabled and their output current will be summed at the inputs of the

Internal Trigger Amplifier to produce the internal trigger signal.

In CHOP VERTICAL MODE position, the CHOP ENABLE line places a LO on both inputs of U300D. The output of U300D is held HI and applied to the inputs U304A and U304B and the signal to the Internal Trigger Amplifier will be the same as for the ADD mode.

Internal Trigger Amplifier

The Internal Trigger Amplifier converts the differential trigger signals from the Vertical Pre-amplifiers into a single-ended signal that drives the X-Axis Amplifier and the Trigger Generator.

Signal current is applied to the emitters of U380C and U380D. The collector current of U380C is converted to a voltage across feedback resistor R357. The opposite-phase collector current of U380A causes a voltage drop across R359 that adds to the voltage at the collector of U380D. This voltage appears at the base of U415C which buffers and level shifts the signal back to 0 V. The emitter signal of U415C drives the X-Axis Amplifier, and the base of Q410. The emitter signal of Q410 in turn drives the Trigger Generator whenever CR450 is forward biased.

External Trigger Amplifier

The External Trigger Amplifier buffers signals applied to the EXT INPUT OR Z connector and line-frequency trigger signals. The output of the amplifier is applied to the Trigger Generator.

EXT. When the SOURCE switches are set to EXT, and either EXT=Z, EXT, or EXT/10 is selected, the trigger source is the signal applied to the EXT INPUT OR Z connector. In EXT/10 position the input signal is attenuated by a factor of 10 through the compensated divider composed of R377, R378, C377, and C378.

The external signal is applied to the gate of Q370. FET Q371 supplies source current for Q370 such that there will be no voltage drop across the gate-source junction of Q370. FETS Q370 and Q371 are a matched pair. The source-follower Q370 drives emitter-follower transistor Q412 which lowers the Amplifier output impedance. Protection-diode CR381 clamps the signal at the gate of Q370 to about -9 V. The Amplifier output will drive the Trigger Generator through forward-biased CR451 whenever the SOURCE switch is set to EXT. When the SOURCE switch is not set to EXT, the base-emitter junction of Q370 will be reverse biased via Q411, CR452, CR348 or CR349, and the Amplifier will be disabled.

When the SOURCE switch is set to EXT=Z position, the external signal is buffered by Q370 and applied to the Z-Axis amplifier for intensity modulation.

The line trigger from the power supply is applied to Q370 when the SOURCE switches are set to EXT and LINE positions.

TRIGGER GENERATOR

The Trigger Generator, shown on Diagram 3, supplies trigger signals to the Sweep Generator. Included in the Trigger Generator circuit are the P-P Auto Trigger, Norm Trigger, and TV Triggering circuitry.

Trigger Level Circuit

The Trigger Level Circuit establishes voltages at the ends of the TRIGGER LEVEL potentiometer as a function of the TRIGGER Mode switch selection and trigger signals selected by the SOURCE switch. In the P-P Auto and TV Field mode, U415E is off and CR341 is reverse biased. Diode CR417 is forward biased turning U415A off. Trigger signals selected by the SOURCE switch are applied to peak detectors consisting of U415B-Q415 and U380E-Q465. These peak detectors track dc levels and have a high voltage transfer efficiency. The positive-peak and negative-peak signal levels stored by C418 and C431 are near the peak levels of the trigger signal. Amplifiers U425A and U425B are configured as voltage followers with transistors U415D and Q490 in the feedback loops. These transistors thermally compensate for U415B and Q465 and level shift the amplifier outputs back to the original dc levels of the input trigger signals. The output of U425B will be the positive peak voltage of the input trigger signal and the output of U425A will be the negative peak voltage. Potentiometers R445 and R446 adjust for dc offsets in the trigger circuitry.

In the Norm mode, +8.6 V is applied to the junction of R417 and R432, turning on U415E and forward biasing CR431. Diode CR417 is reverse biased turning U415A on. Input transistors U415B and Q465 are then biased off and no trigger signals will reach the Trigger Level circuit. The inputs and outputs of U425A and U425B will then be fixed voltages and independent of trigger-signal amplitude.

Trigger Level Comparator

The Trigger Level Comparator compares signals selected by the TRIGGER SOURCE switch to a voltage set by the TRIGGER LEVEL control. Positive or negative slope triggering is selected by the TRIGGER SLOPE switch.

Transistors U460B and U460E compare the wiper voltage on the TRIGGER LEVEL control to the input trigger signal, and the transistor with the higher base voltage will conduct more of the available emitter current. The output collector currents supply emitter current to two transistor pairs (U460A-U460F and U460C-U460D) which serve as cross-wired switches that are biased on or off by the TRIGGER SLOPE switch. When S460 is set to the positive slope position, U460A and U460D are biased on and U460C and U460F are biased off. For the negative slope position, the transistors reverse states to invert the comparator output polarity.

Schmitt Trigger and TV Trigger Circuit

This circuitry generates a signal that drives the Trigger Logic as a function of the Trigger Level Comparator output signal and the TRIGGER MODE switches.

The output signals from the Trigger Level Comparator drive Q400 and Q401. These transistors are configured as a current mirror that converts the differential output to a single-ended current to drive amplifier U480C. Potentiometer R481 corrects for dc offsets between positive and negative slope. Shunt-feedback amplifier U480C converts a current input to a voltage output to drive the input of the Schmitt Trigger, U480D, through R485. Positive feedback for the Schmitt Trigger is provided by potentiometer R489, and C489 reduces trigger jitter increasing positive feedback at higher frequencies. The setting of R489 determines the circuit hysteresis.

When TV FIELD is not selected, the $\overline{\text{TVF}}$ line is HI, and is buffered by Q487. Transistors Q488 and Q489 are biased off and a LO is placed on one input of U480A by R492-R493. This LO input will cause U480A to invert the output from U480D. With Q489 off, a LO will be placed on one input of U480B by R495 and U480B will also act as an inverter. The Trigger signal at the output of U480B is therefore the same as the input signal to U480A.

When TV FIELD is selected, the $\overline{\text{TVF}}$ line is LO, and is buffered by Q847. The outputs of U480D will determine the conduction states of Q488 and Q489, and the input of U480A connected to R492 will be HI. The output of U480A will be LO and U480B will invert signal at its other input. Signals at the collector of Q489 are filtered by C495, R495, and C496 to reject

TV video information and average the TV horizontal-sync pulses. Setting the trigger-level threshold near the center of the horizontal-sync-pulse swing establishes the untriggered level. When the TV vertical-sync-block occurs, the output of the filter applied to U480B pin 7 rises to a level that will cause U480B to switch. Precise TV field synchronization is obtained as a result of this filtering action. The Trigger signal output will be the inverse of the filtered signal appearing at U480B pin 7.

SWEEP GENERATOR AND LOGIC

The Sweep Generator and Logic circuitry, shown on Diagrams 4 and 5, produce a linear voltage ramp that drives the Horizontal Preamp. The Sweep Generator circuit also produces signals that are used to generate correct timing of the crt unblanking and intensity levels used for viewing the display. See Figure 3-3 for the block diagram of the Sweep Generator and Logic circuitry.

Miller Sweep Generator

The Miller Sweep Generator produces a linear voltage ramp that drives the Horizontal Amplifier. It produces the ramp voltage by maintaining a constant current through timing capacitors, causing a linear voltage rise across them as they charge.

Field-effect transistors Q704A and Q704B are matched devices with Q704B acting as the current source for Q704A. Since the gate and source of Q704B are connected together, the source current available to Q704A is just enough so that there is no voltage drop across the gate-source junction of Q704A.

When the sweep is not running, Q701 is biased on, holding the selected timing capacitors in a discharged state. The low impedance of Q701 in the feedback path holds the Miller Sweep output near ground potential. The voltage across Q701, in addition to the base-emitter voltage of Q706, prevents saturation of the output device.

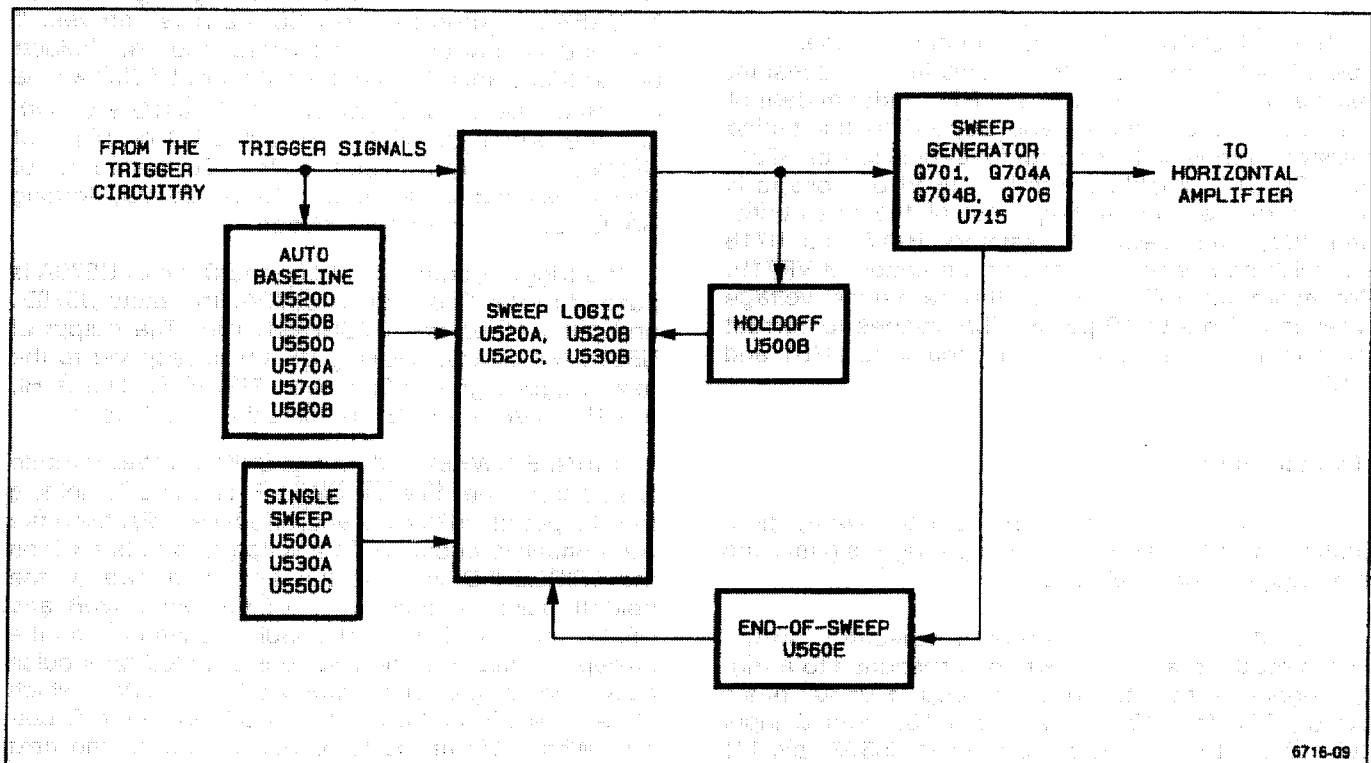

Figure 3-3. Block diagram of the Sweep Generator and Logic.

The sweep ramp starts when Q536 is biased off. The GATE signal going to the base of Q701 from the Sweep Logic circuit turns Q701 off. The timing capacitors then begin charging at a rate set by timing resistors R701, R702 and the position of the SEC/DIV switch S701. One end of timing resistor R701 is connected to the wiper of R721 and the other end is connected to the input of the Miller integrator. Due to feedback from the circuit output through the timing capacitors, the integrator input voltage at the gate of Q704A remains fixed and sets a constant voltage across the timing resistors. This constant voltage produces a constant charging current through the timing capacitors, which results in a linearly increasing voltage ramp at the output of the Miller Sweep circuit.

When the ramp reaches about 12 V, the Sweep Logic circuitry starts the holdoff period in which Q701 is turned on and the Sweep Generator is reset. This holdoff period is necessary so that the timing capacitors can be fully discharged before another sweep starts. Capacitors C704 and C703 are always in the charging circuit and are used for high sweep speeds. For medium sweep speeds, capacitors C701 and C702 are in series. For slow sweep speeds, only capacitor C701 is used.

The SEC/DIV Variable circuitry uses an operational amplifier to maintain a constant reference voltage at one end of R721 independent of the circuit load. The voltage applied to the timing resistors varies with the rotational position of R721, the SEC/DIV Variable control. A fixed dc voltage is applied to the noninverting input of the operational amplifier, and feedback resistors R717 and R718 establish double that voltage at the anode of VR719. Potentiometer R722 adjusts the reference voltage when in 0.5 ms to 10 μ s SEC/DIV ranges to correct for mismatch between timing capacitors C701 and C702.

Sweep Logic

The Sweep Logic circuitry controls sweep generation, as a function of incoming trigger signals and the Trigger mode selected.

NORM. When NORM trigger is selected, the circuit is ready to start the sweep in response to a trigger signal. At the start of the sweep, a U530B has a LO on SET (pin 12), RESET (pin 13), and D input (pin 10). A trigger pulse received at U530B (pin 11) will clock the LO on the D input to the Q output and enable the sweep to start. The output of the sweep generator is fed back via W701-4 into the potential divider R501 and R502. This divider is arranged so that when the ramp voltage reaches about 12 V, U560E is turned on, producing a LO on the input of

inverter U520A. The inverted signal of U520A is applied to the input of U520B. The signal from U520B is inverted by U520C to produce an OR function, then fed to the SET input (pin 12) of U530B. This overrides the CLOCK input of U530B and puts a HI on the Q output (pin 15), resetting the sweep. The sweep reset is also fed to the input (pin 12) of the monostable U500B, which gives a holdoff time dependent on the holdoff capacitor selected and the variable holdoff resistor chain. The holdoff pulse from the monostable maintains the HI on the SET input of U530B until the end of the holdoff period, then the SET is driven LO, allowing the next trigger pulse to start the sweep.

P-P AUTO. In the P-P AUTO mode, the sweep will free-run in the absence of a trigger signal. Should there be more than 50 ms between trigger pulses, the Auto Baseline circuitry consisting of U580B, U520D, U570A and U570B will start a sweep. U580B is a 20 Hz clock pulse generator. This signal is passed through Schmitt trigger U520D to provide a fast rise time. This is to ensure that both D inputs of U570A and U570B switch at the same time.

With no trigger signal, the first clock pulse from U580B resets U570A, putting a HI on D input of U570B. This will then be clocked (giving a LO on TRIGGERED) when the next 50 ms pulse arrives. If the end of sweep has occurred and the holdoff period has elapsed, then the output of U520C will be LO. Because TRIGGERED and P-P AUTO are both LO, the output of U550D will put a LO on pin 7 of U550B. As the other input is also LO, the output of U550B will put a HI on pin 13 of U530B, forcing GATE LO and starting a sweep.

If a trigger occurs, the HI on the D pin of U570A is passed to the Q output of U570A, to resets U570B, and put a HI on the TRIGGERED line. The output of U550B will be LO, allowing U530B to respond to the next trigger signal. When the TRIGGERED line is HI, the TRIG'D/READY LED is turned on via U550A.

SINGLE SWEEP. When the SINGLE SWEEP mode is selected, the SINGLE SWEEP line is LO, holding the D input of U570A LO and effectively disabling the Auto Baseline circuitry. This action also puts a LO on the TRIGGERED line. At the end of a sweep, the holdoff pulse is latched by U530A via U520B and U550C, and the D input of U530B is driven HI and the sweep is disabled. The sweep is enabled by a pulse from the single shot monostable U500A, which clocks the LO on the D input of U530A to the Q output. With a LO at the Q output of U530A, the next trigger signal will start a sweep. Switch debounce circuit U500A along with the timing components R506 and C506 will give a pulse width of about 30 ns, which is shorter than the fastest sweep speed. U500A also sets U510B turning on the TRIG'D/READY LED via U550A. When the holdoff period starts (and

U500A has timed out), U500B will clock a LO back onto the Q output of U540B, allowing the TRIG'D/READY LED to be extinguished.

X-Y. In the X-Y mode of operation, the \overline{XY} line is LO, holding the input of U520A LO through CR521. The output of U520A via U520B and U520C will hold U530B set and no sweep can be started.

HORIZONTAL

The Horizontal Amplifier circuit, shown on Diagram 5 provides the output signals that drive the horizontal crt deflection plates. Signals applied to the Horizontal Preamp can come from either the Miller Sweep Generator (for sweep deflection) or from the XY Amplifier (when X-Y display mode is selected). See Figure 3-4 for the block diagram of the Horizontal Amplifier.

The Horizontal Position control, X10 magnifier circuitry, and the horizontal portion of the Beam Find circuitry are also contained in the Horizontal Amplifier Circuit.

X-Y Amplifier

In the X-Y mode of operation, the \overline{XY} signal (buffered by Q736) is low, biasing Q732 in the linear region. Transistors Q732 and Q737 are a transconductance amplifier that changes an input voltage to output current. The input signal is applied through gain adjust R395. The X Offset adjustment is R736. The signal current flowing out of Q737 is fed into the shunt feedback stage. The sweep is held at a constant low output level when in X-Y mode.

When in sweep mode, the \overline{XY} line is high and biases Q732 off, that biases Q737 off and disables the XY amplifier. The \overline{XY} line also turns on U380B, thereby not allowing the X axis signal to get to the amplifier. The sweep signal is applied through R740 and the gain setting resistor (R744) to the Horizontal Preamp stage.

Horizontal Preamp

The Horizontal Preamp amplifies input signals for application to the Horizontal Output Amplifier.

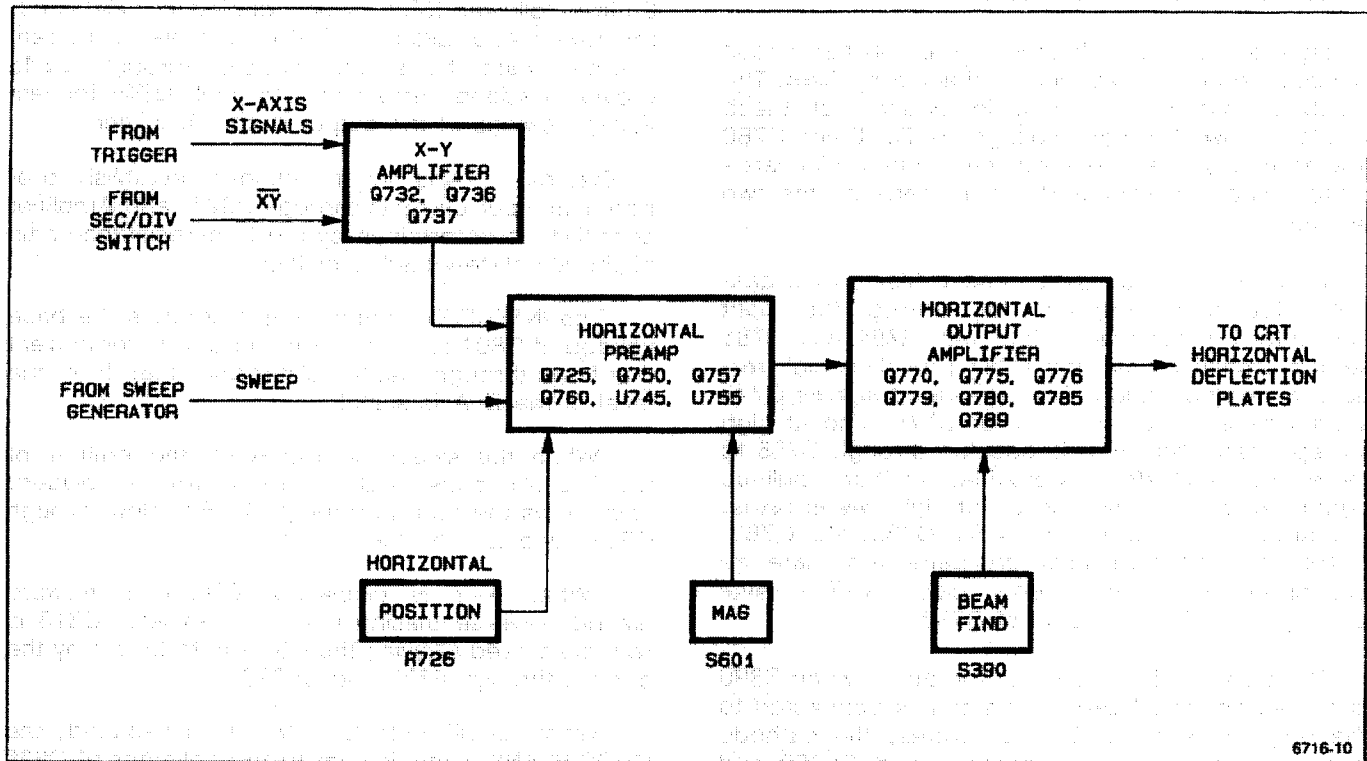

Figure 3-4. Block diagram of the Horizontal Amplifier.

6716-10

The preamplifier is a cascode differential pair. The gain is set by the network connected between pins 7 of U755C and 10 of U755D. With MAG switch S601 in X1, the X1 MAG line is high, Q760 and U745E are off, and the current sources consisting of U745A and U755A are on for normal operation with the gain set by R763. When MAG switch is X10, the X1 MAG signal is LO, Q760 and U745E saturate, and the current sources consisting of U755B and U745B are on. This forward biases CR773 and CR774, a low impedance is switched in, and the X10 timing adjustment is made using X10 Mag Gain R777. Magnifier registration is adjusted by R782 so that there is no horizontal trace shift when switching between the X10 and X1 positions. The X1 MAG line is held at a constant high when in X-Y mode.

The sweep signal, or the X-Axis signal (depending on mode of operation) with the horizontal position signal from R726, is buffered by Q750 and Q759 and applied pin 6 of U745C. Pin 9 of U745D is held to a fixed voltage level by Q725. The horizontal position signal adjusts the trace horizontally in both the sweep and X-Y modes.

Horizontal Output Amplifier

The Horizontal Output Amplifier provides final amplification of the horizontal signal to drive the horizontal crt deflection plates.

Signals from the Horizontal Preamplifier circuit are used to drive two shunt feedback amplifiers. The feedback makes the input impedance of these amplifiers low. The base voltages of Q770 and Q780 are at nearly the same dc level due to forward-biased diodes CR781 and CR791 between the two emitters.

Transistors Q770, Q775, and Q779 form a cascode feedback amplifier for driving the right horizontal crt deflection plate with R784 and R785 setting amplifier gain and C783 providing high frequency compensation. For low-speed signals Q779 serves as a current source for Q775, and at high sweep rates, the ramp is coupled through C785 to the emitter of Q779. This provides additional pull-up output current to drive the crt at high sweep rates. The amplifier, consisting of Q780, Q785, and Q789, drives the left horizontal crt deflection plate as described above with zener diode VR792 level shifting the collector signal of Q780.

The BEAM FIND function is turned on when S390 is closed and the Beam Find signal is connected to the negative supply. Q776 saturates, the cathode voltage of VR776 goes negative, and CR780 and CR890 become forward biased. Current through these diodes causes the output common-mode

voltage of the two shunt-feedback amplifiers to be shifted positively to reduce the available voltage swing at the crt plates. This prevents the trace from being deflected off-screen horizontally.

Z-AXIS AMPLIFIER

The Z-Axis Amplifier, shown on Diagram 7, controls the crt intensity level via several input-signal sources. The effect of these input signals is either to increase or decrease trace intensity or to completely blank portions of the display. The Z-Axis signal current, as determined by the Z-Axis switching logic and the input current from the EXT INPUT OR Z connector (if in use), are summed at the emitter of common-base amplifier Q825 and thereby sets the collector current of the stage. The common-base amplifier provides a low-impedance termination for the input signals and isolates the signal sources from the rest of the Z-Axis Amplifier.

Common-base transistor Q829 passes a constant current through R832. This current is divided between Q825 and Q829, with the portion through Q829 driving the shunt-feedback output amplifier formed by Q835, Q840, and Q845. The bias level of Q825 therefore controls the emitter current available to Q829. The shunt feedback-resistors of R841 and R843 sets the transresistance gain for changing the input current to a proportional output voltage. Emitter-follower Q835 is dc coupled to Q840 and, for low-speed signals, Q845 acts as a current source. Fast transitions couple through C845 providing added current gain through Q845 for fast voltage swings at the output of the Amplifier.

External Z-Axis input voltages establish proportional input currents through R823, and Amplifier sensitivity is determined by the transresistance gain of the shunt-feedback amplifier.

The INTENSITY potentiometer controls the base voltage of Q804 to set the amount of emitter current that flows through that transistor and, therefore, the level of the Z-Axis signal.

When the sweep is displayed, the emitter of Q817 is LO, causing CR817 to be reverse biased. This allows the current through R818 to flow through CR818 and turn on the Z-Axis.

When X-Y is displayed, CR817 is forward biased, reverse biasing CR818. Transistor Q818 is reverse biased allowing the intensity to be set by the current through R820 and CR820.

When CHOP VERTICAL MODE is selected, the CHOP BLANK signal is sent to the collector of Q825 through CR824 during the display-switching time. Diode CR825 is reverse biased and the forward bias

of Q829 rises to the blanking level. When blanked, the output of the Z-Axis Amplifier drops to reduce the crt beam current below viewing intensity.

When the BEAM FIND button is pressed, the BEAM FIND line goes to about -8V sinking about 1 mA from the Z-Axis Amplifier, over-riding any other current combinations, and therefore un-blanking the trace.

DC Restorer

The DC Restorer circuit sets the crt control-grid bias and couples the ac and dc components of the Z-Axis Amplifier output to the crt control grid. Direct coupling of the Z-Axis Amplifier output to the crt control grid is not employed because of the high potential differences involved. Refer to Figure 3-5 during the following discussion.

Ac drive to the DC Restorer circuit is obtained from pin 3 of T902. The drive voltage has an ac peak amplitude of about 100V, at a frequency of about 20 kHz and is coupled into the DC Restorer circuit through C853 and R853. The cathode of CR851 is biased by the wiper voltage of Grid Bias potentiometer R851, and the ac drive voltage is clamped whenever the positive peaks reach a level that forward biases CR851.

The Z-Axis Amplifier output voltage, which varies between +10 V and +75 V, is applied to the DC Restorer at the anode of CR853. The ac drive voltage holds CR853 reverse biased until the voltage falls below the Z-Axis Amplifier output voltage level. At that point, CR853 becomes forward biased and clamps the junction of CR851, CR853, and R854 to the Z-Axis output level. Thus, the ac-drive voltage is clamped at two levels to produce a square-wave signal with a positive dc-offset level.

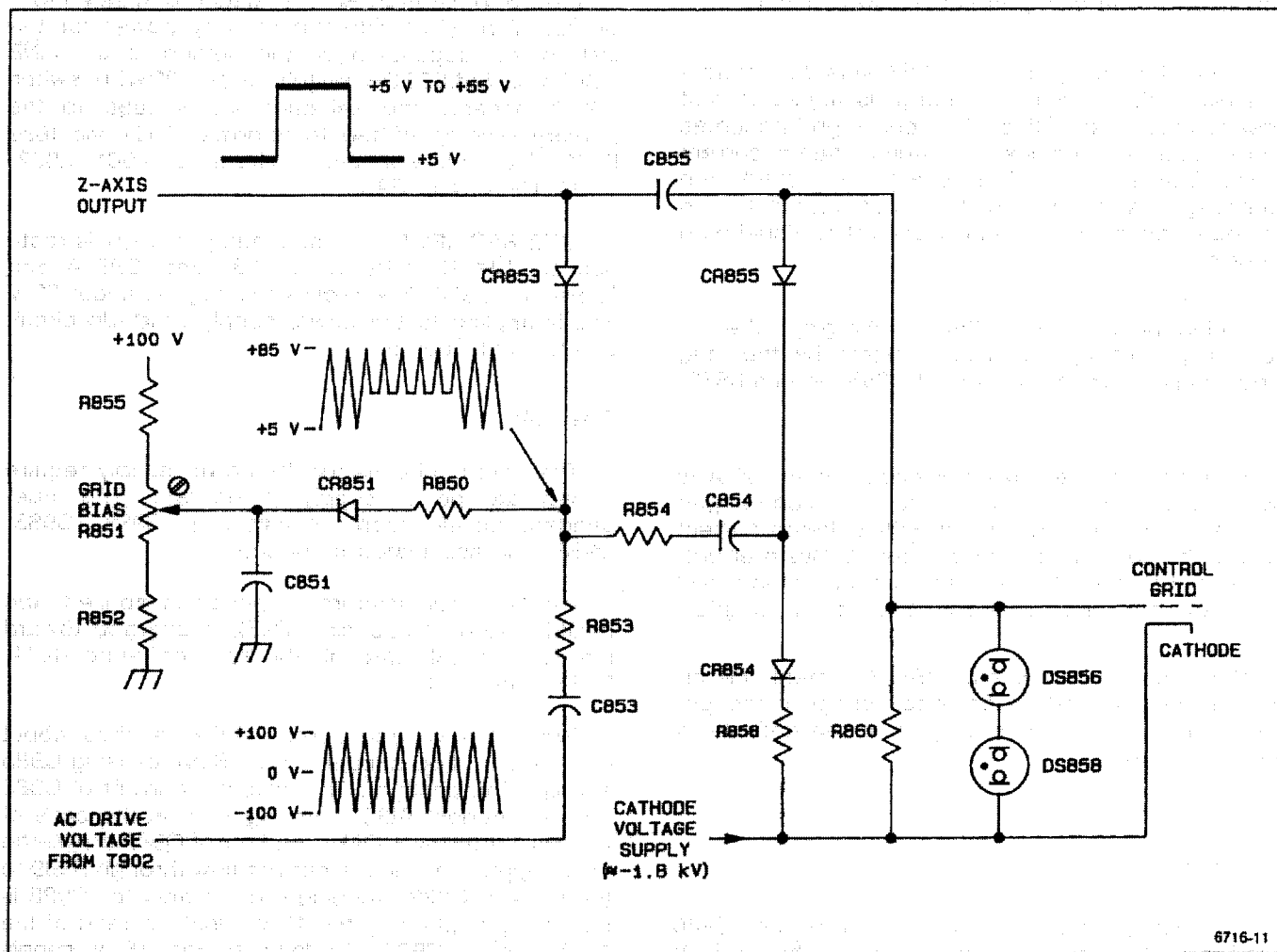

Figure 3-5. Simplified diagram of the Dc Restorer.

6716-11

The DC Restorer is referenced to the -1.8 kV crt cathode voltage through R858 and CR854. Initially, both C855 and C854 charge up to a level determined by the difference between the Z-Axis output voltage and the crt cathode voltage. Capacitor C855 charges from the Z-Axis output through R858, CR854, and CR855, to the crt cathode. Capacitor C854 charges through R858, CR854, R854, and CR853 to the crt cathode.

During the positive transitions of the ac drive, from the lower clamped level toward the higher clamped level, the charge on C854 increases. The voltage increase across C854 is equal to the amplitude of the positive transition. The negative transition is coupled through C854 to reverse bias CR854 and to forward bias CR855. The increased charge of C854 is then transferred to C855 as C854 discharges toward the Z-Axis output level. Successive cycles of the ac input to the DC Restorer charge C855 to a voltage equal to the initial level plus the amplitude of the clamped square-wave input.

The added charge held by C855 sets the control-grid bias voltage. If more charge is added to that already present on C855, the control grid becomes more negative, and less crt writing-beam current flows. Conversely, if less charge is added, the control-grid voltage level becomes closer to the cathode-voltage level, and more crt writing-beam current flows.

During periods that C854 is charging, the crt control-grid voltage is held constant by the long time-constant discharge path of C855 through R860.

Fast-rise and fast-fall transitions of the Z-Axis output signal are coupled to the crt control grid through C855 to start the crt writing-beam current toward the new intensity level. The DC Restorer output level then follows the Z-Axis output-voltage level to set the new bias voltage for the crt control grid.

Neon lamps DS858 and DS856 protect the crt from excessive grid-to-cathode voltage if the potential on either the control grid or the cathode is lost for any reason.

CRT Supply

The voltage doubler of CR975, CR976, and C980 produces -1.8 kV for the crt cathode. The -1.8 kV supply is filtered by a low-pass filter formed by R976, R978, C976, and C979.

Focus Circuit

Focus voltage is developed from the -1.8 kV supply by a voltage divider formed by R894 and R892 and FOCUS potentiometer R893.

POWER SUPPLY AND PROBE ADJUST

The Power Supply circuitry converts the ac power line voltage into the voltages needed for instrument operation. It consists of Ac Power Input, Start-Up, Current Control, Regulator, and Inverter circuits on the primary side of the high frequency power transformer. The secondary side of the high frequency power transformer provides the necessary supply voltages for the instrument. See Figure 3-6 for the block diagram of the Power Supply.

Ac Power Input

LINE SWITCHING. Ac line voltage of either 115 V or 230 V may provide the primary power for the instrument, depending on the setting of the LINE VOLTAGE SELECTOR switch S902. POWER switch S901 connects the selected line voltage to the primary winding of the transformer T901 via fuse F901. The ac line voltage is filtered by L901, L902, C903, C904, and C905.

LINE RECTIFIER. The secondary of T901 is rectified by CR901, CR902, CR903, and CR904 and filtered by C900. The rectified voltage is about 60 V and is applied to the power supply Start-Up circuit and Current Source.

Start-UP

The control circuits for the power supply require a separate power supply to operate. The independent power supply consists of Q982, Q985, Q988, and associated components.

Initially, when instrument power is applied, the positive plate of capacitor C982 is charged toward the 60 V supply through the resistor string R984, R983, and R970.

When the voltage across C982 reaches about 45 V, a 3 V drop occurs across R987 causing Q985 and Q988 to conduct. The collector current of Q985 passes through VR982, placing 16 V at the base of the emitter follower Q982. Emitter of Q982 drives the 15 V supply. This allows current flow through R989 to the base of Q988, keeping it on. Transistor Q988 is now being kept on by the 15 V supply instead of the 45 V across C982. As long as the 15 V supply remains above the 12 volt level, the positive feedback through R989 will keep Q988 saturated.

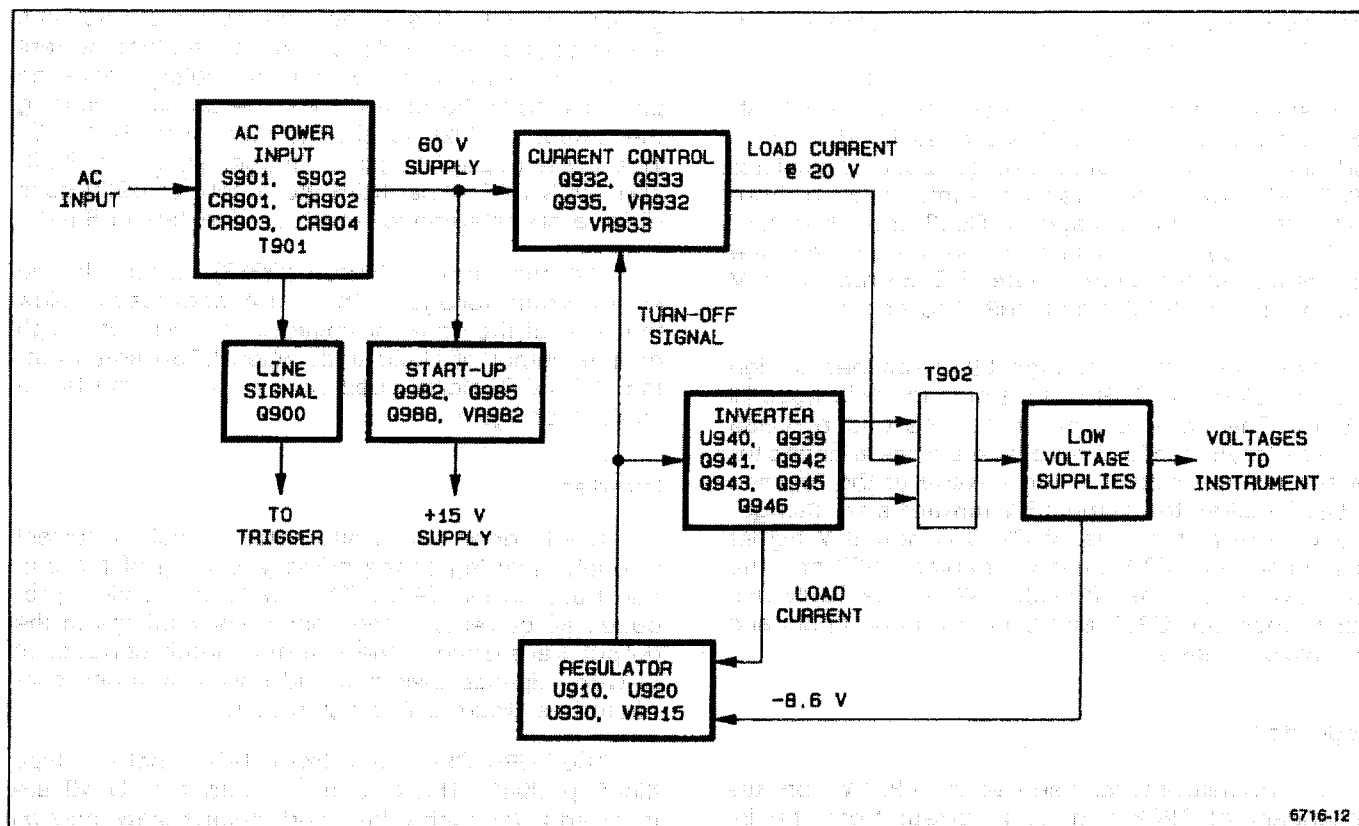

Figure 3-6. Block diagram of the Power Supply.

After the initial startup, current passed by Q982 is applied through CR980 via R971 and R980 instead of C982. If there is not enough current to C982, the 15 V supply will drop below the 12 V level turning off Q982, Q985 and Q988.

Current Source and Current Switching

The Current Source and Current Switching circuits provides a regulated dc current that produces 20 V for the high frequency power transformer T902 from the 60 V supply.

CURRENT SOURCE. The Current Source circuit is made up of power MOSFET Q933, inductor L950 and associated components. This circuit provides a triangle-shaped current pulse on top of the dc current (about 1.5 A) to transformer T902. The peak amplitude of the triangle-shaped current pulse is determined by the load requirements. The rise time varies with the voltage level of the 60 V (45 V to 75 V); the fall time is fixed at 8 μ s.

A triangle current signal is developed across L950 by the switching of Q933. With MOSFET Q933 turned on, the 60 V supply from the line rectifier is

applied to one end of L950 via Q933. The other end of L950 is held to 20 V by the capacitive load that is reflected through the high frequency power transformer T902. With a 40 V difference across L950, the current in the inductor increases (rising portion of the triangle-shaped current pulse) until Q933 is turned off by the Current Switch circuit. With Q933 turned off, the stored current in L950 will continue to flow to the center tap of T902. The current decreases with the falling portion of the triangle current pulse. Diode CR950 becomes forward biased clamping Q933 drain to ground. This puts 20 V across L950, opposing the current flow. When Q933 turns on, CR950 becomes reversed biased and 60 V supply is applied to L950 again.

CURRENT SWITCHING. The Current Switching circuit applies the TURN OFF signal from the Regulator circuit to the Current Source circuit. The TURN OFF signal controls the load current through L950. The circuit consist of Q935, Q932, and associated components.

When the power is first turned on, C933 is uncharged and the emitter voltage of Q935 is LO (0 V). Capacitor C933 quickly charges toward the 60 V supply through VR932 and VR933. When C933 is

charged to the 60 V supply, the source-gate voltage of Q933 is 0 V, turning it off.

Eventually, the 15 V supply comes up. The TURN OFF signal at the base of Q935 goes LO due to insufficient current passing through L950. Transistor Q932 will now start draining some charge from C933, reducing the voltage on C933 enough to turn on Q933. C933 continues to discharge until the voltage across the source-gate of Q933 reaches 9 V causing zeners VR932 and VR933 to conduct.

When the current through L950 reaches a high enough value, the TURN OFF signal to Q935 goes HI (15 V). The 15 V is applied to one end of C933 through Q935. Since the voltage across a capacitor cannot change instantly, the voltage at the top end of C933 makes the same 15 V upward step change. The voltage at the gate of Q933 is now 6 V higher than its source (60 V supply), turning Q933 off. The 15 V level also turns off Q932. When the TURN OFF signal goes LO, Q932 and Q933 turns on again and the cycle repeats.

Regulator

The Regulator Circuit senses the -8.6 V from the secondary of T902 and load current from the inverter circuit to develop a TURN OFF signal for the Current Control and Inverter circuits.

The -8.6 V from the secondary is applied to one end of R916 -8.6 V potentiometer. The potentiometer R916 sets the reference voltage for U910B. The dc error voltage from U910B is filtered for any ac components by capacitor C925. Zener VR925 clamps the dc error voltage to 3 V and limits the amount of load current from the Current Source to about 3 amps. The dc error voltage is applied to pin 2 of Comparator U920.

The dc error voltage is proportional to the power requirements of the load. For instance, an increase in the load will lower the -8.6 V increasing the amplitude of the dc error voltage. An increase in the amplitude of the dc error voltage means that more current is needed to maintain the -8.6 V level.

Load current from Inverter circuitry is converted to a voltage level by R910 and applied to pin 3 of U910A. The voltage amplification of U910A is 1 V per ampere of load current. This voltage level represents the instantaneous value of load current.

The voltage level on pin 3 of U920 is compared to the dc error voltage on pin 2 of U920. As long as the voltage level on pin 3 remains below the dc error voltage on pin 2, the output of U920 will be high. The high from U920 will not trigger the monostable pulse

generator U930. This will hold the output of U930 in a low state and keep Q933 turned on. The load current will continue to increase until the voltage level on pin 3 exceeds the dc error voltage on pin 2 causing the output of U920 to change state from HI to LO. This LO is applied to pin 2 (trigger input) of U930. The TURN OFF signal from the output of U930 goes HI for a predetermined length of time (about 8 μ s).

With the Current Source (Q933) turned off, the load current voltage from U910A decreases below the level of the dc error voltage. This will put a high on the output of U920 and, when U930 times out, the TURN OFF signal goes back to LO and starts the cycle over again.

Inverter

The Inverter circuit alternately switches current through each leg of the primary winding of the output transformer T902. This switching action produces ac currents in the secondary windings of the output transformer. The inverter circuit consists of D-type, flip-flop switches and power switches connected as discrete Darlington pairs.

The TURN OFF signal from U930 clocks D-type flip-flop U940. The Q and \bar{Q} output of U940 are inverted from each other, and change state only on the leading edge of the clock signal. Although the on time of the pulse generator is not identical to the off time, the period of the on time plus the off time is the same from one cycle to the next. The output switching of U940 will produce a square wave with a 50% duty cycle to the inverter switches.

The two outputs of U940 are applied to the drivers Q939 and Q943. The drivers turn the power switches (Q941 and Q942) (Q945 and Q946) on and off alternately to produce an ac voltage in the secondary winding of the output transformer.

When Q output of U940 goes HI, power switch Q939 conducts and pulls the collector and one end of R941 to 0 V. The base of Q941 and Q942 goes to -2 V causing the emitter-base to become reverse biased turning the inverter switch off. When Q output goes LO, Q939 turns off and inverter switch emitter to base becomes forward biased, turning it on. The output of \bar{Q} performs in the same way as Q output for the other leg of the primary winding of the output transformer.

Low-Voltage Supplies

The secondary windings of T902 provides various ac voltages for rectification. The 200 V supply uses a voltage doubler consisting of CR983, CR984, C985, and C983. The 100 V is rectified by CR985 and filtered by C984. The diode bridge consisting of

CR986, CR987, CR988, and CR989 produces the 8.6 V and -8.6 V. Filtering of the 8.6 V is done by C986, C987 and L986; filtering of the -8.6 V is done by C988, C989 and L988. The 5.2 V supply is produced by CR990 and CR991 and filtered by C990, C991, and L990.

CRT Supply

The 900 V from the high-voltage winding of T902 is doubled by C980, CR975, and CR976 to produce -1.8 kV for the crt cathode. The -1.8 kV supply is filtered by a low-pass filter formed by R976, R978, C976, and C979. Neon lamps DS853 and DS856 protect against excessive voltage between the crt cathode and crt grid by conducting if the difference exceeds about 180 V.

Focus Circuit

Focus voltage is also developed from the -1.8 kV supply by a voltage divider formed by R892, R894, FOCUS potentiometer R893, R888, R889, R890, and R891.

Line Signal

Transistor Q900 is a floating differential amplifier with a dc bias network comprising R905, R904 and R902. Resistors R906 and R903 apply a small line frequency signal from the secondary of T901 to the base-emitter junction of Q900. The resultant collector current of Q900 is a line-frequency sine-wave that is applied to the trigger circuit.

Probe Adjust

The Probe Adjust circuitry, shown on Diagram 4, is a square-wave generator and diode switching network that produces a negative-going square-wave signal at PROBE ADJUST connector J590. Amplifier U580a forms a multivibrator that has an oscillation period set by the time constant of R587 and C587. When the output of the multivibrator is at the positive supply voltage, CR588 is forward biased. This reverse biases CR589, and the PROBE ADJUST connector signal is held at ground potential by R590. When the multivibrator output switches states and goes to the negative supply voltage level, CR588 is reverse biased. Diode CR589 becomes forward biased, and the circuit output level drops to about -0.5V.

...the ... of ...

...the ... of ...

...the ... of ...

...the ... of ...

...the ... of ...

PERFORMANCE CHECK PROCEDURE

INTRODUCTION

PURPOSE

The Performance Check Procedure is used to verify the instrument's Performance Requirements statements listed in Table 1-1 and to determine the need for calibration. The performance checks may also be used as an acceptance test or as a preliminary troubleshooting aid.

PERFORMANCE CHECK INTERVAL

To ensure instrument accuracy, check its performance after every 2000 hours of operation, or once each year if used infrequently. A more frequent interval may be necessary if the instrument is subjected to harsh environments or severe usage.

STRUCTURE

The Performance Check Procedure is structured in subsections to permit checking individual sections of the instrument whenever a complete Performance Check is not required. At the beginning of each subsection there is an equipment-required list showing only the test equipment necessary for performing the steps in that subsection. In this list, the item number that follows each piece of equipment corresponds to the item number listed in Table 4-1.

Also at the beginning of each subsection is a list of all the front-panel control settings required to prepare the instrument for performing Step 1 in that subsection. Each succeeding step within a particular subsection should then be performed, both in the sequence presented and in its entirety, to ensure that control-setting changes will be correct for ensuing steps.

TEST EQUIPMENT REQUIRED

The test equipment listed in Table 4-1 is a complete list of the equipment required to accomplish both the Performance Check Procedure in this

section and the Adjustment Procedure in Section 5. Test equipment specifications described in Table 4-1 are the minimum necessary to provide accurate results. Therefore, equipment used must meet or exceed the listed specifications. Detailed operating instructions for test equipment are not given in this procedure. If more operating information is required, refer to the appropriate test equipment instruction manual.

When equipment other than that recommended is used, control settings of the test setup may need to be altered. If the exact item of equipment given as an example in Table 4-1 is not available, check the Minimum Specification column to determine if any other available test equipment might suffice to perform the check or adjustment.

LIMITS AND TOLERANCES

The limits and tolerances given in this procedure are valid for an instrument that is operating in and has been previously calibrated in an ambient temperature between +20°C and +30°C. The instrument also must have had at least a 20-minute warm-up period. Refer to Table 1-1 for tolerances applicable to an instrument that is operating outside this temperature range. All tolerances specified are for the instrument only and do not include test-equipment error.

PREPARATION FOR CHECKS

It is not necessary to remove the instrument cover to accomplish any subsection in the Performance Check Procedure, since all checks are made using operator-accessible front- and rear-panel controls and connectors.

The most accurate display checks are made with a stable, well-focused, low-intensity display. Unless otherwise noted, adjust the INTENSITY, FOCUS, and Trigger LEVEL controls as needed to view the display.

Table 4-1
Test Equipment Required

Item and Description	Minimum Specification	Purpose	Example of Suitable Test Equipment
1. Calibration Generator	Standard-amplitude signal levels: 5 mV to 50 V. Accuracy: $\pm 0.3\%$. High-amplitude signal levels: 1 V to 60 V. Repetition rate: 1 kHz. Fast-rise signal level: 1 V. Repetition rate: 1 MHz. Rise time: 1 ns or less. Flatness: $\pm 0.5\%$.	Signal source for gain and transient responses.	TEKTRONIX PG 506 Calibration Generator. ^a
2. Leveled Sine-Wave Generator	Frequency: 250 kHz to above 100 MHz. Output amplitude: variable from 10 mV to 5 V p-p. Output impedance: 50 Ω . Reference frequency: 50 kHz. Amplitude accuracy: constant within 3% of reference frequency as output frequency changes.	Vertical, horizontal, and triggering checks and adjustments. Display adjustments and Z-Axis check.	TEKTRONIX SG 503 Leveled Sine-Wave Generator. ^a
3. Time-Mark Generator	Marker outputs: 10 ns to 0.5 s. Marker accuracy: $\pm 0.1\%$. Trigger output: 1 ms to 0.1 μ s, time-coincident with markers.	Horizontal checks and adjustments. Display adjustment.	TEKTRONIX TG 501 Time-Mark Generator. ^a
4. Test Oscilloscope with 10X Probes	Bandwidth: dc to 50 MHz. Minimum deflection factor: 5 mV/div. Accuracy: $\pm 3\%$.	General troubleshooting, holdoff check.	TEKTRONIX 2225 Oscilloscope.
5. Digital Voltmeter (DMM)	Range: 0 to 250 V. Dc voltage accuracy: $\pm 0.15\%$, 4-1/2 digit display.	Power supply checks and adjustments. Vertical adjustment.	TEKTRONIX DM 501A Digital Multimeter. ^a
6. Coaxial Cable (2 required)	Impedance: 50 Ω . Length: 42 in. Connectors: BNC.	Signal interconnection.	Tektronix Part Number 012-0057-01.
7. Dual Input Coupler	Connectors: BNC female-to-dual-BNC male.	Signal interconnection.	Tektronix Part Number 067-0525-01.
8. Termination	Impedance: 50 Ω . Connectors: BNC.	Signal termination.	Tektronix Part Number 011-0049-01.
9. 10X Attenuator	Ratio: 10X. Impedance: 50 Ω . Connectors: BNC.	Vertical compensation and triggering checks.	Tektronix Part Number 011-0059-02.
10. Adapter	Connectors: Miniature probe tip to BNC adapter.	Signal interconnection.	Tektronix Part Number 013-0084-02.
11. Alignment Tool	Length: 1-in. shaft. Bit size: 3/32 in. Low Capacitance: insulated.	Adjust variable capacitors.	Tektronix Part Number 003-0675-00.
12. 10X Probe	Bandwidth: 50 MHz. Length: 2 m.	Probe Adjust check.	Tektronix P6103

^a Requires a TM 500-Series Power Module.

INDEX TO PERFORMANCE CHECK STEPS

Vertical

Page

- 1. Check Deflection Accuracy and Variable Range 4-4
- 2. Check Bandwidth 4-4
- 3. Check Channel Isolation 4-5
- 4. Check Common-Mode Rejection Ratio 4-5

Horizontal

- 1. Check Timing Accuracy and Linearity 4-6
- 2. Check Position Range 4-7

- 3. Check Variable Range 4-7
- 4. Check X Gain 4-7
- 5. Check X Bandwidth 4-7

Trigger

- 1. Check Internal Triggering 4-9
- 2. Check External Triggering 4-10
- 3. Check External Trigger Ranges 4-10
- 4. Check Single Sweep Operation 4-10

External Z-Axis and Probe Adjust

- 1. Check External Z-Axis Operation 4-12
- 2. Check Probe Adjust Operation 4-12

VERTICAL

Equipment Required (See Table 4-1):

- | | |
|--------------------------------------|-----------------------------|
| Calibration Generator (Item 1) | Dual-Input Coupler (Item 7) |
| Leveled Sine-Wave Generator (Item 2) | 50-Ω Termination (Item 8) |
| 50-Ω Coaxial Cable (Item 6) | |

INITIAL CONTROL SETTINGS

Vertical

- | | |
|---------------------------|------------|
| POSITION (both) | Midrange |
| MODE | CH 1, NORM |
| VOLTS/DIV (both) | 5 mV |
| VOLTS/DIV Variable (both) | CAL detent |
| AC-GND-DC | DC |

Horizontal

- | | |
|------------------|------------|
| POSITION | Midrange |
| MAG | X1 |
| SEC/DIV | 0.5 ms |
| SEC/DIV Variable | CAL detent |

Trigger

- | | |
|--------|--------------|
| SLOPE | Positive (⌋) |
| LEVEL | Midrange |
| MODE | P-P AUTO |
| SOURCE | VERT MODE |

PROCEDURE STEPS

1. Check Deflection Accuracy and Variable Range

a. Connect a 20-mV standard-amplitude signal from the calibration generator via a 50-Ω coaxial cable to the CH 1 OR X input connector.

b. CHECK—Deflection accuracy is within the limits given in Table 4-2 for each CH 1 VOLTS/DIV switch setting and corresponding standard-amplitude signal. When at the 20-mV VOLTS/DIV switch setting, rotate the CH 1 VOLTS/DIV Variable control fully counterclockwise and check that the display decreases to 2 divisions or less. Then return

the CH 1 VOLTS/DIV Variable control to the CAL detent and continue with the 50-mV check.

c. Move the cable from the CH 1 OR X input connector to the CH 2 OR Y input connector. Set the Vertical MODE switch to CH 2.

d. Repeat part b using the Channel 2 controls.

e. Disconnect the test equipment from the instrument.

2. Check Bandwidth

- a. Set:
- | | |
|------------------|-------|
| VOLTS/DIV (both) | 5 mV |
| SEC/DIV | 10 ms |

**Table 4-2
Deflection Accuracy Limits**

VOLTS/DIV Switch Setting	STANDARD Amplitude Signal	ACCURACY Limits (Divisions)
5 mV	20 mV	3.88 to 4.12
10 mV	50 mV	4.85 to 5.15
20 mV	0.1 V	4.85 to 5.15
50 mV	0.2 V	3.88 to 4.12
0.1 V	0.5 V	4.85 to 5.15
0.2 V	1 V	4.85 to 5.15
0.5 V	2 V	3.88 to 4.12
1 V	5 V	4.85 to 5.15
2 V	10 V	4.85 to 5.15
5 V	20 V	3.88 to 4.12

b. Connect the leveled sine-wave generator output via a 50-Ω coaxial cable and a 50-Ω termination to the CH 2 OR Y input connector.

c. Set the generator to produce a 50-kHz, 6-division display.

d. Increase the signal frequency until a 4.2-division display is obtained.

e. CHECK—The frequency is greater than 20 MHz.

f. Repeat parts c through e for all VOLTS/DIV settings from 10 mV to 5 V, up to the output-voltage upper limit of the sine-wave generator being used.

g. Move the cable from the CH 2 OR Y input connector to the CH 1 OR X input connector. Set the Vertical MODE switch to CH 1.

h. Repeat parts c through e for all indicated CH 1 VOLTS/DIV switch settings, up to the output-voltage upper limit of the sine-wave generator being used.

3. Check Channel Isolation

a. Set:

CH 1 VOLTS/DIV	1 V
CH 2 VOLTS/DIV	0.5 V
Channel 2 AC-GND-DC	GND
SEC/DIV	0.05 ms

b. Set the generator to produce a 20-MHz, 5-division display.

c. Set CH 1 VOLTS/DIV switch to 0.5 V for a 10-division display.

d. Set Vertical MODE switch to CH 2 and ALT.

e. CHECK—The display amplitude is less than 0.1 division.

f. Move the test-signal cable from the CH 1 OR X input connector to the CH 2 OR Y input connector.

g. Set:

Vertical MODE	CH 1
Channel 1 AC-GND-DC	GND
Channel 2 AC-GND-DC	DC

h. CHECK—The display amplitude is less than 0.1 division.

i. Disconnect the test equipment from the instrument.

4. Check Common Mode-Rejection Ratio

a. Set:

VOLTS/DIV (both)	10 mV
Channel 1 AC-GND-DC (both)	DC
Vertical MODE	BOTH, NORM, and ALT

b. Connect the leveled sine-wave generator output via a 50-Ω coaxial cable, a 50-Ω termination, and dual-input coupler to the CH1 OR X and CH 2 OR Y input connectors.

c. Set the generator to produce a 10-MHz, 6-division display.

d. Set Vertical MODE switch to CH 2 INVERT and ADD.

e. CHECK—Display amplitude is 0.6 division or less.

f. Disconnect the test equipment from the instrument.

HORIZONTAL

Equipment Required (See Table 4-1):

Calibration Generator (Item 1)	50-Ω Coaxial Cable (Item 6)
Leveled Sine-Wave Generator (Item 2)	50-Ω Termination (Item 8)
Time-Mark Generator (Item 3)	

INITIAL CONTROL SETTINGS

Vertical

POSITION (both)	Midrange
MODE	CH 1
VOLTS/DIV (both)	0.5 V
VOLTS/DIV Variable (both)	CAL detent
AC-GND-DC (both)	DC

Horizontal

POSITION	Midrange
MAG	X1
SEC/DIV	0.05 ms
SEC/DIV Variable	CAL detent

Trigger

SLOPE	Positive (↗)
LEVEL	Midrange
MODE	P-P AUTO
SOURCE	CH 1

d. CHECK—Timing accuracy is within 3% (0.24 division at the tenth vertical graticule line), and linearity is within 5% (0.10 division over any 2 of the center 8 divisions).

NOTE

For checking the timing accuracy of the SEC/DIV switch settings from 50 ms to 0.5 s, watch the time marker tips only at the second and tenth vertical graticule lines while adjusting the Horizontal POSITION controls to line up the time markers.

e. Repeat parts b through d for the remaining SEC/DIV and time-mark generator setting combinations shown in Table 4-3 under "X1 Normal" column.

f. Set:

SEC/DIV	0.1 μs
Horizontal MAG	X10

g. Select 20-ns time markers from the time-mark generator.

NOTE

The 20-ns time-markers tips are rounded off and cannot be used as measurement reference points. Use the rising edge of the time markers as measurement reference points. Vertically adjust the 50% point of the time markers on the center horizontal graticule line.

h. Use the Horizontal POSITION controls to align the first time marker that is 50 ns beyond the start of the sweep with the second vertical graticule line.

PROCEDURE STEPS

1. Check Timing Accuracy and Linearity

a. Connect 50-ns time markers from the time-mark generator via a 50-Ω coaxial cable and a 50-Ω termination to the CH 1 OR X input connector.

b. Adjust the Trigger LEVEL control for a stable, triggered display.

c. Use the Horizontal POSITION control to align the second time marker with the second vertical graticule line.

i. CHECK—Timing accuracy is within 4% (0.32 division at the tenth vertical graticule line), and linearity is within 7% (0.14 division over any 2 of the center 8 divisions). Exclude any portion of the sweep past the 50th magnified division.

j. Repeat parts h and i for the remaining SEC/DIV and time-mark generator setting combinations shown in Table 4-3 under the "X10 Magnified" column.

Table 4-3

Settings for Timing Accuracy Checks

SEC/DIV Switch Setting	Time-Mark Generator Setting	
	X1 Normal	X10 Magnified
0.1 μ s	0.1 μ s	20 ns
0.2 μ s	0.2 μ s	20 ns
0.5 μ s	0.5 μ s	50 ns
1 μ s	1 μ s	0.1 μ s
2 μ s	2 μ s	0.2 μ s
5 μ s	5 μ s	0.5 μ s
10 μ s	10 μ s	1 μ s
20 μ s	20 μ s	2 μ s
50 μ s	50 μ s	5 μ s
0.1 ms	0.1 ms	10 μ s
0.2 ms	0.2 ms	20 μ s
0.5 ms	0.5 ms	50 μ s
1 ms	1 ms	0.1 ms
2 ms	2 ms	0.2 ms
5 ms	5 ms	0.5 ms
10 ms	10 ms	1 ms
20 ms	20 ms	2 ms
50 ms	50 ms	5 ms
0.1 s	0.1 s	10 ms
0.2 s	0.2 s	20 ms
0.5 s	0.5 s	50 ms

2. Check POSITION Range

a. Set:

SEC DIV 0.1 ms
Horizontal MAG X1

b. Select 0.1 ms time markers from the time-mark generator.

c. CHECK—The start of the sweep can be positioned to the right of the center vertical graticule line by rotating the Horizontal POSITION control fully clockwise.

d. CHECK—The tenth time marker can be positioned to the left of the center vertical graticule line by rotating the Horizontal POSITION control fully counterclockwise.

e. Select 0.5 ms time markers from the time-mark generator.

f. Align the 3rd time marker with the center vertical graticule line using the Horizontal POSITION control.

g. Set the Horizontal MAG switch to X10.

h. CHECK—Magnified time marker can be positioned to the left of the center vertical graticule line by rotating the Horizontal POSITION control fully counterclockwise.

i. CHECK—Start of the sweep can be positioned to the right of the center vertical graticule line by rotating the Horizontal POSITION control fully clockwise.

3. Check Variable Range

a. Set the Horizontal MAG switch to X1 and center the display.

b. Set the SEC/DIV Variable control fully counterclockwise.

c. CHECK—The spacing between time markers is 2 divisions or less.

d. Return the SEC/DIV Variable knob to the CAL detent position.

e. Disconnect the test equipment from the instrument.

4. Check X Gain

a. Set:

VOLTS/DIV (both) 10 mV
SEC/DIV X-Y

b. Connect a 50-mV, standard-amplitude signal from the calibration generator via a 50- Ω coaxial cable to the CH 1 OR X input connector.

c. CHECK—The display is between 4.85 and 5.15 divisions.

d. Disconnect the test equipment from the instrument.

5. Check X Bandwidth

a. Set both channels VOLTS/DIV switches to 50 mV.

b. Connect the leveled sine-wave generator output via a 50-Ω coaxial cable and a 50-Ω termination to the CH 1 OR X input connector.

c. Set the generator to produce an 8-division horizontal display at an output frequency of 50 kHz.

d. Increase the output frequency until the X-Axis (horizontal) deflection amplitude is 5.7 divisions.

e. CHECK—The frequency is 2 MHz or greater.

f. Disconnect the test equipment from the instrument.

TRIGGER

Equipment Required (See Table 4-1):

Leveled Sine-Wave Generator (Item 2)
50- Ω Coaxial Cable (Item 6)

Dual-Input Coupler (Item 7)
50- Ω Termination (Item 8)

INITIAL CONTROL SETTINGS

Vertical

POSITION (both)	Midrange
MODE	CH 1, NORM
CH 1 VOLTS/DIV	0.1 V
CH 2 VOLTS/DIV	1 V
VOLTS/DIV Variable (both)	CAL detent
AC-GND-DC (both)	DC

Horizontal

POSITION (COARSE and FINE)	Midrange
MAG	X1
SEC/DIV	0.2 ms
SEC/DIV Variable	CAL detent

Trigger

SLOPE	Positive (\nearrow)
LEVEL	Midrange
MODE	P-P AUTO
SOURCE	VERT MODE

PROCEDURE STEPS

1. Check Internal Triggering

a. Connect the leveled sine-wave generator output via a 50- Ω coaxial cable and a 50- Ω termination to the CH 1 OR X input connector.

b. Set the generator to produce a 3-division display at an output frequency of 5 MHz.

c. Set channel 1 VOLTS/DIV switch to 1 V.

d. CHECK—Stable display can be obtained by adjusting the Trigger LEVEL control for each switch

combination given in Table 4-4. Ensure that the TRIG'D light comes on when triggered.

Table 4-4
Switch Combinations for Triggering Checks

Trigger MODE	Trigger SLOPE
NORM	Positive \nearrow
NORM	Negative \searrow
P-P AUTO	Negative \searrow
P-P AUTO	Positive \nearrow

e. Move the test-signal cable from the CH 1 OR X input connector to the CH 2 OR Y input connector. Set the Vertical MODE switch to CH 2.

f. Repeat part d.

g. Set:

SEC/DIV	0.01 ms
Horizontal MAG	X10

h. Set the generator output to produce a 30-MHz, 1-division display.

i. Repeat part d.

j. Move the test-signal cable from the CH 2 OR Y input connector to the CH 1 OR X input connector. Set the Vertical MODE switch to CH 1.

k. Repeat part d.

l. Disconnect the test equipment from the instrument.

2. Check External Triggering

a. Set:

CH 1 VOLTS/DIV	20 mV
SEC/DIV	0.2 ms
Horizontal MODE	X1
Trigger MODE	P-P AUTO
Trigger SOURCE	EXT, EXT

b. Connect the leveled sine-wave generator output via a 50-Ω coaxial cable, a 50-Ω termination, and a dual-input coupler to the CH 1 OR X input connector and EXT INPUT OR Z input connectors.

c. Set the generator to produce a 4-division (80 mV) horizontal display at an output frequency of 5 MHz.

d. CHECK—Stable display can be obtained by adjusting the Trigger LEVEL control for each switch combination given in Table 4-4.

e. Set:

CH 1 VOLT/DIV	50 mV
SEC/DIV	0.05 ms
Horizontal MODE	MAG

f. Set the generator to produce a 3-division (150 mV) horizontal display at an output frequency of 30 MHz.

g. Repeat part d.

h. Disconnect the test equipment from the instrument.

3. Check External Trigger Range

a. Set:

CH 1 VOLTS/DIV	0.5 V
SEC/DIV	20 ms
Trigger SLOPE	Positive (↗)

b. Set the leveled sine-wave generator to produce a 50-kHz, 6.4-division display.

c. Position the waveform equally about the center horizontal graticule line.

d. Set:

Trigger MODE	NORM
Trigger SOURCE	EXT, EXT

e. CHECK—Display is triggered along the entire positive slope of the waveform as the Trigger LEVEL control is rotated.

f. CHECK—Display is not triggered at either extreme of rotation of the Trigger LEVEL control.

g. Set the Trigger SLOPE switch to negative (↘).

h. CHECK—Display is triggered along the entire negative slope of the waveform as the Trigger LEVEL control is rotated.

i. CHECK—Display is not triggered at either extreme of rotation of the Trigger LEVEL control.

j. Disconnect the test equipment from the instrument.

4. Check Single Sweep Operation

a. Set:

CH 1 VOLTS/DIV	10 mV
SEC/DIV	0.5 ms
Trigger SOURCE	CH 1
Trigger SLOPE	Positive (↗)

b. Connect 50-mV, standard-amplitude signal from the calibration generator via a 50-Ω coaxial cable to the CH 1 OR X input connector.

c. Adjust the Trigger LEVEL control to obtain a stable display.

d. Set:

Channel 1 AC-GND-DC	GND
Trigger MODE	SGL SWP

e. Press the SGL SWP RESET button. The TRIG'D/READY LED illuminates and remains on.

f. Set the Channel 1 AC-GND-DC switch to DC.

NOTE

The INTENSITY control may require adjustment to observe the single-sweep trace.

g. CHECK-TRIG'D/READY LED goes out and a single sweep occurs.

h. Press the SGL SWP RESET button several times.

i. CHECK—A single-sweep trace occurs, and the TRIG'D/READY LED illuminates briefly every time the SGL SWP RESET button is pressed.

j. Disconnect the test equipment from the instrument.

EXTERNAL Z-AXIS AND PROBE ADJUST

Equipment Required (See Table 4-1):

Calibration Generator (Item 2)	50-Ω Termination (Item 8)
Two 50-Ω Coaxial Cable (Item 6)	10X Probe (Item 12)
Dual-Input Coupler (Item 7)	

INITIAL CONTROL SETTINGS

NOTE

Vertical

CH 1 POSITION	Midrange
MODE	CH 1, NORM
CH 1 VOLTS/DIV	1 V
CH 1 VOLTS/DIV Variable	CAL detent
Channel 1 AC-GND-DC	DC

The INTENSITY level may need adjustment to view the intensity modulation on the displayed waveform.

b. CHECK—For noticeable intensity modulation. The positive part of the sine wave should be of lower intensity than the negative part.

Horizontal

POSITION	Midrange
MAG	X1
SEC/DIV	20 ms
SEC/DIV Variable	CAL detent

c. Disconnect the test equipment from the instrument.

2. Check Probe Adjust Operation

Trigger

SLOPE	Positive (↗)
LEVEL	Midrange
MODE	P-P AUTO
SOURCE	EXT, EXT=Z

a. Set:

CH 1 VOLTS/DIV	10 mV
SEC/DIV	0.5 ms
Trigger SOURCE	CH 1

b. Connect the 10X Probe to the CH 1 OR X input connector and clip the probe tip to the PROBE connector on the instrument front panel. If necessary, adjust the probe compensation for a flat-topped square-wave display.

c. CHECK—Display amplitude is 4.75 to 5.25 divisions.

d. Disconnect the probe from the instrument.

PROCEDURE STEPS

1. Check External Z-Axis Operation

a. Connect a 5-V standard-amplitude signal from the calibration generator via dual-input coupler to the CH 1 OR X and EXT INPUT OR Z connectors.

ADJUSTMENT PROCEDURE

INTRODUCTION

PURPOSE

The Adjustment Procedure is used to return the instrument to conformance with the Performance Requirement statements listed in Table 1-1. Adjustments contained in this procedure should only be performed after checks from the Performance Check Procedure (Section 4) have indicated a need for readjustment or after repairs have been made to the instrument.

STRUCTURE

This procedure is structured into subsections, each of which can be performed independently to permit adjustment of individual sections of the instrument. For example, if only the Vertical section fails to meet the Performance Requirements or has been repaired, it can be readjusted with little or no effect on other sections of the instrument.

The Power Supply section, however, affects all other sections of the instrument. Therefore, if repairs or readjustments have been made that change the absolute value of any of the supply voltages, the entire Adjustment Procedure should be performed.

At the beginning of each subsection is a list of all the front-panel control settings required to prepare the instrument for performing Step 1 in that subsection. Each succeeding step within a subsection should be performed in sequence and in its entirety to ensure that control settings will be correct for ensuing steps. All steps within a subsection should be completed.

TEST EQUIPMENT REQUIRED

Table 4-1 is a complete list of the test equipment required to accomplish both the Performance Check Procedure in Section 4 and the Adjustment Procedure in this section. To assure accurate measurements, it is important that test equipment used for making these checks meet or exceed the specifications described in Table 4-1. When considering

use of equipment other than that recommended, utilize the Minimum Specification column to determine whether available test equipment will suffice.

Detailed operating instructions for test equipment are not given in this procedure. If more operating information is required, refer to the appropriate test equipment instruction manual.

LIMITS AND TOLERANCES

The limits and tolerances stated in this procedure are instrument specifications only if they are listed in the Performance Requirements column of Table 1-1. Tolerances given are applicable only to the instrument undergoing adjustment and do not include test equipment error. Adjustment of the instrument must be accomplished at an ambient temperature between +20°C and +30°C, and the instrument must have had a warm-up period of at least 20 minutes.

ADJUSTMENTS AFFECTED BY REPAIRS

Repairs to a circuit may affect one or more adjustment settings of the instrument. Table 5-1 identifies the adjustment(s) affected due to repairs or replacement of components on a circuit board. Refer to Table 5-1 if a partial procedure is performed or if a circuit requires readjustment due to repairs to a circuit. To use Table 5-1, first find, in the leftmost column, the circuit that was repaired. Then move to the right, across that row, until you come to a darkened square, move up the column and check the accuracy of the adjustment found at the heading of that column. Readjust if necessary.

PREPARATION FOR ADJUSTMENT

The instrument cabinet must be removed to perform the Adjustment Procedure. See the Cabinet remove and replace instructions located in the Maintenance section of the manual.

All test equipment items listed in Table 4-1 in the Performance Check Procedure section are required to accomplish a complete Adjustment Procedure. At the beginning of each subsection there is an equipment-required list showing only the test equipment necessary for performing the steps in that subsection. In this list, the item number following each piece of equipment corresponds to the item number listed in Table 4-1.

Before performing this procedure, do not preset any internal adjustments and do not change the -8.6 V power-supply adjustment. Altering this adjustment may necessitate a complete

readjustment of the instrument, whereas only a partial adjustment might otherwise be required. Only change an internal adjustment setting if a Performance Characteristic cannot be met with the original setting.

Before performing any procedure in this section, set the POWER switch to ON and allow a 20-minute warm-up period.

The most accurate display adjustments are made with a stable, well-focused, low-intensity display. Unless otherwise noted, adjust the INTENSITY, FOCUS, and Trigger LEVEL controls as needed to view the display.

Table 5-1
Adjustments Affected by Repairs

REPAIRS MADE	INTERNAL ADJUSTMENTS AFFECTED														
	-8.6 V ADJ	GRID BIAS AND GEOM	VAR BAL & INVERT BAL	VERTICAL GAIN	ATTENUATOR COMPENSATION	HIGH-FREQUENCY COMPENSATION	1-MS TIMING	MAGNIFIER GAIN	MAGNIFIER REGISTRATION	0.1-MS AND 0.1- μ S TIMING	HIGH-SPEED TIMING	X-Y GAIN AND OFFSET	TRIGGER OFFSET	TRIGGER SENSITIVITY	P-P AUTO LEVEL
POWER SUPPLIES	///														
VERTICAL ATTENUATORS															
PREAMPS & CHANNEL SW															
VERTICAL OUTPUT															
TRIGGER CIRCUIT															
SWEEP GENERATOR															
HORIZONTAL AMPLIFIER															
CRT															

6716-13

INDEX TO ADJUSTMENT PROCEDURE STEPS

Power Supply and CRT Display	Page
1. Check/Adjust Power Supply DC Levels	5-4
2. Adjust CRT Grid Bias	5-4
3. Adjust Astigmatism	5-5
4. Adjust Trace Alignment	5-5
5. Adjust Geometry	5-5

Vertical

1. Adjust Channel 1 Variable Balance	5-6
2. Adjust Channel 2 Variable Balance	5-6
3. Adjust Channel 2 Invert Balance	5-7
4. Adjust Vertical Gain	5-7
5. Check Deflection Accuracy and VOLTS/DIV Variable Range	5-7
6. Check Input Coupling	5-7
7. Check Position Range	5-8
8. Adjust Attenuator Compensation	5-8
9. Check Vertical ALT and CHOP Operation	5-9
10. Adjust CHOP Switch Balance	5-9
11. Check ADD MODE Operation	5-9
12. Adjust High-Frequency Compensation	5-9
13. Check Bandwidth	5-10
14. Check Channel Isolation	5-10

15. Check Common-Mode Rejection Ratio	5-10
---	------

Horizontal

1. Adjust 1-ms Timing	5-11
2. Adjust Magnifier Gain	5-11
3. Adjust Magnifier Registration	5-11
4. Check Position Range	5-12
5. Check Variable Range	5-12
6. Adjust 0.1-ms and 0.1- μ s Timing	5-12
7. Adjust High-Speed Timing	5-12
8. Check Timing Accuracy and Linearity	5-12
9. Adjust X-Y Gain and Offset	5-13
10. Check X Bandwidth	5-14
11. Check Sweep Holdoff	5-14

Trigger

1. Adjust Trigger Offset	5-15
2. Adjust Trigger Sensitivity	5-15
3. Adjust Slope Balance	5-16
4. Adjust Auto Level	5-16
5. Check Internal Triggering	5-16
6. Check External Trigger Range	5-16
7. Check External Trigger Range	5-17
8. Check Single Sweep Operation	5-17

External Z-Axis and Probe Adjust

1. Check External Z-Axis Operation	5-18
2. Check Probe Adjust Operation	5-18

POWER SUPPLY AND CRT DISPLAY

Equipment Required (See Table 4-1):

- | | |
|--------------------------------------|-----------------------------|
| Leveled Sine-Wave Generator (Item 2) | 50-Ω Coaxial Cable (Item 6) |
| Time-Mark Generator (Item 3) | 50-Ω Termination (Item 8) |
| Digital Voltmeter (Item 5) | Alignment Tool (Item 11) |

See **ADJUSTMENT LOCATIONS 1** and **ADJUSTMENT LOCATIONS 2**
at the back of this manual for adjustment locations.

INITIAL CONTROL SETTINGS

- | | |
|---------------------------|-----------------|
| INTENSITY | Visible display |
| Vertical | |
| POSITION (both) | Midrange |
| MODE | CH 1, NORM |
| VOLTS/DIV (both) | 10 mV |
| VOLTS/DIV Variable (both) | CAL detent |
| AC-GND-DC (both) | GND |
| Horizontal | |
| POSITION | Midrange |
| MAG | X1 |
| SEC/DIV | X-Y (fully ccw) |
| SEC/DIV Variable | CAL detent |
| Trigger | |
| SLOPE | Positive (↗) |
| LEVEL | Midrange |
| MODE | P-P AUTO |
| SOURCE | EXT, EXT |

- a. Connect the digital voltmeter low lead to chassis ground and connect the volts lead to the -8.6 V₁ supply (W989).
- b. CHECK—Voltmeter reading is -8.5 V to -8.7 V. If the reading is within these limits, skip to part d.
- c. ADJUST—The -8.6 V₁ Adj potentiometer (R916) for a voltmeter reading of -8.6 V.
- d. CHECK—Voltage levels of the remaining power supplies listed in Table 5-2 are within the specified limits.
- e. Disconnect the test equipment from the instrument.

Table 5-2

Power Supply Limits

Power Supply	Test Point	Reading (Volts)
-8.6 V ₁	W989	-8.56 to -8.64
+5.0 V ₁	W991	+4.85 to +5.15
+8.6 V ₁	W987	+8.34 to +8.86
+102.0 V	W984	+98.9 to +105.0
+205.0 V	W985	+198.8 to +211.1
+22 V unreg	W752	Approx. +24 V

PROCEDURE STEPS

1. Check/Adjust Power Supply DC Levels (R916)

NOTE

Review the information at the beginning of the Adjustment Procedure before starting this step.

2. Adjust CRT Grid Bias (R851)

- a. Adjust the front-panel FOCUS control to produce a well-defined dot.

b. Rotate the INTENSITY control fully counterclockwise.

c. ADJUST—Grid Bias (R851) for a visible dot, then back off the Grid Bias potentiometer until the dot just disappears.

3. Adjust Astigmatism (R870)

a. Set:

Vertical MODE	CH 1
Channel 1 AC-GND-DC	DC
SEC/DIV	5 μ s
Trigger Source	CH 1

b. Connect the leveled sine-wave generator output via a 50- Ω coaxial cable and a 50- Ω termination to the CH 1 OR X input connector.

c. Set the generator to produce a 50-kHz, 4-division display.

d. ADJUST—Astig (R870) and the front-panel FOCUS control for the best defined waveform.

e. Disconnect the test equipment from the instrument.

4. Adjust Trace Alignment

a. Position the trace to the center horizontal graticule line.

b. ADJUST—Front-panel TRACE ROTATION control for optimum alignment of the trace with the center horizontal graticule line.

5. Adjust Geometry (R871)

a. Set:

CH 1 VOLTS/DIV	50 mV
SEC/DIV	0.1 ms

b. Connect 50-ms time markers from the time-mark generator via a 50- Ω coaxial cable and a 50- Ω termination to the CH 1 OR X input connector.

c. Position the baseline part of the display below the bottom horizontal graticule line using the CH 1 POSITION control.

d. Adjust the SEC/DIV Variable control for five markers per division.

e. ADJUST—Geom (R871) for minimum curvature of the time markers at the left and right edges of the graticule.

f. Set Channel 1 AC-GND-DC switch to GND.

g. ADJUST—Geom (R871) for minimum curvature of the baseline trace when positioned at the top and bottom horizontal graticule lines using the CH 1 POSITION control.

h. Set the Channel 1 AC-GND-DC switch to DC.

i. Repeat parts e through h for optimum compromise between the vertical and horizontal displays.

j. Disconnect the test equipment from the instrument.

VERTICAL

Equipment Required (See Table 4-1):

Calibration Generator (Item 1)	10X Attenuator (Item 9)
Leveled Sine-Wave Generator (Item 2)	Miniature Probe Tip to BNC Adapter (Item 10)
50-Ω Coaxial Cable (Item 6)	Alignment Tool (Item 11)
Dual-Input Coupler (Item 7)	10X Probe (Item 12)
50-Ω Termination (Item 8)	

See **ADJUSTMENT LOCATIONS 1** and **ADJUSTMENT LOCATIONS 2**
at the back of this manual for adjustment locations.

INITIAL CONTROL SETTINGS

Vertical

POSITION (both)	Midrange
MODE	CH 1, NORM
VOLTS/DIV (both)	5 mV
VOLTS/DIV Variable (both)	Cal detent
AC-GND-DC (both)	GND

Horizontal

POSITION	Midrange
MAG	X1
SEC/DIV	0.5 ms
SEC/DIV Variable	CAL detent

Trigger

SLOPE	Positive (⌋)
LEVEL	Midrange
MODE	P-P AUTO
SOURCE	EXT, EXT

- b. Position the trace on the center horizontal graticule line using the CH 1 POSITION control.
- c. Rotate the CH 1 VOLTS/DIV Variable control clockwise to the CAL detent.
- d. ADJUST—CH 1 Var Bal (R33) to set the trace to the center horizontal graticule line.
- e. Repeat parts a through d until there is no trace shift between the fully clockwise and the fully counterclockwise positions of the CH 1 VOLTS/DIV Variable control.
- f. Return the CH 1 VOLTS/DIV Variable control to the CAL detent.

2. Adjust Channel 2 Variable Balance (R83)

- a. Set Vertical MODE switch to CH 2.
- b. Rotate the CH 2 VOLTS/DIV Variable control fully counterclockwise.
- c. Position the trace on the center horizontal graticule line using the CH 2 POSITION control.
- d. Rotate the CH 2 VOLTS/DIV Variable control clockwise to the CAL detent.
- e. ADJUST—CH 2 Var Bal (R83) to set the trace to the center horizontal graticule line.
- f. Repeat parts a through d until there is no trace shift between the fully clockwise and the fully counterclockwise positions of the CH 1 VOLTS/DIV Variable control.

PROCEDURE STEPS

1. Adjust Channel 1 Variable Balance (R33)

- a. Rotate the CH 1 VOLTS/DIV Variable control fully counterclockwise.

g. Return the CH 1 VOLTS/DIV Variable control to the CAL detent

3. Adjust Channel 2 Invert Balance (R84)

- a. Position the trace on the center horizontal graticule line using the Channel 2 POSITION control.
- b. Set Vertical MODE switch to CH 2 INVERT.
- c. ADJUST—CH 2 Invert Bal (R84) to set the trace to the center horizontal graticule line.
- d. Set Vertical MODE switch to NORM.
- e. Repeat parts a through d until there is no trace shift when switching from NORM to CH 2 INVERT.

4. Adjust Vertical Gain (R145 and R195)

a. Set:

Vertical MODE	CH 1, NORM
CH 1 VOLTS/DIV Variable	CAL detent
AC—GND—DC (both)	DC
Trigger SOURCE	VERT MODE

b. Connect a 20-mV, standard-amplitude signal from the calibration generator via a 50-Ω coaxial cable to the CH 1 OR X input connector.

c. Center the display within the graticule using the CH 1 POSITION control.

d. ADJUST—CH 1 Gain (R145) for an exact 4-division display.

e. Move the test-signal cable from the CH 1 OR X input connector to the CH 2 OR Y input connector.

f. Set the Vertical MODE switch to CH 2.

g. Center the display within the graticule using the CH 2 POSITION control.

h. ADJUST—CH 2 Gain (R195) for an exact 4-division display.

i. Repeat parts b through h until the gain of the two channels is identical.

5. Check Deflection Accuracy and VOLTS/DIV Variable Range

a. CHECK—Deflection accuracy is within the limits given in Table 5-3 for each CH 1 VOLTS/DIV switch setting and corresponding standard-amplitude signal. When at the 20-mV VOLTS/DIV switch setting,

rotate the CH 1 VOLTS/DIV Variable control fully counterclockwise and CHECK that the display decreases to two divisions or less. Then return the CH 1 VOLTS/DIV Variable control to the CAL detent and continue with the 50-mV check.

b. Move the cable from the CH 1 OR X input connector to the CH 2 OR Y input connector. Set the Vertical MODE switch to CH 2.

c. Repeat part b using the Channel 2 controls.

**Table 5-3
Deflection Accuracy Limits**

VOLTS/DIV Switch Setting	STANDARD Amplitude Signal	ACCURACY Limits (Divisions)
5 mV	20 mV	3.88 to 4.12
10 mV	50 mV	4.85 to 5.15
20 mV	0.1 V	4.85 to 5.15
50 mV	0.2 V	3.88 to 4.12
0.1 V	0.5 V	4.85 to 5.15
0.2 V	1 V	4.85 to 5.15
0.5 V	2 V	3.88 to 4.12
1 V	5 V	4.85 to 5.15
2 V	10 V	4.85 to 5.15
5 V	20 V	3.88 to 4.12

6. Check Input Coupling

a. Set the AC—GND—DC switches (both channels) to GND.

b. Position the trace on the center horizontal graticule line using the CH 2 POSITION control.

c. Change the generator output to 50 mV.

d. Set the Channel 2 AC—GND—DC switch to AC.

e. CHECK—The display is centered about the center horizontal graticule line.

f. Set the Channel 2 AC—GND—DC switch to DC.

g. CHECK—The display is ground referenced on the center horizontal graticule line.

h. Move the test-signal cable from the CH 2 OR Y input connector to the CH 1 OR X input connector.

- i. Set the Vertical MODE switch to CH 1.
- j. Repeat parts b through g using the Channel 1 controls.

7. Check Position Range

a. Set:

VOLTS/DIV (both)	10 mV
AC-GND-DC (both)	AC
SEC/DIV	0.2 ms
Trigger COUPLING	AC

- b. Set the calibration generator for 0.1 V.
- c. Adjust the CH 1 VOLTS/DIV Variable control to produce a 5.25-division display.
- d. Set the CH 1 VOLTS/DIV to 5 mV.
- e. Set the calibration generator to produce a 0.2 V signal.
- f. CHECK—The bottom and top of the trace may be positioned above and below the center horizontal graticule line by rotating the CH 1 POSITION control fully clockwise and counterclockwise respectively.
- g. Move the cable from the CH 1 OR X input connector to the CH 2 OR Y input connector.
- h. Set the Vertical MODE switch to CH 2.
- i. Repeat parts b through f using the Channel 2 controls.
- j. Disconnect the test equipment from the instrument.

8. Adjust Attenuator Compensation

a. Set:

VOLTS/DIV (both)	10 mV
AC-GND-DC (both)	DC

- b. Connect the high-amplitude, square-wave output from the calibration generator via a 50-Ω termination, a miniature probe tip to BNC adapter, and the 10X probe to the CH 2 OR Y input connector.
- c. Set the generator to produce a 1-kHz, 5-division display and compensate the probe using the probe compensation adjustment (see the probe instruction manual).

d. Replace the probe and miniature probe tip to BNC adapter with a 50-Ω coaxial cable and 50-Ω termination.

e. Set the generator to produce a 5-division display.

f. ADJUST—Trimmer "1" for flattest response on the square wave signal. See Figure 5-1 for location of the trimmers.

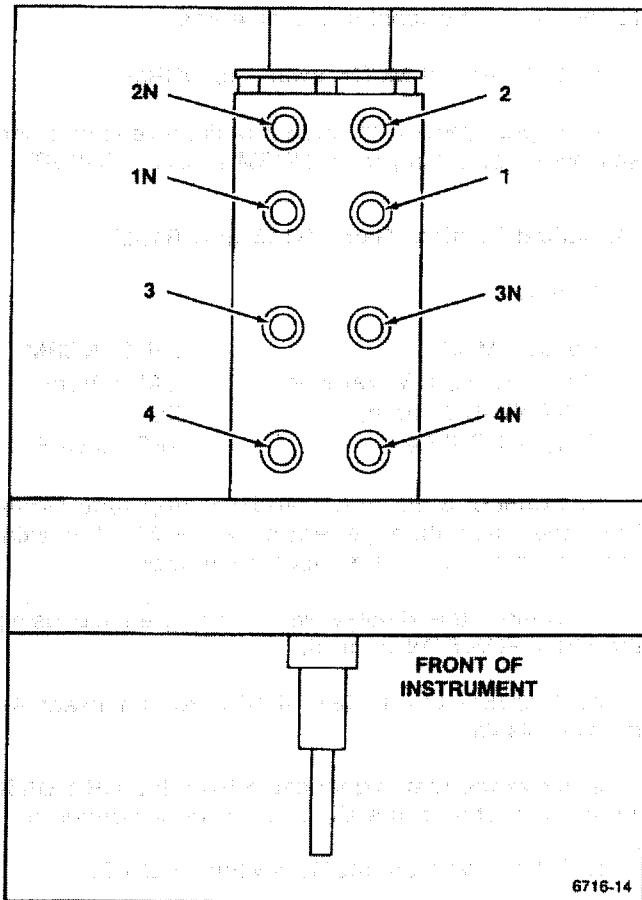

Figure 5-1. Attenuator trimmer adjustments.

g. Replace the 50-Ω coaxial cable and 50-Ω termination with the probe and miniature probe tip to BNC adapter.

h. Set the generator to produce a 5-division square wave.

i. ADJUST—Trimmer "1N" for flattest response on square wave.

j. Set the CH 2 VOLTS/DIV switch to 20 mV.

k. Repeat parts d through i except adjust the "2" and "2N" trimmers in parts f and i respectively.

i. Set the CH 2 VOLTS/DIV switch to 50 mV.

m. Repeat parts d through i except adjust the "3" and "3N" trimmers in parts f and i respectively.

n. Set the CH 2 VOLTS/DIV switch to 0.5 V.

o. Repeat parts d through i except adjust the "4" and "4N" trimmers in parts f and i respectively.

p. Set the Vertical MODE switch to CH 1.

q. Repeat parts b through p for the Channel 1 Attenuators.

r. Disconnect the test equipment from the instrument.

9. Check Vertical ALT Operation

a. Set:

AC-GND-DC (both)	GND
Vertical MODE	BOTH, NORM, and ALT
SEC/DIV	0.1 s
Trigger SOURCE	CH 1

b. Position the Channel 1 and Channel 2 traces about two divisions apart using the CH 1 and CH 2 POSITION controls.

c. CHECK—Channel 1 and Channel 2 traces move across the screen alternately.

d. Set Vertical switch to CHOP.

e. CHECK—Channel 1 and Channel 2 traces move across the screen at the same time.

10. Adjust CHOP Switch Balance (R140)

a. Set:

SEC/DIV	1 ms
Trigger MODE	NORM
Trigger SOURCE	VERT MODE

b. Connect the 10X probe to the rear of R242 on top of the A1—Main circuit board and adjust test oscilloscope for a 4-division display.

c. ADJUST—Chop-Sw Bal (R140) for no triggering on chop segments when rotating the Trigger LEVEL control.

11. Check ADD MODE Operation

a. Set:

VOLTS/DIV (both)	20 mV
AC-GND-DC (both)	DC
Vertical MODE	BOTH, NORM, and ALT
SEC/DIV	0.5 ms
Horizontal MODE	X1
Trigger SOURCE	CH 1

b. Position both traces on the center horizontal graticule line using the CH 1 and CH 2 POSITION controls.

c. Set the calibration generator to produce a 50-mV signal.

d. Connect the output of the calibration generator to both the CH 1 OR X input and the CH 2 OR Y input with dual-input coupler.

e. Check that both channels show a 2.5-division display.

f. Set: Vertical MODE switch to ADD.

g. CHECK—The resultant display is five divisions 3% (4.85 to 5.15 divisions).

h. Disconnect the test equipment from the instrument.

12. Adjust High-Frequency Compensation (C241, C242, C243, and R241)

a. Set:

VOLTS/DIV (both)	10 mV
Vertical MODE	CH 1
SEC/DIV	0.2 ms

b. Connect the positive-going, fast-rise, square-wave output from the calibration generator via a 50-Ω coaxial cable, a 10X attenuator, and a 50-Ω termination to the CH 1 OR X input connector.

c. Set the generator to produce a 1-MHz, 5-division display.

d. Set the top of the display to the center horizontal graticule line using the CH 1 POSITION control.

e. ADJUST—HF Comp (C242 and C243) for the 5% or less overshoot (0.3 division) on the displayed signal.

Adjustment Procedure—2205 Service

f. ADJUST—HF Comp (C241 and R241) for best flat top on the front corner.

g. Repeat parts e and f until on further improvement is noted.

h. Set the CH 1 VOLTS/DIV switch to 5 mV.

i. Set the generator to produce a 5-division display.

j. Check for aberrations of 5% (0.3 division) or less.

k. Repeat part j for each CH 1 VOLTS/DIV switch settings from 5 mV through 0.5 V. Adjust the generator output and add or remove the 10X attenuator as necessary to maintain a 5-division display at each VOLTS/DIV switch setting.

l. Move the cable from the CH 1 OR X input connector to the CH 2 OR Y input connector. Set the Vertical MODE switch to CH 2.

m. Repeat part k for Channel 2.

n. Disconnect the test equipment from the instrument.

NOTE

Install the instrument cabinet for the remaining vertical checks and allow a 20-minute warm-up period before continuing with the "Adjustment Procedure". See the "Cabinet" remove and replace instructions located in the "Maintenance" section of the manual.

13. Check Bandwidth

a. Set:

VOLTS/DIV (both)	5 mV
Vertical MODE	CH 1
SEC/DIV	10 ms
Trigger SOURCE	VERT MODE

b. Connect the leveled sine-wave generator output via a 50- Ω coaxial cable and a 50- Ω termination to the CH 1 OR X input connector.

c. Set the generator to produce a 50-kHz, 6-division display.

d. Increase the sine-wave frequency until a 4.2-division display is obtained.

e. CHECK—the frequency is greater than 20 MHz.

f. Repeat parts c through e for all CH 1 VOLTS/DIV switch settings, up to the output-voltage upper limit of the sine-wave generator being used.

g. Move the cable from the CH 1 OR X input connector to the CH 2 OR Y input connector. Set the Vertical MODE switch to CH 2.

h. Repeat parts c through e for all CH 2 VOLTS/DIV switch settings, up to the output-voltage upper limit of the sine-wave generator being used.

14. Check Channel Isolation

a. Set:

CH 1 VOLTS/DIV	0.5 V
CH 2 VOLTS/DIV	1 V
Channel 1 AC-GND-DC	GND
SEC/DIV	0.05 ms

b. Set the generator to produce a 20-MHz, 5-division display.

c. Set CH 2 VOLTS/DIV switch to 0.5 V for a 10-division display.

d. Set Vertical MODE switch to CH 1 and ALT.

e. CHECK—The display amplitude is less than 0.1 division.

f. Move the test-signal cable from the CH 2 OR Y input connector to the CH 1 OR X input connector.

g. Set:

Vertical MODE	CH 2
Channel 1 AC-GND-DC	DC
Channel 2 AC-GND-DC	GND

h. CHECK—The display amplitude is less than 0.1 division.

i. Disconnect the test equipment from the instrument.

15. Check Common-Mode Rejection Ratio

a. Set:

VOLTS/DIV (both)	10 mV
Channel 2 AC-GND-DC	DC
Vertical MODE	BOTH, NORM, and ALT

b. Connect the leveled sine-wave generator output via a 50- Ω coaxial cable, a 50- Ω termination, and a dual-input coupler to the CH 1 OR X and CH 2 OR Y input connectors.

c. Set the generator to produce a 10-MHz, 6-division display.

f. Disconnect the test equipment from the instrument.

d. Set Vertical MODE switch to CH 2 INV and ADD.

e. CHECK—Display amplitude is 0.6 division or less.

NOTE

To continue with the "Adjustment Procedure", remove the instrument cabinet and allow a 20-minute warm-up period. See the "Cabinet" removal instructions located in the "Maintenance" section of the manual.

HORIZONTAL

Equipment Required (See Table 4-1):

Calibration Generator (Item 1)	50- Ω Coaxial Cable (Item 6)
Leveled Sine-Wave Generator (Item 2)	50- Ω Termination (Item 8)
Time-Mark Generator (Item 3)	Alignment Tool (Item 11)
Test Oscilloscope (Item 4)	

See **ADJUSTMENT LOCATIONS 1** and **ADJUSTMENT LOCATIONS 2**
at the back of this manual for test point and adjustment locations.

INITIAL CONTROL SETTINGS

NOTE

Vertical

POSITION (both)	Midrange
MODE	CH 1
VOLTS/DIV (both)	0.5 V
VOLTS/DIV Variable (both)	Cal detent
AC-GND-DC (both)	DC

Horizontal

POSITION	Midrange
MAG	X1
SEC/DIV	1 ms
SEC/DIV Variable	CAL detent

Trigger

SLOPE	Positive (\neg)
LEVEL	Midrange
MODE	P-P AUTO
SOURCE	CH 1

When making timing measurements, use the tips of the time markers positioned at the center horizontal graticule line as the measurement reference points.

c. ADJUST—X1 Gain (R744) for one marker per division over the center eight divisions.

2. Adjust Magnifier Gain (R777)

a. Set the MAG switch to X10.

b. Select 100 μ s time markers from the time-mark generator.

c. Align the first time marker with the first (extreme left) vertical graticule line using the Horizontal POSITION control.

d. ADJUST—X10 Mag Gain (R777) for 1 time marker per division.

3. Adjust Magnifier Registration (R782)

a. Set the SEC/DIV switch to 0.2 ms.

b. Select 1 ms time markers from the time-mark generator.

c. Position the middle time marker to the center vertical graticule line using the Horizontal POSITION control.

d. Set the MAG switch from X10 to X1 position.

e. ADJUST—Mag Reg (R782) to position the middle time marker to the center vertical graticule line.

PROCEDURE STEPS

1. Adjust 1-ms Timing (R744)

a. Connect 1-ms time markers from the time-mark generator via a 50- Ω coaxial cable and a 50- Ω termination to the CH 1 OR X input connector.

b. Align the first time marker with the first (extreme left) vertical graticule line using the Horizontal POSITION control.

f. Set the MAG switch from X1 to X10 position and CHECK for no horizontal shift in the time marker.

g. Repeat parts c through f until no further improvement is noted.

4. Check Position Range

a. Set:

SEC/DIV	0.1 ms
Horizontal MAG	X1

b. Select 0.1 ms time markers from the time-mark generator.

c. CHECK—The start of the sweep can be positioned to the right of the center vertical graticule line by rotating the Horizontal POSITION control fully clockwise.

d. CHECK—The tenth time marker can be positioned to the left of the center vertical graticule line by rotating the Horizontal POSITION control fully counterclockwise.

e. Select 0.5 ms time markers from the time-mark generator.

f. Align the 3rd time marker with the center vertical graticule line using the Horizontal POSITION control.

g. Set the Horizontal MAG switch to X10.

h. Check—Magnified time marker can be positioned to the left of the center vertical graticule line by rotating the Horizontal POSITION control fully counterclockwise.

i. Check—The tenth time marker can be positioned to the right of the center vertical graticule line by rotating the Horizontal POSITION control fully clockwise.

5. Check Variable Range

a. Set Horizontal MAG switch to X1 and center the display.

b. Set the SEC/DIV Variable control knob fully counterclockwise.

c. CHECK—The spacing between time markers is 2 divisions or less.

d. Return the SEC/DIV Variable knob to the CAL detent position.

6. Adjust 0.1-ms and 0.1- μ s Timing (R722 and C703)

a. Set the SEC/DIV switch to 0.1 ms.

b. Select 0.1-ms time markers from the time-mark generator.

c. ADJUST—0.1-ms Timing (R722) for 1 marker per division.

d. Set the SEC/DIV switch to 0.1 μ s.

e. Select 0.1- μ s time markers from the time-mark generator.

f. ADJUST—0.1- μ s Timing (C703) for 1 marker per division.

7. Adjust High-Speed Timing (C783, C794)

a. Set:

Channel 1 AC-GND-DC	AC
Horizontal MAG	X10

b. Select 20-ns time markers from the time-mark generator and set the display for maximum amplitude within the graticule area.

c. Adjust the Trigger LEVEL control for a stable triggered display.

d. ADJUST—HS Timing (C783 and C794) for two divisions between each time marker.

NOTE

The 20-ns time-markers tips are rounded off and cannot be used as measurement reference points. Use the rising edge of the time markers as measurement reference points to adjust the high-speed timing capacitors. Vertically adjust the 50% point of the time markers on the center horizontal graticule line.

8. Check Timing Accuracy and Linearity

a. Set:

CH VOLTS/DIV	0.5 V
Horizontal MAG	X1

b. Select 0.1- μ s time markers from the time-mark generator.

c. Adjust the Trigger LEVEL control for a stable, triggered display.

Adjustment Procedure—2205 Service

d. Use the Horizontal POSITION control to align the second time marker with the second vertical graticule line.

e. CHECK—Timing accuracy is within 3% (0.24 division at the tenth vertical graticule line), and linearity is within 5% (0.10 division over any two of the center eight divisions).

NOTE

When checking the timing accuracy for SEC/DIV switch settings from 50 ms to 0.5 s, watch the time marker tips only at the second and tenth vertical graticule lines while adjusting the Horizontal POSITION control.

f. Repeat parts c through e for the remaining SEC/DIV and time-mark-generator setting combinations shown in Table 5-4 under the "X1 Normal" column.

g. Set:

SEC/DIV	0.1 μ s
Horizontal MAG	X10

h. Select 20-ns time markers from the time-mark generator.

i. Use the Horizontal POSITION controls to align the first time marker that is 50 ns beyond the start of the sweep with the second vertical graticule line.

j. CHECK—Timing accuracy is within 4% (0.32 division at the tenth vertical graticule line), and linearity is within 7% (0.14 division over any 2 of the center 8 divisions). Exclude any portion of the sweep past the 50th magnified division.

k. Repeat parts i and j for the remaining SEC/DIV and time-mark generator setting combination shown in Table 5-4 under the "X10 Magnified" column.

l. Disconnect the test equipment from the instrument.

9. Adjust X-Axis Gain (R395)

a. Set:

VOLTS/DIV (both)	10 mV
SEC/DIV	X-Y
Horizontal MAG	X1

Table 5-4

Settings for Timing Accuracy Checks

SEC/DIV Switch Setting	Time-Mark Generator Setting	
	X1 Normal	X10 Magnified
0.1 μ s	0.1 μ s	20 ns
0.2 μ s	0.2 μ s	20 ns
0.5 μ s	0.5 μ s	50 ns
1 μ s	1 μ s	0.1 μ s
2 μ s	2 μ s	0.2 μ s
5 μ s	5 μ s	0.5 μ s
10 μ s	10 μ s	1 μ s
20 μ s	20 μ s	2 μ s
50 μ s	50 μ s	5 μ s
0.1 ms	0.1 ms	10 μ s
0.2 ms	0.2 ms	20 μ s
0.5 ms	0.5 ms	50 μ s
1 ms	1 ms	0.1 ms
2 ms	2 ms	0.2 ms
5 ms	5 ms	0.5 ms
10 ms	10 ms	1 ms
20 ms	20 ms	2 ms
50 ms	50 ms	5 ms
0.1 s	0.1 s	10 ms
0.2 s	0.2 s	20 ms
0.5 s	0.5 s	50 ms

b. Connect a 50-mV, standard-amplitude signal from the calibration generator via a 50- Ω coaxial cable to the CH 1 OR X input connector.

c. ADJUST—X Gain (R395) for exactly 5 divisions of horizontal deflection.

10. Adjust X Offset (R736)

a. Set:

Channel 1 AC-GND-DC	GND
SEC/DIV	1 ms

b. Position the trace vertically to the center horizontal graticule line.

c. Position the trace horizontally so the start of the trace begins at the first vertical graticule line (extreme left).

d. Set the SEC/DIV switch to X-Y (fully counterclockwise).

e. ADJUST—X Offset (R736) to position the spot at the seventh vertical graticule line.

f. Disconnect the test equipment from the instrument.

10. Check X Bandwidth

a. Set:

VOLTS/DIV (both) 50 mV
 AC-GND-DC (both) DC
 Trigger SOURCE CH 1

b. Connect the leveled sine-wave generator output via a 50-Ω coaxial cable and a 50-Ω termination to the CH 1 OR X input connector.

c. Set the generator to produce an 8-division horizontal display at an output frequency of 50 kHz.

d. Increase the signal frequency until the horizontal deflection (X-axis) is equal to 5.7 divisions in length.

e. CHECK—The frequency is greater than 2 MHz.

f. Disconnect the test equipment from the instrument.

11. Check Sweep Holdoff

a. Set:

VOLTS/DIV (both) 1 V
 AC-GND-DC (both) GND
 SEC/DIV 1 ms
 Trigger SOURCE EXT, EXT

b. Connect the test oscilloscope's 10X probe tip to the front end of R704 (toward the front panel). R704 is on the Timing circuit board.

c. CHECK—Holdoff time is between 1.5 ms to 3.0 ms.

d. Repeat part c for SEC/DIV switch settings in Table 5-5.

e. Disconnect the 10X probe from R704.

Table 5-5
Settings for Holdoff Checks

SEC/DIV	Holdoff Time
0.1 ms	0.2 ms to 0.3 ms
10 μs	15 μs to 30 μs
1 μs	1.5 μs to 3.0 μs

TRIGGER

Equipment Required (See Table 4-1):

Leveled Sine-Wave Generator (Item 2)
 50-Ω Coaxial Cable (Item 6)
 Dual-Input Coupler (Item 7)

50-Ω Termination (Item 8)
 Alignment Tool (Item 11)

See **ADJUSTMENT LOCATIONS 1**

at the back of this manual for adjustment locations.

INITIAL CONTROL SETTINGS

Vertical

POSITION (both)	Midrange
MODE	BOTH, NORM and ALT
VOLTS/DIV (both)	50 mV
VOLTS/DIV Variable (both)	Cal detent
AC-GND-DC (both)	DC

Horizontal

POSITION	Midrange
MAG	X1
SEC/DIV	2 μs
SEC/DIV Variable	CAL detent

Trigger

SLOPE	Positive (↗)
LEVEL	Midrange
MODE	P-P AUTO
SOURCE	CH 2

b. Connect the digital voltmeter low lead to chassis ground and the high (volts) lead to TP350 (base of Q410).

c. CHECK—The offset voltage reading is less than 100 mV. Note the reading for use in part e.

d. Set the Trigger SOURCE switch to CH 1.

e. ADJUST—Trig Offset Bal (R338) so that the voltage reading is the same as that obtained in part c.

f. Set the Trigger SOURCE switch to CH 2.

g. Repeat parts c through f until there is 1 mV or less difference in the voltmeter readings between the CH 1 and CH 2 positions of the Trigger SOURCE switch.

h. Disconnect the test equipment from the instrument.

2. Adjust Trigger Sensitivity (R489)

a. Set:

Vertical MODE	CH 1
CH 1 VOLTS/DIV	0.1 V
AC-GND-DC (both)	AC
SEC/DIV	10 μs
Trigger SOURCE	VERT MODE

b. Connect the leveled sine-wave generator output via a 50-Ω cable and a 50-Ω termination to the CH 1 OR X input connector.

c. Set the generator to produce a 50-kHz, 2.2-division display.

PROCEDURE STEPS

1. Adjust Trigger Offset Balance(R338)

a. Set the Channel 1 trace and the Channel 2 trace to the center horizontal graticule line using the Channel 1 and Channel 2 POSITION controls.

d. Set the CH 1 VOLTS/DIV switch to 1 V.

e. ADJUST—Trig Sensitivity (R489) while rotating the Trigger LEVEL control slowly so that the trigger is just able to be maintained.

f. CHECK—The TRIG'D/READY LED is on when triggered.

3. Adjust Slope Balance (R481)

a. Set the CH 1 VOLTS/DIV switch to 50 mV.

b. Set the generator to produce a 4-division display.

c. ADJUST—Slope Bal (R481) for a downward vertical shift of 0.22-division at the start of the sweep when changing the Trigger SLOPE switch between the positive (↗) and negative (↘) positions.

4. Adjust Auto Level (R445 and R446)

a. Set:

Trigger SLOPE	Positive (↗)
Trigger LEVEL	Fully clockwise

b. Set the generator to produce a 5-division display.

c. Set the CH 1 VOLTS/DIV switch to 0.5 V.

d. ADJUST—(+) Auto Level (R446) so that the vertical display just solidly triggers on the positive peak of the signal.

e. Set:

Trigger SLOPE	Negative (↘)
Trigger LEVEL	Fully counter-clockwise

f. ADJUST—(-) Auto Level (R445) so that the display just solidly triggers on the negative peak of the signal.

5. Check Internal Triggering

a. Set:

CH 1 VOLTS/DIV	5 mV
CH 2 VOLTS/DIV	50 mV
SEC/DIV	0.2 μs

b. Set the generator to produce a 5-MHz, 3-division display.

c. Set the CH 1 VOLTS/DIV switch to 50 mV.

d. CHECK—Stable display can be obtained by adjusting the Trigger LEVEL control for each switch combination given in Table 5-6. Ensure that the TRIG'D/READY LED comes on when triggered.

Table 5-6

Switch Combinations for Triggering Checks

Trigger MODE	Trigger SLOPE
NORM	Positive ↗
NORM	Negative ↘
P-P AUTO	Negative ↘
P-P AUTO	Positive ↗

e. Move the cable from the CH 1 OR X input connector to the CH 2 OR Y input connector. Set the Vertical MODE switch to CH 2.

f. Repeat part d.

g. Set:

SEC/DIV	0.1 μs
Horizontal MAG	X10

h. Set the generator to produce a 30-MHz, 1.0-division display.

i. Repeat part d.

j. Move the cable from the CH 2 OR Y input connector to the CH 1 OR X input connector. Set the Vertical Mode switch to CH 1.

k. Repeat part d.

l. Disconnect the test equipment from the instrument.

6. Check External Triggering

a. Set:

CH 1 VOLTS/DIV	20 mV
SEC/DIV	0.2 ms
Horizontal MODE	X1
Trigger MODE	P-P AUTO
Trigger SOURCE	EXT, EXT

b. Connect the leveled sine-wave generator output via a 50-Ω coaxial cable, a 50-Ω termination,

Adjustment Procedure—2205 Service

and a dual-input coupler to the CH 1 OR X input connector and EXT INPUT OR Z input connectors.

c. Set the generator to produce a 4-division (80 mV) horizontal display at an output frequency of 5 MHz.

d. CHECK—Stable display can be obtained by adjusting the Trigger LEVEL control for each switch combination given in Table 4-4.

e. Set:

CH 1 VOLT/DIV	50 mV
SEC/DIV	0.05 ms
Horizontal MODE	MAG

f. Set the leveled sine-wave generator to produce a 50-kHz, 3-division (150 mV) display.

g. Set the generator output to 30 MHz.

h. Repeat part d.

7. Check External Trigger Range

a. Set:

CH 1 VOLTS/DIV	0.5 V
SEC/DIV	20 ms
Trigger SLOPE	Positive (↗)

b. Set the leveled sine-wave generator to produce a 50-kHz, 6.4-division display.

c. Position the waveform equally about the center horizontal graticule line.

d. Set:

Trigger MODE	NORM
Trigger SOURCE	EXT, EXT

e. CHECK—Display is triggered along the entire positive slope of the waveform as the Trigger LEVEL control is rotated.

f. CHECK—Display is not triggered at either extreme of rotation of the Trigger LEVEL control.

g. Set the Trigger SLOPE switch to negative (↘).

h. CHECK—Display is triggered along the entire negative slope of the waveform as the Trigger LEVEL control is rotated.

i. CHECK—Display is not triggered at either extreme of rotation of the Trigger LEVEL control.

j. Disconnect the test equipment from the instrument.

8. Check Single Sweep Operation

a. Set:

CH 1 VOLTS/DIV	10 mV
SEC/DIV	0.5 ms
Trigger SOURCE	CH 1
Trigger SLOPE	Positive (↗)

b. Connect 50-mV, standard-amplitude signal from the calibration generator via a 50-Ω coaxial cable to the CH 1 OR X input connector.

c. Adjust the Trigger LEVEL control to obtain a stable display.

d. Set:

Channel 1 AC-GND-DC	GND
Trigger MODE	SGL SWP

e. Press the SGL SWP RESET button. The TRIG'D/READY LED illuminates and remains on.

f. Set the Channel 1 AC-GND-DC switch to DC.

NOTE

The INTENSITY control may require adjustment to observe the single-sweep trace.

g. CHECK—TRIG'D/READY LED goes out and a single sweep occurs.

h. Press the SGL SWP RESET button several times.

i. CHECK—A single-sweep trace occurs, and the TRIG'D/READY LED illuminates briefly every time the SGL SWP RESET button is pressed.

j. Disconnect the test equipment from the instrument.

EXTERNAL Z-AXIS AND PROBE ADJUST

Equipment Required (See Table 4-1):

Calibration Generator (Item 1)	50- Ω Termination (Item 8)
Two 50- Ω Coaxial Cables (Item 6)	10X Probe (Item 12)
Dual-Input Coupler (Item 7)	

INITIAL CONTROL SETTINGS

NOTE

Vertical

CH 1 POSITION	Midrange
MODE	CH 1, NORM
CH 1 VOLTS/DIV	1 V
CH 1 VOLTS/DIV Variable	CAL detent
Channel 1 AC-GND-DC	DC

The *INTENSITY* level may need adjustment to view the intensity modulation on the displayed waveform.

b. CHECK—For noticeable intensity modulation. The positive part of the sine wave should be of lower intensity than the negative part.

Horizontal

POSITION	Midrange
MAG	X1
SEC/DIV	20 ms
SEC/DIV Variable	CAL detent

c. Disconnect the test equipment from the instrument.

2. Check Probe Adjust Operation

a. Set:

CH 1 VOLTS/DIV	10 mV
SEC/DIV	0.5 ms
Trigger SOURCE	CH 1

b. Connect the 10X Probe to the CH 1 OR X input connector and clip the probe tip to the PROBE connector on the instrument front panel. If necessary, adjust the probe compensation for a flat-topped square-wave display.

c. CHECK—Display amplitude is 4.75 to 5.25 divisions.

d. Disconnect the probe from the instrument.

Trigger

SLOPE	Positive (\neg)
LEVEL	Midrange
MODE	P-P AUTO
SOURCE	EXT, EXT=Z

PROCEDURE STEPS

1. Check External Z-Axis Operation

a. Connect a 5-V standard-amplitude signal from the calibration generator via dual-input coupler to the CH 1 OR X and EXT INPUT OR Z connectors.

MAINTENANCE

This section contains information for conducting preventive maintenance, troubleshooting, and corrective maintenance on the instrument. Circuit

board removal procedures are included in the Corrective Maintenance part of this section.

STATIC-SENSITIVE COMPONENTS

The following precautions are applicable when performing any maintenance involving internal access to the instrument.

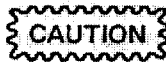

Static discharge can damage any semiconductor component in this instrument.

This instrument contains electrical components that are susceptible to damage from static discharge. Table 6-1 lists the relative susceptibility of various classes of semiconductors. Static voltages of 1 KV to 30 KV are common in unprotected environments.

When performing maintenance, observe the following precautions to avoid component damage:

1. Minimize handling of static-sensitive components.

2. Transport and store static-sensitive components or assemblies in their original containers or on a metal rail. Label any package that contains static-sensitive components or assemblies.

3. Discharge the static voltage from your body by wearing a grounded antistatic wrist strap while handling these components. Servicing static-sensitive components or assemblies should be performed only at a static-free work station by qualified service personnel.

4. Nothing capable of generating or holding a static charge should be allowed on the work station surface.

5. Keep the component leads shorted together whenever possible.

6. Pick up components by their bodies, never by their leads.

Table 6-1
Relative Susceptibility to Static-Discharge
Damage

Semiconductor Classes	Relative Susceptibility Levels ^a
MOS or CMOS microcircuits or discretes, or linear microcircuits with MOS inputs (Most Sensitive)	1
ECL	2
Schottky signal diodes	3
Schottky TTL	4
High-frequency bipolar transistors	5
JFET	6
Linear microcircuits	7
Low-power Schottky TTL	8
TTL (Least Sensitive)	9

^aVoltage equivalent for levels (voltage discharged from a 100-pF capacitor through a resistance of 100 Ω):

1 = 100 to 500 V

2 = 200 to 500 V

3 = 250 V

4 = 500 V

5 = 400 to 600 V

6 = 600 to 800 V

7 = 400 to 1000 V (est)

8 = 900 V

9 = 1200 V

7. Do not slide the components over any surface.

8. Avoid handling components in areas that have a floor or work-surface covering capable of generating a static charge.

9. Use a soldering iron that is connected to earth ground.

10. Use only approved antistatic, vacuum-type desoldering tools for component removal.

PREVENTIVE MAINTENANCE

INTRODUCTION

Preventive maintenance consists of cleaning, visual inspection, and checking instrument performance. When performed regularly, it may prevent instrument malfunction and enhance instrument reliability. The severity of the environment in which the instrument is used determines the required frequency of maintenance. An appropriate time to accomplish preventive maintenance is just before instrument adjustment.

GENERAL CARE

The cabinet minimizes accumulation of dust inside the instrument and should normally be in place when operating the oscilloscope. The optional front cover for the instrument provides both dust and damage protection for the front panel and crt. Whenever the instrument is stored or is being transported, the front cover should be used.



Do not use chemical cleaning agents that might damage the plastics used in this instrument. Use a nonresidue-type cleaner, preferably isopropyl alcohol or a solution of 1% mild detergent with 99% water. Before using any other type of cleaner, consult your Tektronix Service Center or representative.

INSPECTION AND CLEANING

The instrument should be inspected and cleaned as often as operating conditions require. Accumulation of dust in the instrument can cause overheating and component breakdown. Dust on components acts as an insulating blanket, preventing efficient heat dissipation. It also provides an electrical conduction

path that could result in instrument failure, especially under high-humidity conditions.

Exterior

INSPECTION. Inspect the external portions of the instrument for damage, wear, and missing parts; use Table 6-2 as a guide. Instruments that appear to have been dropped or otherwise abused should be checked thoroughly to verify correct operation and performance. Any problems found that could cause personal injury or could lead to further damage to the instrument should be repaired immediately.



Do not allow moisture to get inside the instrument during external cleaning. Use only enough liquid to dampen the cloth or applicator.

CLEANING. Loose dust on the outside of the instrument can be removed with a soft cloth or small soft-bristle brush. The brush is particularly useful for dislodging dirt on and around the controls and connectors. Dirt that remains can be removed with a soft cloth dampened in a mild detergent-and-water solution. Do not use abrasive cleaners.

A plastic light filter is provided with the oscilloscope. Clean the light filter and the crt face with a soft lint-free cloth dampened with either isopropyl alcohol or a mild detergent-and-water solution.

Interior

To gain access to internal portions of the instrument for inspection and cleaning, refer to the Removal and Replacement Instructions in the Corrective Maintenance part of this section.

Table 6-2
External Inspection Checklist

Item	Inspect For	Repair Action
Cabinet and Front Panel	Cracks, scratches, deformations, and damaged hardware or gaskets.	Touch up paint scratches and replace defective parts.
Front-panel controls	Missing, damaged, or loose knobs, buttons, and controls.	Repair or replace missing or defective items.
Connectors	Broken shells, cracked insulation, and deformed contacts. Dirt in connectors.	Replace defective parts. Clean or wash out dirt.
Carrying Handle	Correct operation.	Replace defective parts.
Accessories	Missing items or parts of items, bent pins, broken or frayed cables, and damaged connectors.	Replace damaged or missing items, frayed cables, and defective parts.
Cabinet and Front Panel	Cracks, scratches, deformations, and damaged hardware or gaskets.	Touch up paint scratches and replace defective parts.
Front-panel controls	Missing, damaged, or loose knobs, buttons, and controls.	Repair or replace missing or defective items.
Connectors	Broken shells, cracked insulation, and deformed contacts. Dirt in connectors.	Replace defective parts. Clean or wash out dirt.
Carrying Handle	Correct operation.	Replace defective parts.
Accessories	Missing items or parts of items, bent pins, broken or frayed cables, and damaged connectors.	Replace damaged or missing items, frayed cables, and defective parts.

INSPECTION. Inspect the internal portions of the instrument for damage and wear, using Table 6-3 as a guide. Deficiencies found should be repaired immediately. The corrective procedure for most visible defects is obvious; however, particular care must be taken if heat-damaged components are found. Overheating usually indicates other trouble in the instrument; therefore, it is important that the cause of overheating be corrected to prevent recurrence of the damage.

If any electrical component is replaced, conduct a performance check for the affected circuit and for other closely related circuits (see Section 4). If repair or replacement work is done on any of the power supplies, conduct a complete performance check and, if so indicated, an instrument readjustment (see Sections 4 and 5).

CAUTION

To prevent damage from electrical arcing, ensure that circuit boards and components are dry before applying power to the instrument.

CLEANING. To clean the interior, blow off dust with dry, low-pressure air (approximately 9 psi). Remove any remaining dust with a soft brush or a cloth dampened with a solution of mild detergent and water. A cotton-tipped applicator is useful for cleaning in narrow spaces and on circuit boards.

VOLT/DIV And SEC/DIV SWITCHES. These are maintenance free. DO NOT CLEAN.

Table 6-3
Internal Inspection Checklist

Item	Inspect For	Repair Action
Circuit Boards	Loose, broken, or corroded solder connections. Burned circuit boards. Burned, broken, or cracked circuit-run plating.	Clean solder corrosion with an eraser and flush with isopropyl alcohol. Resolder defective connections. Determine cause of burned items and repair. Repair defective circuit runs.
Resistors	Burned, cracked, broken, or blistered.	Replace defective resistors. Check for cause of burned component and repair as necessary.
Solder Connections	Cold solder or rosin joints.	Resolder joint and clean with isopropyl alcohol.
Capacitors	Damaged or leaking cases. Corroded solder on leads or terminals.	Replace defective capacitors. Clean solder connections and flush with isopropyl alcohol.
Wiring and Cables	Loose plugs or connectors. Burned, broken, or frayed wiring.	Firmly seat connectors. Repair or replace defective wires or cables.
Chassis	Dents, deformations, and damaged hardware.	Straighten, repair, or replace defective hardware.



Most spray-type circuit coolants contain Freon 12 as a propellant. Because many Freons adversely affect switch contacts, do not use spray-type coolants on the switches or attenuators. Carbon based solvents will damage the circuit board material.

LUBRICATION

Most of the potentiometers used in this instrument are permanently sealed and generally do not require periodic lubrication. All switches, both rotary- and lever-type, are installed with proper lubrication applied where necessary and will rarely require any additional lubrication. A regular periodic lubrication program for the instrument is, therefore, not recommended.

SEMICONDUCTOR CHECKS

Periodic checks of the transistors and other semiconductors in the oscilloscope are not recommended. The best check of semiconductor performance is actual operation in the instrument.

PERIODIC READJUSTMENT

To ensure accurate measurements, check the performance of this instrument every 2000 hours of operation, or if used infrequently, once each year. In addition, replacement of components may necessitate readjustment of the affected circuits.

Complete performance check and adjustment instructions are given in Sections 4 and 5. The performance check procedure can also be helpful in localizing certain troubles in the instrument. In some cases, minor problems may be revealed or corrected by readjustment. If only a partial adjustment is performed, see the interaction chart, Table 5-1, for possible adjustment interaction with other circuits.

TROUBLESHOOTING

INTRODUCTION

Preventive maintenance performed on a regular basis should reveal most potential problems before an instrument malfunctions. However, should troubleshooting be required, the following information is provided to facilitate location of a fault. In addition, the material presented in the Theory of Operation and Diagrams sections of this manual may be helpful while troubleshooting.

TROUBLESHOOTING AIDS

Schematic Diagrams

Complete schematic diagrams are located on tabbed foldout pages in the Diagrams section. Portions of circuitry mounted on each circuit board are enclosed by heavy black lines. The assembly number and name of the circuit are shown near either the top or the bottom edge of the enclosed area.

Functional blocks on schematic diagrams are outlined with a wide grey line. Components within the outlined area perform the function designated by the block label. The Theory of Operation uses these functional block names when describing circuit operation as an aid in cross-referencing between the theory and the schematic diagrams.

Component numbers and electrical values of components in this instrument are shown on the schematic diagrams. Refer to the first page of the Diagrams section for the reference designators and symbols used to identify components. Important voltages and waveform reference numbers (enclosed in hexagonal-shaped boxes) are also shown on each diagram. Waveform illustrations are located adjacent to their respective schematic diagram.

Circuit Board Illustrations

Circuit board illustrations showing the physical location of each component are provided for use in conjunction with each schematic diagram. Each circuit board illustration is found in the Diagrams section on the back of a foldout page, preceding the first schematic diagram(s) to which it relates.

The locations of waveform test points are marked on the circuit board illustrations with hexagonal outlined numbers corresponding to the waveform numbers on both the schematic diagram and the waveform illustrations.

Also provided in the Diagrams section is an illustration of the bottom side of the Main circuit board. This illustration aids in troubleshooting by showing the connection pads for the components mounted on the top side of the circuit board. By using this illustration, circuit tracing and probing for voltages and signals that are inaccessible from the top side of the circuit board may be achieved without dismantling portions of the instrument.

Circuit Board Locations

The placement of each circuit board in the instrument is shown in circuit board locator illustrations. These illustrations are located on foldout pages along with the circuit board illustration.

Circuit Board Interconnections

Circuit Board Interconnections (Diagram 9) is provided as an aid in tracing a signal path between circuit boards. All wire, plug, and jack numbers are shown along with their associated wire or pin numbers.

Power Distribution

Power Distribution (Diagram 8) is provided to aid in troubleshooting power-supply problems. This diagram shows the service jumper connections used to apply power to the various circuit boards. Excessive loading on a power supply by a circuit board fault may be isolated by disconnecting the appropriate service jumpers.

Grid Coordinate System

Each schematic diagram and circuit board illustration has a grid border along its left and top edges. A table located adjacent to each diagram lists the grid coordinates of each component shown on that diagram. To aid in physically locating components on the circuit board, this table also lists the grid coordinates of each component on the circuit board illustration.

Near each circuit board illustration is an alphanumeric listing of all components mounted on that circuit board. The second column in each listing identifies the schematic diagram in which each component can be found. These component-locator tables are especially useful when more than one schematic diagram is associated with a particular circuit board.

Component Color Coding

Information regarding color codes and markings of resistors and capacitors is located on the color-coding illustration (Figure 9-1) at the beginning of the Diagrams section.

RESISTOR COLOR CODE. Resistors used in this instrument are carbon-film, composition, or precision metal-film types. They are usually color coded with the EIA color code; however, some metal-film type resistors may have the value printed on the body. The color code is interpreted starting with the stripe nearest to one end of the resistor. Composition resistors have four stripes; these represent two significant digits, a multiplier, and a tolerance value. Metal-film resistors have five stripes representing three significant digits, a multiplier, and a tolerance value.

CAPACITOR MARKINGS. Capacitance values of common plastic capacitors and small electrolytics are marked on the side of the capacitor body. Small, machine-insertable capacitors are numerically coded in picofarads. The first two numbers are the significant digits and the third number (if a three-number code) is the number of zeros following the digits. When there are two numbers separated by the letter "R", the two numbers are the significant digits; the letter marks the radix (decimal point). Some examples of this type of capacitor coding are as follows:

475 = 47 00000 pF = 4.7 μ F
472 = 47 00 pF = 0.0047 μ F
471 = 47 0 pF
470 = 47 pF
4R7 = 4.7 pF

The code numbers may be difficult to locate and read on installed parts. Capacitor values may be found by referencing the circuit designation number in the Replaceable Electrical Parts list.

DIODE COLOR CODE. The cathode end of each glass-encased diode is indicated by either a stripe, a series of stripes or a dot. For most diodes marked with a series of stripes, the color combination of the stripes identifies three digits of the Tektronix Part Number, using the resistor color-code system. The

cathode and anode ends of a metal-encased diode may be identified by the diode symbol marked on its body.

Semiconductor Lead Configurations

Figure 9-2 in the Diagrams section shows the lead configurations for semiconductor devices used in the instrument. These lead configurations and case styles are typical of those used at completion of the instrument design. Vendor changes and performance improvement changes may result in changes of case styles or lead configurations. If the device in question does not appear to match the configuration shown in Figure 9-2, examine the associated circuitry or consult the manufacturer's data sheet.

TROUBLESHOOTING EQUIPMENT

The equipment listed in Table 4-1 of this manual, or equivalent equipment, may be useful when troubleshooting this instrument.

TROUBLESHOOTING TECHNIQUES

The following procedure is arranged in an order that enables checking simple trouble possibilities before requiring more extensive troubleshooting. The first four steps ensure proper control settings, connections, operation, and adjustment. If the trouble is not located by these checks, the remaining steps will aid in locating the defective component. When the defective component is located, replace it using the appropriate replacement procedure given under Corrective Maintenance in this section.

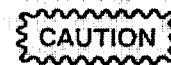

Before using any test equipment to make measurements on static-sensitive, current-sensitive, or voltage-sensitive components or assemblies, ensure that any voltage or current supplied by the test equipment does not exceed the limits of the component to be tested.

1. Check Control Settings

Incorrect control settings can give a false indication of instrument malfunction. If there is any question about the correct function or operation of any control, refer to either the Operating Information in Section 2 of this manual or to the Operators Manual.

2. Check Associated Equipment

Before proceeding, ensure that any equipment used with the instrument is operating correctly. Verify that input signals are properly connected and that the interconnecting cables are not defective. Check that the ac-power-source voltage to all equipment is correct.

To avoid electrical shock, disconnect the instrument from the ac power source before making a visual inspection of the internal circuitry.

3. Visual Check

Perform a visual inspection. This check may reveal broken connections or wires, damaged components, semiconductors not firmly mounted, damaged circuit boards, or other clues to the cause of an instrument malfunction.

WARNING

Dangerous potentials exist at several points throughout this instrument. If it is operated with the cabinet removed, do not touch exposed connections or components.

4. Check Instrument Performance and Adjustment

Check the performance of either those circuits where trouble appears to exist or the entire instrument. The apparent trouble may be the result of misadjustment. Complete performance check and adjustment instructions are given in Sections 4 and 5 of this manual.

5. Isolate Trouble to a Circuit

To isolate problems to a particular area, use any symptoms noticed to help locate the trouble. Refer to the troubleshooting charts in the Diagrams section as an aid in locating a faulty circuit.

6. Check Power Supplies

When trouble symptoms appear in more than one circuit, first check the power supplies; then check the affected circuits by taking voltage and waveform readings. Check first for the correct output voltage of each individual supply. These voltages are measured between the power supply test points and ground (see the associated circuit board illustration and Table 6-5).

Voltage levels may be measured either with a DMM or with an oscilloscope. Voltage ripple amplitudes must be measured using an oscilloscope. Before checking power-supply circuitry, set the INTENSITY control to normal brightness, the SEC/DIV switch to 0.1 ms, the Trigger MODE to P-P AUTO, and the Vertical MODE switch to CH 1.

When measuring ripple, use a 1X probe. The ripple values listed are based on a system limited in bandwidth to 30 kHz. Using a system with wider bandwidth will result in higher readings.

If the power-supply voltages and ripple are within the ranges listed in Table 6-4, the supply can be assumed to be working correctly. If they are outside the range, the supply may be either misadjusted or operating incorrectly. Use the Power Supply and CRT Display subsection in the Adjustment Procedure to adjust the -8.6-V supply.

A defective component elsewhere in the instrument can create the appearance of a power-supply problem and may also affect the operation of other circuits.

Table 6-4
Power Supply Voltage and Ripple Limits

Power Supply	Test Point	Reading (Volts)	P-P Ripple
-8.6 V ₁	W989	-8.56 to -8.64	5 mV
+5.0 V ₁	W991	+4.85 to +5.15	5 mV
+8.6 V ₁	W987	+8.34 to +8.86	5 mV
+102.0 V	W984	+98.9 to +105.0	20 mV
+205.0 V	W985	+198.8 to +211.1	50 mV
+22 V unreg	W752	Approx. +24 V	Approx. 1 V ^a

^aSet SEC/DIV switch to X-Y.

7. Check Circuit Board Interconnections

After the trouble has been isolated to a particular circuit, again check for loose or broken connections, improperly seated semiconductors, and heat-damaged components.

8. Check Voltages and Waveforms

Often the defective component can be located by checking circuit voltages or waveforms. Typical voltages are listed on the schematic diagrams. Waveforms indicated on the schematic diagrams by hexagonal-outlined numbers are shown adjacent to the diagrams. Waveform test points are shown on the circuit board illustrations.

NOTE

Voltages and waveforms indicated on the schematic diagrams are not absolute and may vary slightly between instruments. To establish operating conditions similar to those used to obtain these readings, see the Voltage and Waveform Setup Conditions preceding the waveform illustrations in the Diagrams section. Note the recommended test equipment, front-panel control settings, voltage and waveform conditions, and cable-connection instructions. Any special control settings required to obtain a given waveform are noted under the waveform illustration. Changes to the control settings from the initial setup, other than those noted, are not required.

9. Check Individual Components

WARNING

To avoid electric shock, always disconnect the instrument from the ac power source before removing or replacing components.

The following procedures describe methods of checking individual components. Two-lead components that are soldered in place are most accurately checked by first disconnecting one end from the circuit board. This isolates the measurement from the effects of the surrounding circuitry.

See Figure 9-1 for component value identification and Figure 9-2 for semiconductor lead configurations.

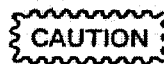

When checking semiconductors, observe the static-sensitivity precautions located at the beginning of this section.

TRANSISTORS. A good check of a transistor is actual performance under operating conditions. A transistor can most effectively be checked by substituting a known-good component. However, be sure that circuit conditions are not such that a replacement transistor might also be damaged. If substitute transistors are not available, use a dynamic-type transistor checker for testing. Static-type transistor checkers are not recommended, since they do not check operation under simulated operating conditions.

When troubleshooting transistors in the circuit with a voltmeter, measure both the emitter-to-base and emitter-to-collector voltages to determine whether they are consistent with normal circuit voltages. Voltages across a transistor may vary with the type of device and its circuit function.

Some of these voltages are predictable. The emitter-to-base voltage for a conducting silicon transistor will normally range from 0.6 V to 0.8 V. The emitter-to-collector voltage for a saturated transistor is about 0.2 V. Because these values are small, the best way to check them is by connecting a sensitive voltmeter across the junction rather than comparing two voltages taken with respect to ground. If the former method is used, both leads of the voltmeter must be isolated from ground.

If voltage values measured are less than those just given, either the device is shorted or no current is flowing in the external circuit. If values exceed the emitter-to-base values given, either the junction is reverse biased or the device is defective. Voltages exceeding those given for typical emitter-to-collector values could indicate either a nonsaturated device operating normally or a defective (open-circuited) transistor. If the device is conducting, voltage will be developed across the resistors in series with it; if open, no voltage will be developed across the resistors unless current is being supplied by a parallel path.

CAUTION

When checking emitter-to-base junctions, do not use an ohmmeter range that has a high internal current. High current may damage the transistor. Reverse biasing the emitter-to-base junction with a high current may degrade the current-transfer ratio (Beta) of the transistor.

A transistor emitter-to-base junction also can be checked for an open or shorted condition by measuring the resistance between terminals with an ohmmeter set to a range having a low internal source current, such as the R X 1-k Ω range. The junction resistance should be very high in one direction and much lower when the meter leads are reversed.

When troubleshooting a field-effect transistor (FET), the voltage across its elements can be checked in the same manner as previously described for other transistors. However, remember that in the normal depletion mode of operation, the gate-to-source junction is reverse biased; in the enhanced mode, the junction is forward biased.

INTEGRATED CIRCUITS. An integrated circuit (IC) can be checked with a voltmeter, test oscilloscope, or by direct substitution. A good understanding of circuit operation is essential when troubleshooting a circuit having IC components. Use care when checking voltages and waveforms around the IC so that adjacent leads are not shorted together. An IC test clip provides a convenient means of clipping a test probe to an IC.

CAUTION

When checking a diode, do not use an ohmmeter scale that has a high internal current. High current may damage a diode. Checks on diodes can be performed in much the same manner as those on transistor emitter-to-base junctions.

DIODES. A diode can be checked for either an open or a shorted condition by measuring the

resistance between terminals with an ohmmeter set to a range having a low internal source current, such as the R X 1-k Ω range. The diode resistance should be very high in one direction and much lower when the meter leads are reversed.

Silicon diodes should have 0.6 V to 0.8 V across their junctions when conducting; Schottky diodes about 0.2 V to 0.4 V. Higher readings indicate that they are either reverse biased or defective, depending on polarity.

RESISTORS. Check resistors with an ohmmeter. Refer to the Replaceable Electrical Parts list for the tolerances of resistors used in this instrument. A resistor normally does not require replacement unless its measured value varies widely from its specified value and tolerance.

INDUCTORS. Check for open inductors by checking continuity with an ohmmeter. Shorted or partially shorted inductors can usually be found by checking the waveform response when high-frequency signals are passed through the circuit.

CAPACITORS. A leaky or shorted capacitor can best be detected by checking resistance with an ohmmeter set to one of the highest ranges. Do not exceed the voltage rating of the capacitor. The resistance reading should be high after the capacitor is charged to the output voltage of the ohmmeter. An open capacitor can be detected with a capacitance meter or by checking whether the capacitor passes ac signals.

10. Repair and Adjust the Circuit

If any defective parts are located, follow the replacement procedures given under Corrective Maintenance in this section. After any electrical component has been replaced, the performance of that circuit and any other closely related circuit should be checked. Since the power supplies affect all circuits, performance of the entire instrument should be checked if work has been done on the power supplies or if the power transformer has been replaced. Readjustment of the affected circuitry may be necessary. Refer to the Performance Check Procedure and Adjustment Procedure, Sections 4 and 5 of this manual and to Table 5-1 (Adjustments Affected by Repairs).

CORRECTIVE MAINTENANCE

INTRODUCTION

Corrective maintenance consists of component replacement and instrument repair. This part of the manual describes special techniques and procedures required to replace components in this instrument. If it is necessary to ship your instrument to a Tektronix Service Center for repair or service, refer to the repackaging information in Section 2 of this manual.

MAINTENANCE PRECAUTIONS

To reduce the possibility of personal injury or instrument damage, observe the following precautions.

1. Disconnect the instrument from the ac-power source before removing or installing components.
2. Verify that the line-rectifier filter capacitors are discharged prior to performing any servicing.
3. Use care not to interconnect instrument grounds which may be at different potentials (cross grounding).
4. When soldering on circuit boards or small insulated wires, use only a 15-watt, pencil-type soldering iron.

OBTAINING REPLACEMENT PARTS

Most electrical and mechanical parts can be obtained through your local Tektronix Field Office or representative. However, many of the standard electronic components can usually be obtained from a local commercial source. Before purchasing or ordering a part from a source other than Tektronix, Inc., please check the Replaceable Electrical Parts list for the proper value, rating, tolerance, and description.

NOTE

Physical size and shape of a component may affect instrument performance, particularly at high frequencies. Always use direct-replacement components, unless it is known that a substitute will not degrade instrument performance.

Special Parts

In addition to the standard electronic components, some special parts are used in the instrument. These components are manufactured or selected by Tektronix, Inc., to meet specific performance requirements, or are manufactured for Tektronix, Inc., in accordance with our specifications. The various manufacturers can be identified by referring to the Cross Index—Manufacturer's Code number to Manufacturer at the beginning of the Replaceable Electrical Parts list. Most of the mechanical parts used in this instrument were manufactured by Tektronix, Inc. Order all special parts directly from your local Tektronix Field Office or representative.

Ordering Parts

When ordering replacement parts from Tektronix, Inc., be sure to include all of the following information:

1. Instrument type (include all modification and option numbers).
2. Instrument serial number.
3. A description of the part (if electrical, include its full circuit component number).
4. Tektronix part number.

MAINTENANCE AIDS

The maintenance aids listed in Table 6-5 include items required for performing most of the maintenance procedures in this instrument. Equivalent products may be substituted for those given, provided their characteristics are similar.

Table 6-5
Maintenance Aids

Description	Specification	Usage	Example
1. Soldering Iron	15 to 25 W.	General soldering and unsoldering.	Antex Precision Model C.
2. Torx Screwdriver	Torx tips #T9 and #T15.	Assembly and disassembly.	Tektronix p/n #T9 003-0965-00 #T15 003-0966-00.
3. Nutdrivers	1/4 inch, 7/16 inch, and 1/2 inch.	Assembly and disassembly.	Xcelite #8, #10, #14, and #16.
4. Open-end Wrench	5/16 inch and 1/2 inch.	Channel Input, EXT BNC connectors and Transformer.	
5. Hex Wrenches	1/16 inch.	Assembly and disassembly.	Allen wrenches.
6. Long-nose Pliers		Component removal and replacement.	
7. Diagonal Cutters		Component removal and replacement.	
8. Vacuum Solder Extractor	No Static Charge Retention.	Unsoldering components.	Pace Model PC-10.
9. 1X Probe		Power supply ripple check.	Tektronix P6101 Probe (X1), p/n 010-6101-03.
10. Lubricant	No-Noise. [®]	Switch lubrication.	Tektronix p/n 006-0442-02.

RIBBON-CABLE CONNECTIONS

Connections between circuit boards are accomplished with ribbon cables. One end of the ribbon cables is inserted into the multipin connector while the other end is soldered to the circuit board. The ribbon cable to the multipin connector can be removed or installed by pressing down on the release bar of the connector as shown in Figure 6-1. To remove the ribbon cable, pull it straight out from the connector; to install the ribbon cable, insert the bare wires up to the insulation into the connector. Remove pressure from the release bare, the ribbon cable will be lock firmly into the connector.

To provide correct orientation of a cable, a number "1" is stamped on the circuit board and on top of the multipin connector. The index wire of the ribbon is striped a different color than the rest of the cable. Align the index wire with the pin 1 indicator when reinserting the ribbon cable into its connector. Ensure the ribbon cable is evenly trimmed and 5 mm of wire (about 1/4 inch) is exposed for correct insertion into the connector.

If any individual wire in the cable is faulty, the entire ribbon cable should be replaced. When unsoldering the ribbon cable from the circuit board, note the location of the ribbon cable for reinstallation purposes. Align the index wire with the square pad on the circuit board.

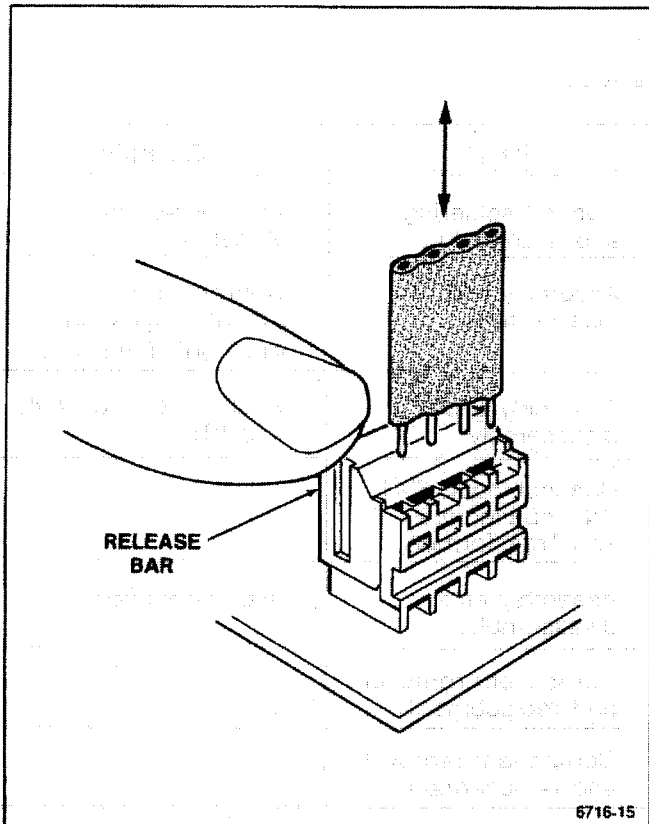

Figure 6-1. Multi-connector holder orientation.

TRANSISTORS AND INTEGRATED CIRCUITS

Transistors and integrated circuits should not be replaced unless they are actually defective. If removed from their sockets or unsoldered from the circuit board during routine maintenance, return them to their original circuit board locations. Unnecessary replacement or transposing of semiconductor devices may affect the adjustment of the instrument. When a semiconductor is replaced, check the performance of any circuit that may be affected.

Any replacement component should be of the original type or a direct replacement. Bend transistor leads to fit their circuit board holes, and cut the leads to the same length as the original component. See Figure 9-2 in the Diagrams section for lead-configuration illustrations.

Power-supply transistors Q933, Q942, and Q946 are insulated from the chassis by a heat-transferring pad and insulation bushing. Reinstall the pad and bushing when replacing this transistor.

NOTE

After replacing a power transistor, check that the collector is not shorted to the chassis before applying power to the instrument.

To remove socketed, dual-in-line-packaged (DIP) integrated circuits, pull slowly and evenly on both ends of the device. Avoid disengaging one end of the integrated circuit from the socket before the other, since this may damage the pins.

To remove a soldered DIP IC when it is going to be replaced, clip all the leads of the device and remove the leads from the circuit board one at a time. If the device must be removed intact for possible reinstallation, do not heat adjacent conductors consecutively. Apply heat to pins at alternate sides and ends of the IC as solder is removed. Allow a moment for the circuit board to cool before proceeding to the next pin.

SOLDERING TECHNIQUES

The reliability and accuracy of this instrument can be maintained only if proper soldering techniques are used to remove or replace parts. General soldering techniques, which apply to maintenance of any precision electronic equipment, should be used when working on this instrument.

WARNING

To avoid an electric-shock hazard, observe the following precautions before attempting any soldering: turn the instrument off, disconnect it from the ac power source, and wait at least three minutes for the line-rectifier filter capacitors to discharge.

Use rosin-core wire solder containing 63% tin and 37% lead. Contact your local Tektronix Field Office or representative to obtain the names of approved solder types.

When soldering on circuit boards or small insulated wires, use only a 15-watt, pencil-type soldering iron. A higher wattage soldering iron may cause etched-circuit conductors to separate from the circuit board base material and melt the insulation on small wires. Always keep the soldering-iron tip properly tinned to ensure best heat transfer from the iron tip to the solder joint. Apply only enough solder to make a firm joint. After soldering, clean the area around the solder connection with an approved flux-removing solvent (such as isopropyl alcohol) and allow it to air dry.

Attempts to unsolder, remove, and resolder leads from the component side of a circuit board may cause damage to the reverse side of the circuit board.

The following techniques should be used to replace a component on a circuit board:

1. Touch the vacuum desoldering tool to the lead at the solder connection. Never place the iron directly on the circuit board; doing so may damage the circuit board.

NOTE

Some components are difficult to remove from the circuit board due to a bend placed in the component leads during machine insertion. To make removal of machine-inserted components easier, straighten the component leads on the reverse side of the circuit board.

2. When removing a multipin component, especially an IC, do not heat adjacent pins consecutively. Apply heat to the pins at alternate sides and ends of the IC as solder is removed. Allow a moment for the circuit board to cool before proceeding to the next pin.

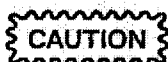

Excessive heat can cause the etched-circuit conductors to separate from the circuit board. Never allow the solder extractor tip to remain at one place on the circuit board for more than three seconds. Damage caused by poor soldering techniques can void the instrument warranty.

3. Bend the leads of the replacement component to fit the holes in the circuit board. If the component is replaced while the circuit board is installed in the instrument, cut the leads so they protrude only a small amount through the reverse side of the circuit board. Excess lead length may cause shorting to other conductive parts.

4. Insert the leads into the holes of the circuit board so that the replacement component is positioned the same as the original component. Most components should be firmly seated against the circuit board.

5. Touch the soldering iron to the connection and apply enough solder to make a firm solder joint.

Do not move the component while the solder hardens.

6. Cut off any excess lead protruding through the circuit board (if not clipped to the correct length in step 3).

7. Clean the area around the solder connection with an approved flux-removing solvent. Be careful not to remove any of the printed information from the circuit board.

REMOVAL AND REPLACEMENT INSTRUCTIONS

The exploded view drawings in the Replaceable Mechanical Parts list (Section 10) may be helpful during the removal and reinstallation of individual subassemblies or components. Circuit board and component locations are shown in the Diagrams section.

Cabinet

WARNING

To avoid electric shock, disconnect the instrument from the ac-power-input source before removing or replacing any component or assembly.

To remove the instrument cabinet, perform the following steps:

1. Disconnect the power cord from the instrument. For instruments with a power-cord securing clamp, remove the Phillips-head screw holding the power-cord securing clamp before disconnecting the power cord.

2. Remove two screws and the two power cord retainers from the rear panel (located on each side). Remove the rear panel.

3. Remove two screws from the rear panel (located on each side) and remove it from the instrument.

4. Remove four screws, one from the left-rear side and three from the right-rear side of the cabinet.

5. Use one hand to rise the center rear of the cabinet until the tab clears the slot in the rear chassis. With the other hand, push the instrument chassis forward until it clears the cabinet tab.

6. Pull the front panel and attached chassis forward and out of the cabinet.

7. To reinstall the cabinet, perform the reverse of the preceding steps. Ensure that the cabinet tab is inserted in the rear-chassis slot, and the cabinet is flush with the rear of the chassis.

8. Reinstall the rear panel. Ensure the rear chassis tabs are inserted into the slots in the rear panel properly (slots are located just above the bottom rear feet), and the screw holes in the rear chassis and rear panel are properly aligned.

9. Reconnect the power cord and power-cord securing clamp (if removed in step 1).

Cathode-Ray Tube

WARNING

Use care when handling a crt. Breakage of the crt may cause high-velocity scattering of glass fragments (implosion). Protective clothing and safety glasses should be worn. Avoid striking the crt on any object which may cause it to crack or implode. When storing a crt, either place it in a protective carton or set it face down on a smooth surface in a protected location with a soft mat under the faceplate.

The crt can be removed and reinstalled as follows:

1. Unsolder the Trace Rotation wires (J987) from the Front-Panel circuit board (note the connection locations and wire colors for reinstallation reference).

2. Remove two front-panel screws that retain the plastic crt frame and light filter to the front panel. Remove the crt frame and light filter from the instrument.

3. With the rear of the instrument facing you, place the fingers of both hands over the front edge of the front subpanel. Then, using both thumbs, press forward gently on the crt funnel near the front of the crt. When the crt base pins disengage from the socket, remove the crt and the crt shield through the instrument front panel. Place the crt in a safe place until it is reinstalled. If the plastic crt corner pads fall out, save them for reinstallation.

NOTE

When installing the crt into the instrument, reinstall any loose plastic crt corner pads that are out of place. Ensure all crt pins are straight and that the indexing keys on the crt base, socket, and shield are aligned. Ensure that the ground clip from the crt support bracket makes contact only with the outside of the crt shield.

To reinstall the crt, perform the reverse of the preceding steps.

Power Transformer

The Power Transformer (T901) can be removed and reinstalled as follows:

1. Remove the top Power Supply shield by performing the following instructions.

a. Rotate the instrument until the rear chassis is facing you.

b. Using both hands, place the fingers underneath and the thumbs on top of the Power Supply shield.

c. Gently push the Power Supply shield towards the rear chassis and at the same time pull up on the shield until the tabs are clear of the slots in the inner-chassis.

d. Pull the Power Supply shield towards the front of the instrument with a slight upward tilt until the rear tabs are clear of the slots in the rear chassis.

2. Disconnect P902, a seven-wire connector from J902 on the Mains Input circuit board. Note the orientation of the connector for proper reinstallation.

3. Remove the four nuts and lock washers from the Power Transformer (inside the instrument) without removing the support screws (supporting the transformer) from the rear panel. Note the physical orientation of the Power Transformer.

4. Supporting the Transformer with one hand, pull the four screws out until the transformer is free (leaving the screws inside of the supports). Remove the transformer and the four screws and supports from the instrument.

To reinstall the Power Transformer, perform the reverse of the preceding steps.

Mains Input Circuit Board

The Mains Input circuit board can be removed and reinstalled as follows:

1. Perform steps 1 and 2 of the Power Transformer procedure.
2. Unsolder W903, a three wire ribbon from Mains Input circuit board.
3. Remove the POWER knob shaft by inserting a scribe (or similar tool) in the notch between the end of the knob shaft and the end of the Power switch shaft and gently pry the connection apart. Pull the POWER knob shaft out through the front panel.
4. Remove the two screws and nuts that secure the power cord receptacle to the rear chassis.
5. Remove the grounding screw and nut (top corner) that secure the Mains Input circuit board to the inner chassis.
6. Pull the Mains Input circuit board and attached shield towards the inner chassis and up out of the instrument.

To reinstall the Mains Input circuit board, perform the reverse of the preceding steps.

Timebase/Attenuator Circuit Board Assembly

The Timebase/Attenuator circuit board assembly can be removed and reinstalled as follows:

1. Place the instrument on its side (CRT down) and unsolder the following wire straps and resistors, noting their locations for reinstallation reference:
 - a. Unsolder the two resistors from the CH 1 VOLTS/DIV and CH 2 VOLTS/DIV switches to the Front-Panel circuit board.
 - b. Unsolder the wire strap to the CH 1 OR X connector ground lug from the Timebase/Attenuator circuit board wire strap.
 - c. Unsolder the wire strap to the CH 2 OR Y connector ground lug from the Timebase/Attenuator circuit board wire strap.
 - d. Unsolder and pull the two wire straps from the Front-Panel circuit board that comes from the Attenuator circuit board.

2. Place the instrument down (normal position) and use a 1/16-inch hex wrench to loosen the set screws on the CH 1 VOLTS/DIV, CH 2 VOLTS/DIV, and SEC/DIV Variable knobs.

3. Remove CH 1 VOLTS/DIV, CH 2 VOLTS/DIV, and SEC/DIV Variable knobs and switch knobs from the instrument.

4. Disconnect the following cables from the Timebase/Attenuator circuit board assembly, noting their locations for reinstallation reference:

- a. J90, a six-wire cable located at the rear edge of the circuit board.
- b. J755, a four-wire cable located at the rear right-hand corner of the circuit board.
- c. J30, a four-wire cable located to the left of the CH 1 attenuator switch.
- d. J80, a four-wire cable located between the CH 1 and CH 2 attenuator switches.
- e. J7, a six-wire cable located between the CH 2 attenuator switch and the SEC/DIV switch.
- f. J701, a six-wire cable located at the front right-hand corner of the circuit board.

5. Remove the following three screws that secure the Timebase/Attenuator circuit board to the post spacers.

- a. One screw from the right-rear corner of the Timebase/Attenuator circuit board assembly.
- b. Two screws from the extreme left side of the Timebase/Attenuator circuit board assembly.

6. Remove the Focus knob shaft by pulling the shaft with one hand towards the front while holding the Focus pot shaft with the other hand.

7. Pull the Timebase/Attenuator circuit assembly board straight back from the front of the instrument until the attenuator switches are clear of the Front-Panel circuit board. Then lift out the entire assembly through the top of the instrument.

NOTE

If accessibility to the bottom of the Timebase/Attenuator circuit board is desired perform steps 8 through 10.

8. Remove one screw from the center front bottom of the attenuator shield.

9. Remove two screws from the front corners of the Timebase/Attenuator circuit board and two nuts from the front corners of the attenuator shield.

10. Remove the attenuator shield by pulling it back until the shield tab clears the Timebase/Attenuator ground bracket.

To reinstall the Timebase/Attenuator circuit board assembly, perform the reverse of the preceding steps.

Front-Panel Circuit Board

The Front-Panel circuit board can be removed and reinstalled as follows:

1. Perform the Timebase/Attenuator circuit board assembly removal procedure.

2. Remove the knobs from the following control shafts by pulling them straight out from the front panel:

- a. INTENSITY.
- b. Channel 1 and Channel 2 POSITION.
- c. Horizontal POSITION
- e. LEVEL.

3. Turn the instrument on its side (CRT down) and unsolder the following wire straps and resistors underneath the instrument, noting their locations for reinstallation reference:

a. Unsolder the two resistors and bare straps to the CH 1 OR X and CH 2 OR Y connectors and ground lugs from the Front-Panel circuit board.

b. Unsolder the resistor and ground strap to the EXT INPUT OR Z connector and ground lug from the Front-Panel circuit board.

4. Turn the instrument over again and unsolder the Trace Rotation wires (J987) from the Front-Panel circuit board (note the connection locations and wire colors for reinstallation reference).

5. Remove the Power Switch extension shaft by disengaging from power switch and pulling it out through the Front-Panel circuit board.

6. Disconnect the following six-wire cables from the front edge of Main circuit board, noting their locations for reinstallation reference: J1, J2, J3, J5, and J6.

7. Remove the five screws that secure the Front-Panel circuit board to the front chassis, noting their respective positions.

8. Remove the Front-Panel circuit board from the front chassis taking care not to lose the slider switch covers.

To reinstall the Front-Panel circuit board, perform the reverse of the preceding steps.

Main Circuit Board

All components on the Main circuit board are accessible either directly or by removing either the crt, Power Transformer or the Timebase/Attenuator circuit board assembly. Removal of the Main circuit board is required only when it is necessary to replace the circuit board with a new one.

The Main circuit board can be removed and reinstalled as follows:

1. Perform the Cathode-Ray Tube removal procedure.

2. Perform step 1 of the Power Transformer procedure.

3. Unsolder the three-wire cable from the FOCUS potentiometer. The FOCUS potentiometer is located on the rear of the inner chassis.

4. Unsolder W893 from the Main circuit board. The cable is connected to the Focus pot located on the rear of the inner chassis.

5. Unsolder W903, a three ribbon from the Mains Input circuit board.

6. Disconnect the following cables from the Timebase/Attenuator circuit board assembly, noting their locations for reinstallation reference:

a. J90, a six-wire cable located at the rear edge of the circuit board.

b. J755, a four-wire cable located at the rear right-hand corner of the circuit board.

c. J30, a four-wire cable located to the left of the CH 1 attenuator switch.

d. J80, a four-wire cable located between the CH 1 and CH 2 attenuator switches.

e. J7, a six-wire cable located between the CH 2 attenuator switch and the SEC/DIV switch.

f. J701, a six-wire cable located at the front right-hand corner of the circuit board.

7. Rotate the instrument until the rear chassis is facing you.

8. Remove the two screws (lower right corner) that secure the heat sink for the vertical output transistors to the rear chassis.

9. Remove the one screw (lower left corner) that secures the heat sink for the power supply transistors to the rear chassis.

10. Turn instrument upside down and rotate it until the front is facing you.

11. Unsolder the wire connected to the PROBE ADJUST terminal from the Main circuit board.

12. Remove the bottom power supply shield by inserting a narrow-blade screwdriver at each corner of the projecting edge and gently pry up until the two tabs are cleared of the slots in the Main circuit board. Pull and remove the shield out from underneath the rear chassis.

13. Remove four screws from the middle of the Main circuit board that secures the Timebase/Attenuator post spacers and inner chassis to the Main circuit board.

14. Remove three screws and two nuts that secure the Main circuit board and Timebase/Attenuator spacer post to the left side of the chassis frame.

15. Remove three screws and nuts that secure the Main circuit board to the right side of the chassis frame.

16. Pull the Main circuit board forward to clear the guides on the rear chassis.

NOTE

The front edge of the Main circuit board needs to be tilted out and away from the instrument to allow the removal of the ribbon cables.

17. Disconnect the following six-wire cables from the front edge of Main circuit board, noting their locations for reinstallation reference: J1, J2, J3, J5, and J6.

18. Lift the Main circuit board out of the instrument.

To reinstall the Main circuit board, perform the reverse of the preceding steps. Ensure that the Main circuit board is secure in the guides of the rear chassis.

Dear Mr. [Name],

I am writing to you regarding the [Topic].

[Text]

[Text]

[Text]

[Text]

[Text]

[Text]

[Text]

[Text]

[Text]

[Text]

[Text]

[Text]

[Text]

OPTIONS AND ACCESSORIES

This section contains a general description of options that can be included with the original instrument order. Options available at the time of manual publication are listed as follows:

Option 1C	Low Cost Camera
Option 1K	Instrument Cart
Option 1R	Rackmounting
Option 1T	Transit Case
Option 02	Front Panel Cover and Accessories Pouch
Option 22	24-1X Signal Adapters
Option 23	Two-10X Standard P6103 Probes
Option 24	Two-1X to 10X P6062B Selectable-Attenuation Probes
Options A1-A5	International Power Cords

To obtain any of these options or other accessories after the instrument has been received, refer to Tables 7-1 (Power Cords and Fuses) and Tables 7-2 (Optional Accessories), in this section. For additional information about instrument options and other optional accessories, consult the current Tektronix Product Catalog or contact your local Tektronix Sales Office or distributor.

OPTION 1C

When Option 1C is specified, a Tektronix C-5c Option 04 low-cost camera is included in the shipment. The camera is useful for capturing single events and documenting measurement results.

OPTION 1K

When Option 1K is specified, a K212 Portable Instrument Cart is included in the shipment. The cart provides a stable, movable platform that is well suited for on-site instrument mobility.

OPTION 1R

When the oscilloscope is ordered with Option 1R, it is shipped in a configuration that permits easy installation into virtually any 19-inch wide electronic equipment rack. All hardware is supplied for mounting the instrument into the main frame.

Complete rack mounting instructions are provided in a separate document. These instructions also contain the procedures for converting a standard instrument into the Option 1R configuration by using the separately orderable rack-mounting conversion kit.

OPTION 1T

When Option 1T is specified, a composite case of 24.5" X 16.5" X 11.5" that weighs 12 lbs. 6 oz. is included in the shipment. The composite case is useful as a reusable shipping container or a carry-on luggage container for the instrument.

OPTION 02

Option 02 is intended for users who need added front-panel protection and accessories-carrying ease. It includes a protective front panel cover and an accessories pouch that attaches to the top of the instrument.

OPTION 22

When Option 22 is specified, 24 1X Signal Adapters are included with the instrument. Each cable has one BNC Male connector on one end and two clip heads on the other end of the cable.

OPTION 23

When Option 23 is specified, two P6103 10X Probes are included with the instrument.

OPTION 24

When Option 24 is specified, two P6062B 1X to 10X Selectable-Attenuation Probes are included with the instrument.

**OPTIONS A1-A5
INTERNATIONAL POWER CORDS**

Instruments are shipped with the detachable power cord and fuse configuration ordered by the customer. Table 7-1 identifies the Tektronix part numbers for international power cords and associated fuses. Descriptive information about power cord options is provided in Section 1, Preparation for Use.

OPTIONAL ACCESSORIES

Table 7-2 lists recommended optional accessories for your instrument.

Table 7-1
International Power Cords and Fuses

Description	Part Number
Option A1 (Europe)	
Power Cord, 2.5 m	161-0104-06
Fuse, 0.5 A, 250 V, 3AG, 1/4" x 1 1/4", Slow	159-0032-00
Option A2 (United Kingdom)	
Power Cord, 2.5 m	161-0104-07
Fuse, 0.5 A, 250 V, 3AG, 1/4" x 1 1/4", Slow	159-0032-00
Option A3 (Australia)	
Power Cord, 2.5 m	161-0104-05
Fuse, 0.5 A, 250 V, 3AG, 1/4" x 1 1/4", Slow	159-0032-00
Option A4 (North America)	
Power Cord, 2.5 m	161-0104-08
Fuse, 0.5 A, 250 V, 3AG, 1/4" x 1 1/4", Slow	159-0032-00
Option A5 (Switzerland)	
Power Cord, 2.5 m	161-0167-00
Fuse, 0.5 A, 250 V, 3AG, 1/4" x 1 1/4", Slow	159-0032-00

Table 7-2
Optional Accessories

Description	Part Number
Front Panel Protective Cover	200-3397-00
Accessory Pouch	016-0677-02
Front Panel Protective Cover and Accessory Pouch	020-1514-00
Transit Case	016-0792-01
CRT Light Filter, Clear	337-2775-01
Rack Mount Conversion Kit	016-0819-00
Viewing Hoods	
Collapsible	016-0592-00
Polarised	016-0180-00
Binocular	016-0566-00
Probe, 10X, 2 m, with accessories	P6103
Alternative Power Cords	
Standard (United States)	161-0104-00
European	020-0859-00
United Kingdom	020-0860-00
Australian	020-0861-00
North American	020-0862-00
Swiss	020-0863-00
Attenuator Voltage Probes	
10X Standard	P6103
10X Subminiature	P6130
1X-10X Environmental	P6008
1X-10X Selectable	P6062B
100X High Voltage	P6009
1000X High Voltage	P6015
Current Probes	P6021, P6022, A6302/AM503, A6303/AM503
Current-Probe Amplifier	134
Probe 10X, FET	P6202A
Active-probe Power Supply	1101A
Ground Isolation Monitor	A6901
Isolator (for multiple, independently referenced, differential measurements)	A6902B
DC Inverter	1107
DC Inverter Mounting Kit	016-0785-00

Table 7-2 (cont)

Description	Part Number
Portable Power Supply	1105
Battery Pack	1106
Oscilloscope Cameras	
Low-cost	C-5C Option 04
Motorized	C-7 Option 03 and Option 30
Portable Instrument Cart	K212
2205 Service Manual	070-6716-00

STANDARD ACCESSORIES

Each instrument is shipped with the following standard accessories.

Quantity	Description	Part Number
2	1X Signal Adapters	103-0275-00
1	Operator's Manual	070-6717-00
1	Standard (United States) Power Cord, 2.5 m	161-0230-01
1	Fuse, 0.75 A, 25 V, 3AG, 1/4" x 1 1/4", slow	159-0042-00
1	Fuse, 0.5 A, 250 V, 3AG, 1/4" x 1 1/4", slow	159-0032-00
	For optional power cord and fuse see Table 7-1	
1	Power Cord Clamp	343-0003-00
1	Screw, 6-32	211-0721-00
1	Washer	210-0803-00

REPLACEABLE ELECTRICAL PARTS

PARTS ORDERING INFORMATION

Replacement parts are available from or through your local Tektronix, Inc. Field Office or representative.

Changes to Tektronix instruments are sometimes made to accommodate improved components as they become available, and to give you the benefit of the latest circuit improvements developed in our engineering department. It is therefore important, when ordering parts, to include the following information in your order: Part number, instrument type or number, serial number, and modification number if applicable.

If a part you have ordered has been replaced with a new or improved part, your local Tektronix, Inc. Field Office or representative will contact you concerning any change in part number.

Change information, if any, is located at the rear of this manual.

LIST OF ASSEMBLIES

A list of assemblies can be found at the beginning of the Electrical Parts List. The assemblies are listed in numerical order. When the complete component number of a part is known, this list will identify the assembly in which the part is located.

CROSS INDEX-MFR. CODE NUMBER TO MANUFACTURER

The Mfr. Code Number to Manufacturer index for the Electrical Parts List is located immediately after this page. The Cross Index provides codes, names and addresses of manufacturers of components listed in the Electrical Parts List.

ABBREVIATIONS

Abbreviations conform to American National Standard Y1.1

COMPONENT NUMBER (column one of the Electrical Parts List)

A numbering method has been used to identify assemblies, subassemblies and parts. Examples of this numbering method and typical expansions are illustrated by the following:

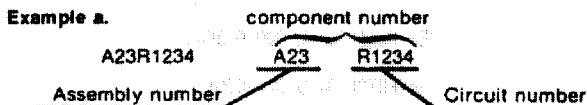

Read: Resistor 1234 of Assembly 23

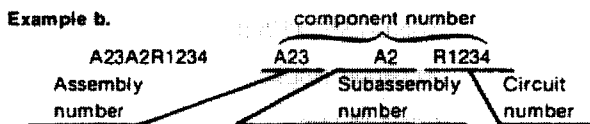

Read: Resistor 1234 of Subassembly 2 of Assembly 23

Only the circuit number will appear on the diagrams and circuit board illustrations. Each diagram and circuit board illustration is clearly marked with the assembly number. Assembly numbers are also marked on the mechanical exploded views located in the Mechanical Parts List. The component number is obtained by adding the assembly number prefix to the circuit number.

The Electrical Parts List is divided and arranged by assemblies in numerical sequence (e.g., assembly A1 with its subassemblies and parts, precedes assembly A2 with its subassemblies and parts).

Chassis-mounted parts have no assembly number prefix and are located at the end of the Electrical Parts List.

TEKTRONIX PART NO. (column two of the Electrical Parts List)

Indicates part number to be used when ordering replacement part from Tektronix.

SERIAL/MODEL NO. (columns three and four of the Electrical Parts List)

Column three (3) indicates the serial number at which the part was first used. Column four (4) indicates the serial number at which the part was removed. No serial number entered indicates part is good for all serial numbers.

NAME & DESCRIPTION (column five of the Electrical Parts List)

In the Parts List, an Item Name is separated from the description by a colon (:). Because of space limitations, an Item Name may sometimes appear as incomplete. For further Item Name identification, the U. S. Federal Cataloging Handbook H6-1 can be utilized where possible.

MFR. CODE (column six of the Electrical Parts List)

Indicates the code number of the actual manufacturer of the part. (Code to name and address cross reference can be found immediately after this page.)

MFR. PART NUMBER (column seven of the Electrical Parts List)

Indicates actual manufacturers part number.

CROSS INDEX - MFR. CODE NUMBER TO MANUFACTURER

Mfr. Code	Manufacturer	Address	City, State, Zip Code
00213	NYTRONICS COMPONENTS GROUP INC SUBSIDIARY OF NYTRONICS INC	ORANGE ST	DARLINGTON SC 29532
00853	SANGAMO WESTON INC COMPONENTS DIV	SANGAMO RD PO BOX 128	PICKENS SC 29671-9716
01121	ALLEN-BRADLEY CO	1201 S 2ND ST	MILWAUKEE WI 53204-2410
01295	TEXAS INSTRUMENTS INC SEMICONDUCTOR GROUP	13500 N CENTRAL EXPY PO BOX 655012	DALLAS TX 75265
02735	RCA CORP SOLID STATE DIVISION	ROUTE 202	SOMERVILLE NJ 08876
03508	GENERAL ELECTRIC CO SEMI-CONDUCTOR PRODUCTS DEPT	W GENESEE ST	AUBURN NY 13021
04222	AVX CERAMICS DIV OF AVX CORP	19TH AVE SOUTH P O BOX 867	MYRTLE BEACH SC 29577
04426	ITW SWITCHES DIV OF ILLINOIS TOOL WORKS INC	6615 W IRVING PARK RD	CHICAGO IL 60634-2410
04713	MOTOROLA INC SEMICONDUCTOR PRODUCTS SECTOR	5005 E MCDOWELL RD	PHOENIX AZ 85008-4229
05397	UNION CARBIDE CORP MATERIALS SYSTEMS DIV	11901 MADISON AVE	CLEVELAND OH 44101
05828	GENERAL INSTRUMENT CORP GOVERNMENT SYSTEMS DIV	600 W JOHN ST	HICKSVILLE NY 11802
07716	TRW INC TRW IRC FIXED RESISTORS/BURLINGTON	2850 MT PLEASANT AVE	BURLINGTON IA 52601
13511	AMPHENOL CADRE DIV BUNKER RAMO CORP		LOS GATOS CA
14193	CAL-R INC	1601 OLYMPIC BLVD PO BOX 1397	SANTA MONICA CA 90406
14752	ELECTRO CUBE INC	1710 S DEL MAR AVE	SAN GABRIEL CA 91776-3825
19396	ILLINOIS TOOL WORKS INC PAKTRON DIV	1205 MCCONVILLE RD PO BOX 4539	LYNCHBURG VA 24502-4535
19701	MEPCO/CENTRALAB A NORTH AMERICAN PHILIPS CO MINERAL WELLS AIRPORT	PO BOX 760	MINERAL WELLS TX 76067-0760
24546	CORNING GLASS WORKS	550 HIGH ST	BRADFORD PA 16701-3737
31918	ITT SCHADOW INC	8081 WALLACE RD	EDEN PRAIRIE MN 55344-2224
32997	BOURNS INC TRIMPOT DIV	1200 COLUMBIA AVE	RIVERSIDE CA 92507-2114
34899	FAIR-RITE PRODUCTS CORP	1 COMMERCIAL ROW	WALLKILL NY 12589
51406	MURATA ERIE NORTH AMERICA INC HEADQUARTERS AND GEORGIA OPERATIONS	2200 LAKE PARK DR	SMYRNA GA 30080
52769	SPRAGUE-GOODMAN ELECTRONICS INC	134 FULTON AVE	GARDEN CITY PARK NY 11040-5352
54583	TDK ELECTRONICS CORP	12 HARBOR PARK DR	PORT WASHINGTON NY 11550
55680	NICHICON /AMERICA/ CORP	927 E STATE PKY	SCHAUMBURG IL 60195-4526
56289	SPRAGUE ELECTRIC CO WORLD HEADQUARTERS	92 HAYDEN AVE	LEXINGTON MA 02173-7929
57668	ROHM CORP	8 WHATNEY PO BOX 19515	IRVINE CA 92713
59660	TUSONIX INC	7741 N BUSINESS PARK DR PO BOX 37144	TUCSON AZ 85740-7144
75042	IRC ELECTRONIC COMPONENTS PHILADELPHIA DIV	401 N BROAD ST	PHILADELPHIA PA 19108-1001
75915	TRW FIXED RESISTORS LITTELFUSE INC	800 E NORTHWEST HWY	DES PLAINES IL 60016-3049
80009	SUB TRACOR INC TEKTRONIX INC	14150 SW KARL BRAUN DR PO BOX 500	BEAVERTON OR 97077-0001
83003	VARO INC	2203 W WALNUT ST PO BOX 401426	GARLAND TX 75042
91637	DALE ELECTRONICS INC	2064 12TH AVE PO BOX 609	COLUMBUS NE 68601-3632
D5243	ROEDERSTEIN E SPEZIALFABRIK FUER KONDENSATOREN GMBH	LUDMILLASTRASSE 23-25	8300 LANDSHUT GERMANY
K0491	SEAELECTRO LTD	WALTON ROAD FARLINGTON	PORTSMOUTH ENGLAND
K5856	RCA LTD BEECH HOUSE	373-399 LONDON ROAD CAMBERLEY	SURREY ENGLAND

CROSS INDEX - MFR. CODE NUMBER TO MANUFACTURER

Mfr. Code	Manufacturer	Address	City, State, Zip Code
K7779	SIEMENS LTD SIEMENS HOUSE	WINDMILL ROAD SUNBURY-ON-THAMES	MIDDLESEX TW16 7HS ENGLAND
K8788	PIHER INTERNATIONAL LTD	HORTON ROAD WEST DRAYTON	MIDDLESEX ENGLAND
K8996	MULLARD LIMITED	MULLARD HOUSE TORRINGTON PLACE 34 BOWATER ROAD	LONDON WC1 7 HD ENGLAND
TK00A	G ENGLISH ELECTRONICS LTD		LONDON SE18 5TF ENGLAND
TK0213	TOPTRON CORP		TOKYO JAPAN
TK0515	ERICSSON COMPONENTS INC	403 INTERNATIONAL PKY PO BOX 853904	RICHARDSON TX 75085-3904
TK0900	UNITED CHEMI-CON INC	9801 W HIGGINS SUITE 430	ROSEMONT IL 60018-4704
TKODY	A F BULGIN & CO LTD	BYE PASS ROAD BARKING	ESSEX ENGLAND
TK0EA	ARMON ELECTRONICS HERON HOUSE	109 WEMBLEY HILL ROAD WEMBLEY	MIDDX ENGLAND
TK0ED	COMPONENTS BUREAU UNIT 4	135 DITTON WAY	CAMBRIDGE ENGLAND
TK0EM	MOLEX ELECTRONICS MOLEX HOUSE	FARNHAM ROAD BORDON	HAMPSHIRE ENGLAND
TK1450	TOKYO COSMOS ELECTRIC CO LTD	2-268 SOBUDAI ZAWA	KANAGAWA 228 JAPAN
TK1727	PHILIPS NEDERLAND BV AFD ELONCO	POSTBUS 90050	5600 PB EINDHOVEN THE NETHERLANDS
TK1815	NOBLE - USA ELECTRONIC COMPONENTS GROUP	5450 METALBROOK INDUSTRIAL CT	ROLLING MEADOWS IL 60008
U3771	STANLER COMPONENTS BUSINESS CENTRE	HEY LANE	BRAINTREE ENGLAND

Replaceable Electrical Parts - 2205 Service

Component No.	Tektronix Part No.	Serial/Assembly No. Effective	Discont	Name & Description	Mfr. Code	Mfr. Part No.
A1	671-0425-00			CIRCUIT BD ASSY:MAIN	80009	671-0425-00
A2	671-0390-00			CIRCUIT BD ASSY:TIMEBASE/ATTEN	80009	671-0390-00
A3	671-0392-00			CIRCUIT BD ASSY:FRONT PANEL	80009	671-0392-00
A4	671-0391-00			CIRCUIT BD ASSY:MAIN INPUT	80009	671-0391-00

Component No.	Tektronix Part No.	Serial/Assembly No. Effective Date	Name & Description	Mfr. Code	Mfr. Part No.
A1	671-0425-00		CIRCUIT BD ASSY:MAIN	80009	671-0425-00
A1C114	281-0767-00		CAP, FXD, CER DI:330PF, 20%, 100V	04222	MA106C331MAA
A1C115	281-0767-00		CAP, FXD, CER DI:330PF, 20%, 100V	04222	MA106C331MAA
A1C116	281-0775-01		CAP, FXD, CER DI:0.1UF, 20%, 50V	04222	SA105E104MAA
A1C124	281-0775-01		CAP, FXD, CER DI:0.1UF, 20%, 50V	04222	SA105E104MAA
A1C125	281-0772-00		CAP, FXD, CER DI:4700PF, 10%, 100V	04222	MA201C472KAA
A1C126	283-0051-02		CAP, FXD, CER DI:0.0033UF, 5%, 100V	04222	SR211A332JAATR
A1C130	283-0108-00		CAP, FXD, CER DI:220PF, 10%, 200V	04222	SR152A221KAA
A1C133	281-0785-00		CAP, FXD, CER DI:68PF, 10%, 100V	04222	MA101A680KAA
A1C164	281-0767-00		CAP, FXD, CER DI:330PF, 20%, 100V	04222	MA106C331MAA
A1C165	281-0767-00		CAP, FXD, CER DI:330PF, 20%, 100V	04222	MA106C331MAA
A1C174	281-0775-01		CAP, FXD, CER DI:0.1UF, 20%, 50V	04222	SA105E104MAA
A1C175	281-0772-00		CAP, FXD, CER DI:4700PF, 10%, 100V	04222	MA201C472KAA
A1C176	283-0051-02		CAP, FXD, CER DI:0.0033UF, 5%, 100V	04222	SR211A332JAATR
A1C180	283-0108-00		CAP, FXD, CER DI:220PF, 10%, 200V	04222	SR152A221KAA
A1C198	290-0183-00		CAP, FXD, ELCTLT:1UF, 10%, 35V	05397	T3228105K035AS
A1C202	290-0183-00		CAP, FXD, ELCTLT:1UF, 10%, 35V	05397	T3228105K035AS
A1C215	281-0775-01		CAP, FXD, CER DI:0.1UF, 20%, 50V	04222	SA105E104MAA
A1C220	283-0057-00		CAP, FXD, CER DI:0.1UF, +80-20%, 200V	04222	SR306E104ZAA
A1C225	281-0812-00		CAP, FXD, CER DI:1000PF, 10%, 100V	04222	MA101C102KAA
A1C232	281-0771-00		CAP, FXD, CER DI:2200PF, 20%, 200V	04222	SA106E222MAA
A1C235	281-0771-00		CAP, FXD, CER DI:2200PF, 20%, 200V	04222	SA106E222MAA
A1C239	281-0771-00		CAP, FXD, CER DI:2200PF, 20%, 200V	04222	SA106E222MAA
A1C240	281-0771-00		CAP, FXD, CER DI:2200PF, 20%, 200V	04222	SA106E222MAA
A1C241	281-0205-00		CAP, VAR, PLASTIC:5.5-65 PF, 100V	TK1727	2222-808-32659
A1C242	281-0064-00		CAP, VAR, PLASTIC:0.25-1.5PF, 600V	52769	ER-530-013
A1C243	281-0064-00		CAP, VAR, PLASTIC:0.25-1.5PF, 600V	52769	ER-530-013
A1C245	281-0775-01		CAP, FXD, CER DI:0.1UF, 20%, 50V	04222	SA105E104MAA
A1C246	281-0775-01		CAP, FXD, CER DI:0.1UF, 20%, 50V	04222	SA105E104MAA
A1C247	281-0775-01		CAP, FXD, CER DI:0.1UF, 20%, 50V	04222	SA105E104MAA
A1C248	281-0775-01		CAP, FXD, CER DI:0.1UF, 20%, 50V	04222	SA105E104MAA
A1C320	290-0183-00		CAP, FXD, ELCTLT:1UF, 10%, 35V	05397	T3228105K035AS
A1C321	290-0183-00		CAP, FXD, ELCTLT:1UF, 10%, 35V	05397	T3228105K035AS
A1C322	290-0183-00		CAP, FXD, ELCTLT:1UF, 10%, 35V	05397	T3228105K035AS
A1C380	281-0775-01		CAP, FXD, CER DI:0.1UF, 20%, 50V	04222	SA105E104MAA
A1C381	281-0775-01		CAP, FXD, CER DI:0.1UF, 20%, 50V	04222	SA105E104MAA
A1C387	281-0775-01		CAP, FXD, CER DI:0.1UF, 20%, 50V	04222	SA105E104MAA
A1C389	281-0775-01		CAP, FXD, CER DI:0.1UF, 20%, 50V	04222	SA105E104MAA
A1C401	281-0775-01		CAP, FXD, CER DI:0.1UF, 20%, 50V	04222	SA105E104MAA
A1C402	290-0183-00		CAP, FXD, ELCTLT:1UF, 10%, 35V	05397	T3228105K035AS
A1C408	281-0775-01		CAP, FXD, CER DI:0.1UF, 20%, 50V	04222	SA105E104MAA
A1C418	290-1150-00		CAP, FXD, ELCTLT:15UF, +50%-10%, 16WVDC	K8996	030-25159
A1C431	290-1150-00		CAP, FXD, ELCTLT:15UF, +50%-10%, 16WVDC	K8996	030-25159
A1C480	281-0775-01		CAP, FXD, CER DI:0.1UF, 20%, 50V	04222	SA105E104MAA
A1C481	281-0775-01		CAP, FXD, CER DI:0.1UF, 20%, 50V	04222	SA105E104MAA
A1C489	281-0810-00		CAP, FXD, CER DI:5.6PF, +/-0.5PF, 100V	04222	MA101A5R6DAA
A1C490	281-0775-01		CAP, FXD, CER DI:0.1UF, 20%, 50V	04222	SA105E104MAA
A1C495	281-0773-00		CAP, FXD, CER DI:0.01UF, 10%, 100V	04222	MA201C103KAA
A1C496	281-0773-00		CAP, FXD, CER DI:0.01UF, 10%, 100V	04222	MA201C103KAA
A1C500	281-0775-01		CAP, FXD, CER DI:0.1UF, 20%, 50V	04222	SA105E104MAA
A1C501	281-0810-00		CAP, FXD, CER DI:5.6PF, +/-0.5PF, 100V	04222	MA101A5R6DAA
A1C503	281-0812-00		CAP, FXD, CER DI:1000PF, 10%, 100V	04222	MA101C102KAA
A1C505	281-0775-01		CAP, FXD, CER DI:0.1UF, 20%, 50V	04222	SA105E104MAA
A1C506	281-0767-00		CAP, FXD, CER DI:330PF, 20%, 100V	04222	MA106C331MAA
A1C520	281-0775-01		CAP, FXD, CER DI:0.1UF, 20%, 50V	04222	SA105E104MAA
A1C525	281-0758-00		CAP, FXD, CER DI:15PF, 20%, 100V	04222	SA102A150MAA
A1C530	281-0775-01		CAP, FXD, CER DI:0.1UF, 20%, 50V	04222	SA105E104MAA
A1C536	281-0814-00		CAP, FXD, CER DI:100 PF, 10%, 100V	04222	MA101A101KAA

Replaceable Electrical Parts - 2205 Service

Component No.	Tektronix Part No.	Serial/Assembly No. Effective Dscont	Name & Description	Mfr. Code	Mfr. Part No.
A1C537	281-0775-01		CAP,FXD,CER DI:0.1UF,20%,50V	04222	SA105E104MAA
A1C538	281-0812-00		CAP,FXD,CER DI:1000PF,10%,100V	04222	MA101C102KAA
A1C539	281-0812-00		CAP,FXD,CER DI:1000PF,10%,100V	04222	MA101C102KAA
A1C540	290-1153-00		CAP,FXD,ELCTLT:47UF,+50-10%,10V	K8996	030-24479
A1C545	283-0119-02		CAP,FXD,CER DI:2200PF,5%,200V	59660	855-402-Y5E0222J
A1C547	281-0767-00		CAP,FXD,CER DI:330PF,20%,100V	04222	MA106C331MAA
A1C550	281-0775-01		CAP,FXD,CER DI:0.1UF,20%,50V	04222	SA105E104MAA
A1C554	281-0812-00		CAP,FXD,CER DI:1000PF,10%,100V	04222	MA101C102KAA
A1C555	281-0775-01		CAP,FXD,CER DI:0.1UF,20%,50V	04222	SA105E104MAA
A1C560	281-0775-01		CAP,FXD,CER DI:0.1UF,20%,50V	04222	SA105E104MAA
A1C561	281-0812-00		CAP,FXD,CER DI:1000PF,10%,100V	04222	MA101C102KAA
A1C562	281-0775-01		CAP,FXD,CER DI:0.1UF,20%,50V	04222	SA105E104MAA
A1C570	281-0775-01		CAP,FXD,CER DI:0.1UF,20%,50V	04222	SA105E104MAA
A1C571	281-0785-00		CAP,FXD,CER DI:68PF,10%,100V	04222	MA101A680KAA
A1C572	281-0759-00		CAP,FXD,CER DI:15PF,20%,100V	04222	SA102A150MAA
A1C584	281-0775-01		CAP,FXD,CER DI:0.1UF,20%,50V	04222	SA105E104MAA
A1C587	281-0773-00		CAP,FXD,CER DI:0.01UF,10%,100V	04222	MA201C103KAA
A1C776	281-0775-01		CAP,FXD,CER DI:0.1UF,20%,50V	04222	SA105E104MAA
A1C780	281-0771-00		CAP,FXD,CER DI:2200PF,20%,200V	04222	SA106E222MAA
A1C782	281-0775-01		CAP,FXD,CER DI:0.1UF,20%,50V	04222	SA105E104MAA
A1C783	281-0064-00		CAP,VAR,PLASTIC:0.25-1.5PF,600V	52769	ER-530-013
A1C785	285-1101-00		CAP,FXD,PLASTIC:0.022UF,10%,200V	19396	223K02PT485
A1C789	281-0771-00		CAP,FXD,CER DI:2200PF,20%,200V	04222	SA106E222MAA
A1C794	281-0064-00		CAP,VAR,PLASTIC:0.25-1.5PF,600V	52769	ER-530-013
A1C795	285-1101-00		CAP,FXD,PLASTIC:0.022UF,10%,200V	19396	223K02PT485
A1C799	281-0771-00		CAP,FXD,CER DI:2200PF,20%,200V	04222	SA106E222MAA
A1C824	281-0785-00		CAP,FXD,CER DI:68PF,10%,100V	04222	MA101A680KAA
A1C828	281-0775-01		CAP,FXD,CER DI:0.1UF,20%,50V	04222	SA105E104MAA
A1C832	281-0775-01		CAP,FXD,CER DI:0.1UF,20%,50V	04222	SA105E104MAA
A1C834	281-0775-01		CAP,FXD,CER DI:0.1UF,20%,50V	04222	SA105E104MAA
A1C835	281-0775-01		CAP,FXD,CER DI:0.1UF,20%,50V	04222	SA105E104MAA
A1C845	281-0771-00		CAP,FXD,CER DI:2200PF,20%,200V	04222	SA106E222MAA
A1C847	283-0057-00		CAP,FXD,CER DI:0.1UF,+80-20%,200V	04222	SR306E104ZAA
A1C849	283-0057-00		CAP,FXD,CER DI:0.1UF,+80-20%,200V	04222	SR306E104ZAA
A1C851	283-0057-00		CAP,FXD,CER DI:0.1UF,+80-20%,200V	04222	SR306E104ZAA
A1C853	281-0767-00		CAP,FXD,CER DI:330PF,20%,100V	04222	MA106C331MAA
A1C854	283-0279-00		CAP,FXD,CER DI:0.001UF,20%,3000V	51406	DHR12Y5S102M3KV
A1C855	285-1184-00		CAP,FXD,MTLZD:0.01 UF,20%,4000V	56289	430P591
A1C871	283-0057-00		CAP,FXD,CER DI:0.1UF,+80-20%,200V	04222	SR306E104ZAA
A1C875	283-0057-00		CAP,FXD,CER DI:0.1UF,+80-20%,200V	04222	SR306E104ZAA
A1C893	283-0279-00		CAP,FXD,CER DI:0.001UF,20%,3000V	51406	DHR12Y5S102M3KV
A1C901	281-0815-00		CAP,FXD,CER DI:0.027UF,20%,50V	04222	MA205C273MAA
A1C902	281-0775-01		CAP,FXD,CER DI:0.1UF,20%,50V	04222	SA105E104MAA
A1C914	281-0814-00		CAP,FXD,CER DI:100 PF,10%,100V	04222	MA101A101KAA
A1C915	281-0775-01		CAP,FXD,CER DI:0.1UF,20%,50V	04222	SA105E104MAA
A1C920	281-0812-00		CAP,FXD,CER DI:1000PF,10%,100V	04222	MA101C102KAA
A1C925	281-0775-01		CAP,FXD,CER DI:0.1UF,20%,50V	04222	SA105E104MAA
A1C930	281-0812-00		CAP,FXD,CER DI:1000PF,10%,100V	04222	MA101C102KAA
A1C932	290-0806-00		CAP,FXD,ELCTLT:3.3UF,+75-10%,350VDC	55680	UHU2V3R3TPA
A1C933	281-0773-00		CAP,FXD,CER DI:0.01UF,10%,100V	04222	MA201C103KAA
A1C935	281-0775-01		CAP,FXD,CER DI:0.1UF,20%,50V	04222	SA105E104MAA
A1C941	281-0775-01		CAP,FXD,CER DI:0.1UF,20%,50V	04222	SA105E104MAA
A1C942	281-0773-00		CAP,FXD,CER DI:0.01UF,10%,100V	04222	MA201C103KAA
A1C943	281-0814-00		CAP,FXD,CER DI:100 PF,10%,100V	04222	MA101A101KAA
A1C945	281-0775-01		CAP,FXD,CER DI:0.1UF,20%,50V	04222	SA105E104MAA
A1C946	281-0814-00		CAP,FXD,CER DI:100 PF,10%,100V	04222	MA101A101KAA
A1C952	281-0775-01		CAP,FXD,CER DI:0.1UF,20%,50V	04222	SA105E104MAA
A1C974	281-0851-00		CAP,FXD,CER DI:180PF,5%,100VDC	04222	MA101A181JAA

Component No.	Tektronix	Serial/Assembly No.		Name & Description	Mfr.	Mfr. Part No.
	Part No.	Effective	Discont		Code	
A1C976	285-1184-00			CAP, FXD, MTLZD: 0.01 UF, 20%, 4000V	56289	430P591
A1C979	285-1184-00			CAP, FXD, MTLZD: 0.01 UF, 20%, 4000V	56289	430P591
A1C980	285-1184-00			CAP, FXD, MTLZD: 0.01 UF, 20%, 4000V	56289	430P591
A1C982	290-0947-00			CAP, FXD, ELCTLT: 33UF, +50-10%, 160V W/SLEEVE	55680	UHC2C330TFA
A1C983	290-0806-00			CAP, FXD, ELCTLT: 3.3UF, +75-10%, 350VDC	55680	UHU2V3R3TPA
A1C984	290-0947-00			CAP, FXD, ELCTLT: 33UF, +50-10%, 160V W/SLEEVE	55680	UHC2C330TFA
A1C985	290-0806-00			CAP, FXD, ELCTLT: 3.3UF, +75-10%, 350VDC	55680	UHU2V3R3TPA
A1C986	290-1159-00			CAP, FXD, ELCTLT: 1000UF, 20%, 16V	TKOED	TWSS
A1C987	290-1159-00			CAP, FXD, ELCTLT: 1000UF, 20%, 16V	TKOED	TWSS
A1C988	290-1159-00			CAP, FXD, ELCTLT: 1000UF, 20%, 16V	TKOED	TWSS
A1C989	290-1159-00			CAP, FXD, ELCTLT: 1000UF, 20%, 16V	TKOED	TWSS
A1C990	290-1159-00			CAP, FXD, ELCTLT: 1000UF, 20%, 16V	TKOED	TWSS
A1C991	290-1159-00			CAP, FXD, ELCTLT: 1000UF, 20%, 16V	TKOED	TWSS
A1C992	283-0057-00			CAP, FXD, CER, DI: 0.1UF, +80-20%, 200V	04222	SR306E104ZAA
A1CR133	152-0141-02			SEMICON DVC, DI: SW, SI, 30V, 150MA, 30V, DO-35	03508	DA2527 (1N4152)
A1CR136	152-0141-02			SEMICON DVC, DI: SW, SI, 30V, 150MA, 30V, DO-35	03508	DA2527 (1N4152)
A1CR139	152-0141-02			SEMICON DVC, DI: SW, SI, 30V, 150MA, 30V, DO-35	03508	DA2527 (1N4152)
A1CR183	152-0141-02			SEMICON DVC, DI: SW, SI, 30V, 150MA, 30V, DO-35	03508	DA2527 (1N4152)
A1CR186	152-0141-02			SEMICON DVC, DI: SW, SI, 30V, 150MA, 30V, DO-35	03508	DA2527 (1N4152)
A1CR189	152-0141-02			SEMICON DVC, DI: SW, SI, 30V, 150MA, 30V, DO-35	03508	DA2527 (1N4152)
A1CR265	152-0141-02			SEMICON DVC, DI: SW, SI, 30V, 150MA, 30V, DO-35	03508	DA2527 (1N4152)
A1CR266	152-0141-02			SEMICON DVC, DI: SW, SI, 30V, 150MA, 30V, DO-35	03508	DA2527 (1N4152)
A1CR300	152-0141-02			SEMICON DVC, DI: SW, SI, 30V, 150MA, 30V, DO-35	03508	DA2527 (1N4152)
A1CR301	152-0141-02			SEMICON DVC, DI: SW, SI, 30V, 150MA, 30V, DO-35	03508	DA2527 (1N4152)
A1CR302	152-0141-02			SEMICON DVC, DI: SW, SI, 30V, 150MA, 30V, DO-35	03508	DA2527 (1N4152)
A1CR319	152-0141-02			SEMICON DVC, DI: SW, SI, 30V, 150MA, 30V, DO-35	03508	DA2527 (1N4152)
A1CR344	152-0141-02			SEMICON DVC, DI: SW, SI, 30V, 150MA, 30V, DO-35	03508	DA2527 (1N4152)
A1CR348	152-0141-02			SEMICON DVC, DI: SW, SI, 30V, 150MA, 30V, DO-35	03508	DA2527 (1N4152)
A1CR349	152-0141-02			SEMICON DVC, DI: SW, SI, 30V, 150MA, 30V, DO-35	03508	DA2527 (1N4152)
A1CR381	152-0141-02			SEMICON DVC, DI: SW, SI, 30V, 150MA, 30V, DO-35	03508	DA2527 (1N4152)
A1CR417	152-0141-02			SEMICON DVC, DI: SW, SI, 30V, 150MA, 30V, DO-35	03508	DA2527 (1N4152)
A1CR431	152-0141-02			SEMICON DVC, DI: SW, SI, 30V, 150MA, 30V, DO-35	03508	DA2527 (1N4152)
A1CR450	152-0141-02			SEMICON DVC, DI: SW, SI, 30V, 150MA, 30V, DO-35	03508	DA2527 (1N4152)
A1CR451	152-0141-02			SEMICON DVC, DI: SW, SI, 30V, 150MA, 30V, DO-35	03508	DA2527 (1N4152)
A1CR452	152-0141-02			SEMICON DVC, DI: SW, SI, 30V, 150MA, 30V, DO-35	03508	DA2527 (1N4152)
A1CR521	152-0141-02			SEMICON DVC, DI: SW, SI, 30V, 150MA, 30V, DO-35	03508	DA2527 (1N4152)
A1CR530	152-0141-02			SEMICON DVC, DI: SW, SI, 30V, 150MA, 30V, DO-35	03508	DA2527 (1N4152)
A1CR539	152-0141-02			SEMICON DVC, DI: SW, SI, 30V, 150MA, 30V, DO-35	03508	DA2527 (1N4152)
A1CR540	152-0141-02			SEMICON DVC, DI: SW, SI, 30V, 150MA, 30V, DO-35	03508	DA2527 (1N4152)
A1CR571	152-0141-02			SEMICON DVC, DI: SW, SI, 30V, 150MA, 30V, DO-35	03508	DA2527 (1N4152)
A1CR584	152-0141-02			SEMICON DVC, DI: SW, SI, 30V, 150MA, 30V, DO-35	03508	DA2527 (1N4152)
A1CR588	152-0141-02			SEMICON DVC, DI: SW, SI, 30V, 150MA, 30V, DO-35	03508	DA2527 (1N4152)
A1CR589	152-0141-02			SEMICON DVC, DI: SW, SI, 30V, 150MA, 30V, DO-35	03508	DA2527 (1N4152)
A1CR780	152-0141-02			SEMICON DVC, DI: SW, SI, 30V, 150MA, 30V, DO-35	03508	DA2527 (1N4152)
A1CR781	152-0141-02			SEMICON DVC, DI: SW, SI, 30V, 150MA, 30V, DO-35	03508	DA2527 (1N4152)
A1CR790	152-0141-02			SEMICON DVC, DI: SW, SI, 30V, 150MA, 30V, DO-35	03508	DA2527 (1N4152)
A1CR791	152-0141-02			SEMICON DVC, DI: SW, SI, 30V, 150MA, 30V, DO-35	03508	DA2527 (1N4152)
A1CR817	152-0141-02			SEMICON DVC, DI: SW, SI, 30V, 150MA, 30V, DO-35	03508	DA2527 (1N4152)
A1CR818	152-0141-02			SEMICON DVC, DI: SW, SI, 30V, 150MA, 30V, DO-35	03508	DA2527 (1N4152)
A1CR819	152-0141-02			SEMICON DVC, DI: SW, SI, 30V, 150MA, 30V, DO-35	03508	DA2527 (1N4152)
A1CR820	152-0141-02			SEMICON DVC, DI: SW, SI, 30V, 150MA, 30V, DO-35	03508	DA2527 (1N4152)
A1CR824	152-0141-02			SEMICON DVC, DI: SW, SI, 30V, 150MA, 30V, DO-35	03508	DA2527 (1N4152)
A1CR825	152-0141-02			SEMICON DVC, DI: SW, SI, 30V, 150MA, 30V, DO-35	03508	DA2527 (1N4152)
A1CR827	152-0141-02			SEMICON DVC, DI: SW, SI, 30V, 150MA, 30V, DO-35	03508	DA2527 (1N4152)
A1CR828	152-0141-02			SEMICON DVC, DI: SW, SI, 30V, 150MA, 30V, DO-35	03508	DA2527 (1N4152)
A1CR829	152-0141-02			SEMICON DVC, DI: SW, SI, 30V, 150MA, 30V, DO-35	03508	DA2527 (1N4152)
A1CR840	152-0141-02			SEMICON DVC, DI: SW, SI, 30V, 150MA, 30V, DO-35	03508	DA2527 (1N4152)
A1CR845	152-0141-02			SEMICON DVC, DI: SW, SI, 30V, 150MA, 30V, DO-35	03508	DA2527 (1N4152)

Replaceable Electrical Parts - 2205 Service

Component No.	Tektronix Part No.	Serial/Assembly No. Effective Dscont	Name & Description	Mfr. Code	Mfr. Part No.
A1CR851	152-0400-00		SEMICON DVC,DI:RECT,SI,400V,1A	04713	SR1977KRL
A1CR853	152-0400-00		SEMICON DVC,DI:RECT,SI,400V,1A	04713	SR1977KRL
A1CR854	152-0400-00		SEMICON DVC,DI:RECT,SI,400V,1A	04713	SR1977KRL
A1CR855	152-0400-00		SEMICON DVC,DI:RECT,SI,400V,1A	04713	SR1977KRL
A1CR933	152-0141-02		SEMICON DVC,DI:SW,SI,30V,150MA,30V,DO-35	03508	DA2527 (1N4152)
A1CR941	152-0400-00		SEMICON DVC,DI:RECT,SI,400V,1A	04713	SR1977KRL
A1CR942	152-0400-00		SEMICON DVC,DI:RECT,SI,400V,1A	04713	SR1977KRL
A1CR945	152-0400-00		SEMICON DVC,DI:RECT,SI,400V,1A	04713	SR1977KRL
A1CR946	152-0400-00		SEMICON DVC,DI:RECT,SI,400V,1A	04713	SR1977KRL
A1CR947	152-0400-00		SEMICON DVC,DI:RECT,SI,400V,1A	04713	SR1977KRL
A1CR950	152-0906-00		SEMICON DVC,DI:RECT,SI,400V,3 AMP,50 NS	80009	152-0906-00
A1CR975	152-0429-00		SEMICON DVC,DI:RECT,SI,5KV,10MA,ED2137	83003	V65X-1
A1CR976	152-0429-00		SEMICON DVC,DI:RECT,SI,5KV,10MA,ED2137	83003	V65X-1
A1CR980	152-0400-00		SEMICON DVC,DI:RECT,SI,400V,1A	04713	SR1977KRL
A1CR981	152-0141-02		SEMICON DVC,DI:SW,SI,30V,150MA,30V,DO-35	03508	DA2527 (1N4152)
A1CR982	152-0400-00		SEMICON DVC,DI:RECT,SI,400V,1A	04713	SR1977KRL
A1CR983	152-0400-00		SEMICON DVC,DI:RECT,SI,400V,1A	04713	SR1977KRL
A1CR984	152-0400-00		SEMICON DVC,DI:RECT,SI,400V,1A	04713	SR1977KRL
A1CR985	152-0400-00		SEMICON DVC,DI:RECT,SI,400V,1A	04713	SR1977KRL
A1CR986	152-0400-00		SEMICON DVC,DI:RECT,SI,400V,1A	04713	SR1977KRL
A1CR987	152-0400-00		SEMICON DVC,DI:RECT,SI,400V,1A	04713	SR1977KRL
A1CR988	152-0400-00		SEMICON DVC,DI:RECT,SI,400V,1A	04713	SR1977KRL
A1CR989	152-0400-00		SEMICON DVC,DI:RECT,SI,400V,1A	04713	SR1977KRL
A1CR990	152-0400-00		SEMICON DVC,DI:RECT,SI,400V,1A	04713	SR1977KRL
A1CR991	152-0400-00		SEMICON DVC,DI:RECT,SI,400V,1A	04713	SR1977KRL
A1DS856	150-0035-00		LAMP,GLOW:90V MAX,0.3MA,AID-T,WIRE LD	TK0213	JH005/3011JA
A1DS858	150-0035-00		LAMP,GLOW:90V MAX,0.3MA,AID-T,WIRE LD	TK0213	JH005/3011JA
A1L321	108-1281-00		COIL,RF:FXD;2.2UH,10%	54583	SP0305-2R2K
A1L322	108-1281-00		COIL,RF:FXD;2.2UH,10%	54583	SP0305-2R2K
A1L950	108-1416-00		COIL,RF:POWER INDUCTOR,300UH-400UH,3A	80009	108-1416-00
A1L986	108-1375-00		COIL,RF:FXD,82UH,1A	TK00A	RL-1218-820K-1A
A1L988	108-1375-00		COIL,RF:FXD,82UH,1A	TK00A	RL-1218-820K-1A
A1L990	108-1375-00		COIL,RF:FXD,82UH,1A	TK00A	RL-1218-820K-1A
A1P910	136-0984-00		SKT,PL-IN ELEK:CRT,14 PIN,CABLE ASSY	80009	136-0984-00
A1Q102	151-0188-00		TRANSISTOR:PNP,SI,TO-92	80009	151-0188-00
A1Q103	151-0188-00		TRANSISTOR:PNP,SI,TO-92	80009	151-0188-00
A1Q104	151-0190-00		TRANSISTOR:NPN,SI,TO-92	80009	151-0190-00
A1Q105	151-0190-00		TRANSISTOR:NPN,SI,TO-92	80009	151-0190-00
A1Q114	151-0190-00		TRANSISTOR:NPN,SI,TO-92	80009	151-0190-00
A1Q115	151-0190-00		TRANSISTOR:NPN,SI,TO-92	80009	151-0190-00
A1Q152	151-0188-00		TRANSISTOR:PNP,SI,TO-92	80009	151-0188-00
A1Q153	151-0188-00		TRANSISTOR:PNP,SI,TO-92	80009	151-0188-00
A1Q154	151-0190-00		TRANSISTOR:NPN,SI,TO-92	80009	151-0190-00
A1Q155	151-0190-00		TRANSISTOR:NPN,SI,TO-92	80009	151-0190-00
A1Q164	151-0190-00		TRANSISTOR:NPN,SI,TO-92	80009	151-0190-00
A1Q165	151-0190-00		TRANSISTOR:NPN,SI,TO-92	80009	151-0190-00
A1Q202	151-0190-00		TRANSISTOR:NPN,SI,TO-92	80009	151-0190-00
A1Q203	151-0190-00		TRANSISTOR:NPN,SI,TO-92	80009	151-0190-00
A1Q206	151-0188-00		TRANSISTOR:PNP,SI,TO-92	80009	151-0188-00
A1Q207	151-0188-00		TRANSISTOR:PNP,SI,TO-92	80009	151-0188-00
A1Q230	151-0424-00		TRANSISTOR:NPN,SI,TO-92	04713	SPS8246
A1Q231	151-0424-00		TRANSISTOR:NPN,SI,TO-92	04713	SPS8246
A1Q232	151-0711-00		TRANSISTOR:NPN,SI,TO-92B	80009	151-0711-00
A1Q234	151-0711-00		TRANSISTOR:NPN,SI,TO-92B	80009	151-0711-00
A1Q236	151-0270-00		TRANSISTOR:PNP,SI,TO-39	04713	ST919
A1Q237	151-0124-00		TRANSISTOR:NPN,SI,TO-39	04713	SM8138
A1Q238	151-0270-00		TRANSISTOR:PNP,SI,TO-39	04713	ST919
A1Q239	151-0124-00		TRANSISTOR:NPN,SI,TO-39	04713	SM8138

Component No.	Tektronix Part No.	Serial/Assembly No. Effective Dscont	Name & Description	Mfr. Code	Mfr. Part No.
A1Q370	151-1042-00		SEMICOND DVC SE:FET,SI,TO-92	80009	151-1042-00
A1Q371	-----		(MATCHED PAIR WITH A1Q370)		
A1Q400	151-0712-00		TRANSISTOR:PNP,SI,TO-92	04713	SPS8223
A1Q401	151-0712-00		TRANSISTOR:PNP,SI,TO-92	04713	SPS8223
A1Q410	151-0190-00		TRANSISTOR:NPN,SI,TO-92	80009	151-0190-00
A1Q411	151-0190-00		TRANSISTOR:NPN,SI,TO-92	80009	151-0190-00
A1Q412	151-0190-00		TRANSISTOR:NPN,SI,TO-92	80009	151-0190-00
A1Q415	151-0188-00		TRANSISTOR:PNP,SI,TO-92	80009	151-0188-00
A1Q450	151-0190-00		TRANSISTOR:NPN,SI,TO-92	80009	151-0190-00
A1Q451	151-0190-00		TRANSISTOR:NPN,SI,TO-92	80009	151-0190-00
A1Q452	151-0190-00		TRANSISTOR:NPN,SI,TO-92	80009	151-0190-00
A1Q453	151-0190-00		TRANSISTOR:NPN,SI,TO-92	80009	151-0190-00
A1Q465	151-0188-00		TRANSISTOR:PNP,SI,TO-92	80009	151-0188-00
A1Q487	151-0188-00		TRANSISTOR:PNP,SI,TO-92	80009	151-0188-00
A1Q488	151-0188-00		TRANSISTOR:PNP,SI,TO-92	80009	151-0188-00
A1Q489	151-0188-00		TRANSISTOR:PNP,SI,TO-92	80009	151-0188-00
A1Q490	151-0188-00		TRANSISTOR:PNP,SI,TO-92	80009	151-0188-00
A1Q535	151-0188-00		TRANSISTOR:PNP,SI,TO-92	80009	151-0188-00
A1Q536	151-0188-00		TRANSISTOR:PNP,SI,TO-92	80009	151-0188-00
A1Q770	151-0188-00		TRANSISTOR:PNP,SI,TO-92	80009	151-0188-00
A1Q775	151-0573-00		TRANSISTOR:PWR,NPN,TO-126	80009	151-0573-00
A1Q776	151-0188-00		TRANSISTOR:PNP,SI,TO-92	80009	151-0188-00
A1Q779	151-0574-00		TRANSISTOR:PWR,PNP,TO-126	80009	151-0574-00
A1Q780	151-0190-00		TRANSISTOR:NPN,SI,TO-92	80009	151-0190-00
A1Q785	151-0573-00		TRANSISTOR:PWR,NPN,TO-126	80009	151-0573-00
A1Q789	151-0574-00		TRANSISTOR:PWR,PNP,TO-126	80009	151-0574-00
A1Q804	151-0188-00		TRANSISTOR:PNP,SI,TO-92	80009	151-0188-00
A1Q817	151-0190-00		TRANSISTOR:NPN,SI,TO-92	80009	151-0190-00
A1Q825	151-0190-00		TRANSISTOR:NPN,SI,TO-92	80009	151-0190-00
A1Q829	151-0188-00		TRANSISTOR:PNP,SI,TO-92	80009	151-0188-00
A1Q835	151-0199-00		TRANSISTOR:PNP,SI,TO-92	80009	151-0199-00
A1Q840	151-0347-02		TRANSISTOR:NPN,SI,TO-92	56289	CT7916
A1Q845	151-0350-00		TRANSISTOR:PNP,SI,TO-92	04713	SPS6700
A1Q932	151-0347-02		TRANSISTOR:NPN,SI,TO-92	56289	CT7916
A1Q933	151-1252-00		TRANSISTOR:PWR,MOS FET,P-CHANNEL,180V,1 OHM	80009	151-1252-00
A1Q935	151-0190-00		TRANSISTOR:NPN,SI,TO-92	80009	151-0190-00
A1Q939	151-0190-00		TRANSISTOR:NPN,SI,TO-92	80009	151-0190-00
A1Q941	151-0347-02		TRANSISTOR:NPN,SI,TO-92	56289	CT7916
A1Q942	151-0476-00		TRANSISTOR:NPN,SI,TO-220	80009	151-0476-00
A1Q943	151-0190-00		TRANSISTOR:NPN,SI,TO-92	80009	151-0190-00
A1Q945	151-0347-02		TRANSISTOR:NPN,SI,TO-92	56289	CT7916
A1Q946	151-0476-00		TRANSISTOR:NPN,SI,TO-220	80009	151-0476-00
A1Q982	151-0347-02		TRANSISTOR:NPN,SI,TO-92	56289	CT7916
A1Q985	151-0350-00		TRANSISTOR:PNP,SI,TO-92	04713	SPS6700
A1Q988	151-0347-02		TRANSISTOR:NPN,SI,TO-92	56289	CT7916
A1R100	315-0510-00		RES,FXD,FILM:51 OHM,5%,0.25W	19701	5043CX51R00J
A1R101	315-0510-00		RES,FXD,FILM:51 OHM,5%,0.25W	19701	5043CX51R00J
A1R102	315-0155-00		RES,FXD,FILM:1.5M OHM,5%,0.25W	19701	5043CX1M500J
A1R103	315-0155-00		RES,FXD,FILM:1.5M OHM,5%,0.25W	19701	5043CX1M500J
A1R104	321-0094-00		RES,FXD,FILM:93.1 OHM,1%,0.125W,TC=TO	91637	CMF55116693R10F
A1R105	321-0094-00		RES,FXD,FILM:93.1 OHM,1%,0.125W,TC=TO	91637	CMF55116693R10F
A1R106	321-0170-00		RES,FXD,FILM:576 OHM,1%,0.125W,TC=TO	07716	CEAD576R0F
A1R108	321-0223-00		RES,FXD,FILM:2.05K OHM,1%,0.125W,TC=TO	19701	5033ED2K05F
A1R109	321-0223-00		RES,FXD,FILM:2.05K OHM,1%,0.125W,TC=TO	19701	5033ED2K05F
A1R114	321-0223-00		RES,FXD,FILM:2.05K OHM,1%,0.125W,TC=TO	19701	5033ED2K05F
A1R115	321-0223-00		RES,FXD,FILM:2.05K OHM,1%,0.125W,TC=TO	19701	5033ED2K05F
A1R116	315-0101-00		RES,FXD,FILM:100 OHM,5%,0.25W	57668	NTR25J-E 100E
A1R117	315-0101-00		RES,FXD,FILM:100 OHM,5%,0.25W	57668	NTR25J-E 100E

Replaceable Electrical Parts - 2205 Service

Component No.	Tektronix Part No.	Serial/Assembly No. Effective Dscont	Name & Description	Mfr. Code	Mfr. Part No.
A1R118	315-0821-00		RES,FXD,FILM:820 OHM,5%,0.25W	19701	5043CX820R0J
A1R119	315-0821-00		RES,FXD,FILM:820 OHM,5%,0.25W	19701	5043CX820R0J
A1R120	321-0123-00		RES,FXD,FILM:187 OHM,1%,0.125W, TC=TO	07716	CEAD187R0F
A1R121	321-0123-00		RES,FXD,FILM:187 OHM,1%,0.125W, TC=TO	07716	CEAD187R0F
A1R122	321-0089-00		RES,FXD,FILM:82.5 OHM,1%,0.125W,TC=TO	91637	CMF55116682R50F
A1R124	315-0472-00		RES,FXD,FILM:4.7K OHM,5%,0.25W	57668	NTR25J-E04K7
A1R125	315-0392-00		RES,FXD,FILM:3.9K OHM,5%,0.25W	57668	NTR25J-E03K9
A1R126	315-0162-00		RES,FXD,FILM:1.6K OHM,5%,0.25W	19701	5043CX1K600J
A1R127	321-0068-00		RES,FXD,FILM:49.9 OHM,0.1%,0.125W,TC=TO	91637	CMF55116649R90F
A1R130	315-0510-00		RES,FXD,FILM:51 OHM,5%,0.25W	19701	5043CX51R00J
A1R131	315-0510-00		RES,FXD,FILM:51 OHM,5%,0.25W	19701	5043CX51R00J
A1R132	315-0511-00		RES,FXD,FILM:510 OHM,5%,0.25W	19701	5043CX510R0J
A1R133	315-0101-00		RES,FXD,FILM:100 OHM,5%,0.25W	57668	NTR25J-E 100E
A1R135	315-0101-00		RES,FXD,FILM:100 OHM,5%,0.25W	57668	NTR25J-E 100E
A1R136	315-0101-00		RES,FXD,FILM:100 OHM,5%,0.25W	57668	NTR25J-E 100E
A1R139	315-0102-00		RES,FXD,FILM:1K OHM,5%,0.25W	57668	NTR25JE01K0
A1R140	311-2364-00		RES,VAR,NONMW:TRMR,4.7K OHM,0.5W	K8788	TC10-LV10-4K7/A
A1R142	315-0101-00		RES,FXD,FILM:100 OHM,5%,0.25W	57668	NTR25J-E 100E
A1R143	315-0101-00		RES,FXD,FILM:100 OHM,5%,0.25W	57668	NTR25J-E 100E
A1R144	315-0471-00		RES,FXD,FILM:470 OHM,5%,0.25W	57668	NTR25J-E470E
A1R145	311-2364-00		RES,VAR,NONMW:TRMR,4.7K OHM,0.5W	K8788	TC10-LV10-4K7/A
A1R150	315-0510-00		RES,FXD,FILM:51 OHM,5%,0.25W	19701	5043CX51R00J
A1R151	315-0510-00		RES,FXD,FILM:51 OHM,5%,0.25W	19701	5043CX51R00J
A1R152	321-0155-00		RES,FXD,FILM:402 OHM,1%,0.125W,TC=TO	07716	CEAD402R0F
A1R153	321-0155-00		RES,FXD,FILM:402 OHM,1%,0.125W,TC=TO	07716	CEAD402R0F
A1R154	321-0094-00		RES,FXD,FILM:93.1 OHM,1%,0.125W,TC=TO	91637	CMF55116693R10F
A1R155	321-0094-00		RES,FXD,FILM:93.1 OHM,1%,0.125W,TC=TO	91637	CMF55116693R10F
A1R156	321-0170-00		RES,FXD,FILM:576 OHM,1%,0.125W,TC=TO	07716	CEAD576R0F
A1R158	321-0223-00		RES,FXD,FILM:2.05K OHM,1%,0.125W,TC=TO	19701	5033ED2K05F
A1R159	321-0223-00		RES,FXD,FILM:2.05K OHM,1%,0.125W,TC=TO	19701	5033ED2K05F
A1R161	307-0106-00		RES,FXD,CMPSPN:4.7 OHM,5%,0.25W	01121	CB 47G5
A1R162	307-0106-00		RES,FXD,CMPSPN:4.7 OHM,5%,0.25W	01121	CB 47G5
A1R164	321-0223-00		RES,FXD,FILM:2.05K OHM,1%,0.125W,TC=TO	19701	5033ED2K05F
A1R165	321-0223-00		RES,FXD,FILM:2.05K OHM,1%,0.125W,TC=TO	19701	5033ED2K05F
A1R166	315-0101-00		RES,FXD,FILM:100 OHM,5%,0.25W	57668	NTR25J-E 100E
A1R167	315-0101-00		RES,FXD,FILM:100 OHM,5%,0.25W	57668	NTR25J-E 100E
A1R168	315-0821-00		RES,FXD,FILM:820 OHM,5%,0.25W	19701	5043CX820R0J
A1R169	315-0821-00		RES,FXD,FILM:820 OHM,5%,0.25W	19701	5043CX820R0J
A1R170	321-0123-00		RES,FXD,FILM:187 OHM,1%,0.125W, TC=TO	07716	CEAD187R0F
A1R171	321-0123-00		RES,FXD,FILM:187 OHM,1%,0.125W, TC=TO	07716	CEAD187R0F
A1R172	321-0089-00		RES,FXD,FILM:82.5 OHM,1%,0.125W,TC=TO	91637	CMF55116682R50F
A1R174	315-0472-00		RES,FXD,FILM:4.7K OHM,5%,0.25W	57668	NTR25J-E04K7
A1R175	315-0392-00		RES,FXD,FILM:3.9K OHM,5%,0.25W	57668	NTR25J-E03K9
A1R176	315-0162-00		RES,FXD,FILM:1.6K OHM,5%,0.25W	19701	5043CX1K600J
A1R177	321-0068-00		RES,FXD,FILM:49.9 OHM,0.1%,0.125W,TC=TO	91637	CMF55116649R90F
A1R180	315-0510-00		RES,FXD,FILM:51 OHM,5%,0.25W	19701	5043CX51R00J
A1R181	315-0510-00		RES,FXD,FILM:51 OHM,5%,0.25W	19701	5043CX51R00J
A1R182	315-0511-00		RES,FXD,FILM:510 OHM,5%,0.25W	19701	5043CX510R0J
A1R183	315-0101-00		RES,FXD,FILM:100 OHM,5%,0.25W	57668	NTR25J-E 100E
A1R185	315-0101-00		RES,FXD,FILM:100 OHM,5%,0.25W	57668	NTR25J-E 100E
A1R186	315-0101-00		RES,FXD,FILM:100 OHM,5%,0.25W	57668	NTR25J-E 100E
A1R189	315-0392-00		RES,FXD,FILM:3.9K OHM,5%,0.25W	57668	NTR25J-E03K9
A1R192	315-0101-00		RES,FXD,FILM:100 OHM,5%,0.25W	57668	NTR25J-E 100E
A1R193	315-0101-00		RES,FXD,FILM:100 OHM,5%,0.25W	57668	NTR25J-E 100E
A1R194	315-0471-00		RES,FXD,FILM:470 OHM,5%,0.25W	57668	NTR25J-E470E
A1R195	311-2364-00		RES,VAR,NONMW:TRMR,4.7K OHM,0.5W	K8788	TC10-LV10-4K7/A
A1R202	321-0178-00		RES,FXD,FILM:698 OHM,1%,0.125W,TC=TO	07716	CEAD698R0F
A1R203	321-0178-00		RES,FXD,FILM:698 OHM,1%,0.125W,TC=TO	07716	CEAD698R0F

Component No.	Tektronix Part No.	Serial/Assembly No. Effective Dscnt	Name & Description	Mfr. Code	Mfr. Part No.
A1R204	321-0089-00		RES, FXD, FILM: 82.5 OHM, 1%, 0.125W, TC=TO	91637	CMF55116682R50F
A1R206	315-0271-00		RES, FXD, FILM: 270 OHM, 5%, 0.25W	57668	NTR25J-E270E
A1R207	315-0271-00		RES, FXD, FILM: 270 OHM, 5%, 0.25W	57668	NTR25J-E270E
A1R212	321-0094-00		RES, FXD, FILM: 93.1 OHM, 1%, 0.125W, TC=TO	91637	CMF55116693R10F
A1R213	321-0094-00		RES, FXD, FILM: 93.1 OHM, 1%, 0.125W, TC=TO	91637	CMF55116693R10F
A1R215	315-0241-00		RES, FXD, FILM: 240 OHM, 5%, 0.25W	19701	5043CX240R0J
A1R216	321-0163-00		RES, FXD, FILM: 487 OHM, 1%, 0.125W, TC=TO	07716	CEAD487R0F
A1R217	321-0163-00		RES, FXD, FILM: 487 OHM, 1%, 0.125W, TC=TO	07716	CEAD487R0F
A1R218	321-0109-00		RES, FXD, FILM: 133 OHM, 1%, 0.125W, TC=TO	07716	CEAD133R0F
A1R219	321-0109-00		RES, FXD, FILM: 133 OHM, 1%, 0.125W, TC=TO	07716	CEAD133R0F
A1R220	315-0100-00		RES, FXD, FILM: 10 OHM, 5%, 0.25W	19701	5043CX10R00J
A1R221	315-0100-00		RES, FXD, FILM: 10 OHM, 5%, 0.25W	19701	5043CX10R00J
A1R222	321-0318-00		RES, FXD, FILM: 20.0K OHM, 1%, 0.125W, TC=TO	19701	5033ED20K00F
A1R223	321-0318-00		RES, FXD, FILM: 20.0K OHM, 1%, 0.125W, TC=TO	19701	5033ED20K00F
A1R225	315-0752-00		RES, FXD, FILM: 7.5K OHM, 5%, 0.25W	57668	NTR25J-E07K5
A1R226	315-0512-00		RES, FXD, FILM: 5.1K OHM, 5%, 0.25W	57668	NTR25J-E05K1
A1R232	321-0238-00		RES, FXD, FILM: 2.94K OHM, 1%, 0.125W, TC=TO	07716	CEAD29400F
A1R233	321-0139-00		RES, FXD, FILM: 274 OHM, 1%, 0.125W, TC=TO	07716	CEAD274R0F
A1R235	321-0238-00		RES, FXD, FILM: 2.94K OHM, 1%, 0.125W, TC=TO	07716	CEAD29400F
A1R237	315-0120-00		RES, FXD, FILM: 12 OHM, 5%, 0.25W	57668	NTR25J-R12
A1R238	315-0913-00		RES, FXD, FILM: 91K OHM, 5%, 0.25W	19701	5043CX91K00J
A1R239	315-0331-00		RES, FXD, FILM: 330 OHM, 5%, 0.25W	57668	NTR25J-E330E
A1R241	311-2363-00		RES, VAR, NONW: TRMR, 1K OHM, 0.5W	K8788	TC10-LV10-1K/A
A1R242	323-0310-00		RES, FXD, FILM: 16.5K OHM, 1%, 0.5W, TC=TO	75042	CECT0-1652F
A1R243	323-0310-00		RES, FXD, FILM: 16.5K OHM, 1%, 0.5W, TC=TO	75042	CECT0-1652F
A1R244	307-0106-00		RES, FXD, CMPSN: 4.7 OHM, 5%, 0.25W	01121	CB 47G5
A1R245	315-0222-00		RES, FXD, FILM: 2.2K OHM, 5%, 0.25W	57668	NTR25J-E02K2
A1R246	315-0620-00		RES, FXD, FILM: 62 OHM, 5%, 0.25W	19701	5043CX63R00J
A1R247	315-0120-00		RES, FXD, FILM: 12 OHM, 5%, 0.25W	57668	NTR25J-R12
A1R248	315-0331-00		RES, FXD, FILM: 330 OHM, 5%, 0.25W	57668	NTR25J-E330E
A1R249	315-0913-00		RES, FXD, FILM: 91K OHM, 5%, 0.25W	19701	5043CX91K00J
A1R250	315-0222-00		RES, FXD, FILM: 2.2K OHM, 5%, 0.25W	57668	NTR25J-E02K2
A1R251	307-0106-00		RES, FXD, CMPSN: 4.7 OHM, 5%, 0.25W	01121	CB 47G5
A1R252	315-0620-00		RES, FXD, FILM: 62 OHM, 5%, 0.25W	19701	5043CX63R00J
A1R253	315-0272-00		RES, FXD, FILM: 2.7K OHM, 5%, 0.25W	57668	NTR25J-E02K7
A1R258	315-0272-00		RES, FXD, FILM: 2.7K OHM, 5%, 0.25W	57668	NTR25J-E02K7
A1R260	315-0240-00		RES, FXD, FILM: 24 OHM, 5%, 0.25W	57668	NTR25J-E24E0
A1R262	315-0103-00		RES, FXD, FILM: 10K OHM, 5%, 0.25W	19701	5043CX10K00J
A1R263	301-0431-00		RES, FXD, FILM: 430 OHM, 5%, 0.5W	19701	5053CX430R0J
A1R264	301-0431-00		RES, FXD, FILM: 430 OHM, 5%, 0.5W	19701	5053CX430R0J
A1R265	315-0510-00		RES, FXD, FILM: 51 OHM, 5%, 0.25W	19701	5043CX51R00J
A1R266	315-0510-00		RES, FXD, FILM: 51 OHM, 5%, 0.25W	19701	5043CX51R00J
A1R267	308-0286-00		RES, FXD, WW: 8.2K OHM, 5%, 3W	00213	1240S-8200-5
A1R268	308-0286-00		RES, FXD, WW: 8.2K OHM, 5%, 3W	00213	1240S-8200-5
A1R269	315-0510-00		RES, FXD, FILM: 51 OHM, 5%, 0.25W	19701	5043CX51R00J
A1R280	321-0148-00		RES, FXD, FILM: 340 OHM, 1%, 0.125W, TC=TO	07716	CEAD340R0F
A1R300	315-0273-00		RES, FXD, FILM: 27K OHM, 5%, 0.25W	57668	NTR25J-E27K0
A1R301	315-0273-00		RES, FXD, FILM: 27K OHM, 5%, 0.25W	57668	NTR25J-E27K0
A1R302	315-0103-00		RES, FXD, FILM: 10K OHM, 5%, 0.25W	19701	5043CX10K00J
A1R303	315-0203-00		RES, FXD, FILM: 20K OHM, 5%, 0.25W	57668	NTR25J-E 20K
A1R304	315-0103-00		RES, FXD, FILM: 10K OHM, 5%, 0.25W	19701	5043CX10K00J
A1R305	315-0103-00		RES, FXD, FILM: 10K OHM, 5%, 0.25W	19701	5043CX10K00J
A1R306	315-0103-00		RES, FXD, FILM: 10K OHM, 5%, 0.25W	19701	5043CX10K00J
A1R308	315-0203-00		RES, FXD, FILM: 20K OHM, 5%, 0.25W	57668	NTR25J-E 20K
A1R309	315-0103-00		RES, FXD, FILM: 10K OHM, 5%, 0.25W	19701	5043CX10K00J
A1R310	307-0106-00		RES, FXD, CMPSN: 4.7 OHM, 5%, 0.25W	01121	CB 47G5
A1R311	307-0106-00		RES, FXD, CMPSN: 4.7 OHM, 5%, 0.25W	01121	CB 47G5
A1R312	307-0106-00		RES, FXD, CMPSN: 4.7 OHM, 5%, 0.25W	01121	CB 47G5

Replaceable Electrical Parts - 2205 Service

Component No.	Tektronix Part No.	Serial/Assembly No. Effective Dscnt	Name & Description	Mfr. Code	Mfr. Part No.
A1R316	321-0098-00		RES, FXD, FILM:102 OHM, 1%, 0.125W, TC=TO	07716	CEAD102R0F
A1R317	315-0241-00		RES, FXD, FILM:240 OHM, 5%, 0.25W	19701	5043CX240R0J
A1R318	315-0241-00		RES, FXD, FILM:240 OHM, 5%, 0.25W	19701	5043CX240R0J
A1R319	315-0102-00		RES, FXD, FILM:1K OHM, 5%, 0.25W	57668	NTR25JE01K0
A1R320	315-0102-00		RES, FXD, FILM:1K OHM, 5%, 0.25W	57668	NTR25JE01K0
A1R322	321-0203-00		RES, FXD, FILM:1.27K OHM, 1%, 0.125W, TC=TO	07716	CEAD12700F
A1R323	321-0203-00		RES, FXD, FILM:1.27K OHM, 1%, 0.125W, TC=TO	07716	CEAD12700F
A1R325	321-0170-00		RES, FXD, FILM:576 OHM, 1%, 0.125W, TC=TO	07716	CEAD576R0F
A1R326	321-0170-00		RES, FXD, FILM:576 OHM, 1%, 0.125W, TC=TO	07716	CEAD576R0F
A1R329	321-0314-00		RES, FXD, FILM:18.2K OHM, 1%, 0.125W, TC=TO	19701	5043ED18K20F
A1R330	321-0317-00		RES, FXD, FILM:19.6K OHM, 1%, 0.125W, TC=TO	07716	CEAD19601F
A1R331	315-0241-00		RES, FXD, FILM:240 OHM, 5%, 0.25W	19701	5043CX240R0J
A1R332	315-0241-00		RES, FXD, FILM:240 OHM, 5%, 0.25W	19701	5043CX240R0J
A1R333	315-0102-00		RES, FXD, FILM:1K OHM, 5%, 0.25W	57668	NTR25JE01K0
A1R334	315-0102-00		RES, FXD, FILM:1K OHM, 5%, 0.25W	57668	NTR25JE01K0
A1R335	321-0098-00		RES, FXD, FILM:102 OHM, 1%, 0.125W, TC=TO	07716	CEAD102R0F
A1R336	321-0194-00		RES, FXD, FILM:1.02K OHM, 1%, 0.125W, TC=TO	07716	CEAD10200F
A1R337	321-0194-00		RES, FXD, FILM:1.02K OHM, 1%, 0.125W, TC=TO	07716	CEAD10200F
A1R338	311-2365-00		RES, VAR, NONMW:TRMR, 470 OHM, 0.75W	K8788	TC10-LV10-470K/A
A1R339	321-0170-00		RES, FXD, FILM:576 OHM, 1%, 0.125W, TC=TO	07716	CEAD576R0F
A1R340	321-0170-00		RES, FXD, FILM:576 OHM, 1%, 0.125W, TC=TO	07716	CEAD576R0F
A1R343	321-0314-00		RES, FXD, FILM:18.2K OHM, 1%, 0.125W, TC=TO	19701	5043ED18K20F
A1R344	321-0317-00		RES, FXD, FILM:19.6K OHM, 1%, 0.125W, TC=TO	07716	CEAD19601F
A1R350	315-0470-00		RES, FXD, FILM:47 OHM, 5%, 0.25W	57668	NTR25J-E47E0
A1R351	315-0470-00		RES, FXD, FILM:47 OHM, 5%, 0.25W	57668	NTR25J-E47E0
A1R352	321-0274-00		RES, FXD, FILM:6.98K OHM, 1%, 0.125W, TC=TO	19701	5043ED6K980F
A1R353	321-0274-00		RES, FXD, FILM:6.98K OHM, 1%, 0.125W, TC=TO	19701	5043ED6K980F
A1R354	315-0272-00		RES, FXD, FILM:2.7K OHM, 5%, 0.25W	57668	NTR25J-E02K7
A1R356	315-0622-00		RES, FXD, FILM:6.2K OHM, 5%, 0.25W	19701	5043CX6K200J
A1R357	321-0149-00		RES, FXD, FILM:348 OHM, 1%, 0.125W, TC=TO	07716	CEAD348R0F
A1R358	315-0101-00		RES, FXD, FILM:100 OHM, 5%, 0.25W	57668	NTR25J-E 100E
A1R359	321-0148-00		RES, FXD, FILM:340 OHM, 1%, 0.125W, TC=TO	07716	CEAD340R0F
A1R360	321-0156-00		RES, FXD, FILM:412 OHM, 1%, 0.125W, TC=TO	07716	CEAD412R0F
A1R361	315-0202-00		RES, FXD, FILM:2K OHM, 5%, 0.25W	57668	NTR25J-E 2K
A1R362	315-0112-00		RES, FXD, FILM:1.1K OHM, 5%, 0.25W	19701	5043CX1K100J
A1R363	315-0392-00		RES, FXD, FILM:3.9K OHM, 5%, 0.25W	57668	NTR25J-E03K9
A1R364	315-0104-00		RES, FXD, FILM:100K OHM, 5%, 0.25W	57668	NTR25J-E100K
A1R366	315-0242-00		RES, FXD, FILM:2.4K OHM, 5%, 0.25W	57668	NTR25J-E02K4
A1R367	315-0392-00		RES, FXD, FILM:3.9K OHM, 5%, 0.25W	57668	NTR25J-E03K9
A1R368	315-0152-00		RES, FXD, FILM:1.5K OHM, 5%, 0.25W	57668	NTR25J-E01K5
A1R369	315-0432-00		RES, FXD, FILM:4.3K OHM, 5%, 0.25W	57668	NTR25J-E04K3
A1R370	315-0470-00		RES, FXD, FILM:47 OHM, 5%, 0.25W	57668	NTR25J-E47E0
A1R371	315-0121-00		RES, FXD, FILM:120 OHM, 5%, 0.25W	19701	5043CX120R0J
A1R372	315-0101-00		RES, FXD, FILM:100 OHM, 5%, 0.25W	57668	NTR25J-E 100E
A1R373	315-0120-00		RES, FXD, FILM:12 OHM, 5%, 0.25W	57668	NTR25J-R12
A1R374	315-0101-00		RES, FXD, FILM:100 OHM, 5%, 0.25W	57668	NTR25J-E 100E
A1R380	315-0202-00		RES, FXD, FILM:2K OHM, 5%, 0.25W	57668	NTR25J-E 2K
A1R381	315-0101-00		RES, FXD, FILM:100 OHM, 5%, 0.25W	57668	NTR25J-E 100E
A1R389	315-0100-00		RES, FXD, FILM:10 OHM, 5%, 0.25W	19701	5043CX10RR00J
A1R394	315-0103-00		RES, FXD, FILM:10K OHM, 5%, 0.25W	19701	5043CX10K00J
A1R395	311-2365-00		RES, VAR, NONMW:TRMR, 470 OHM, 0.75W	K8788	TC10-LV10-470K/A
A1R396	315-0751-00		RES, FXD, FILM:750 OHM, 5%, 0.25W	57668	NTR25J-E750E
A1R400	321-0089-00		RES, FXD, FILM:82.5 OHM, 1%, 0.125W, TC=TO	91637	CMF55116682R50F
A1R401	321-0089-00		RES, FXD, FILM:82.5 OHM, 1%, 0.125W, TC=TO	91637	CMF55116682R50F
A1R402	315-0102-00		RES, FXD, FILM:1K OHM, 5%, 0.25W	57668	NTR25JE01K0
A1R403	315-0470-00		RES, FXD, FILM:47 OHM, 5%, 0.25W	57668	NTR25J-E47E0
A1R404	315-0204-00		RES, FXD, FILM:200K OHM, 5%, 0.25W	19701	5043CX200K0J
A1R405	315-0103-00		RES, FXD, FILM:10K OHM, 5%, 0.25W	19701	5043CX10K00J

Component No.	Tektronix Part No.	Serial/Assembly No. Effective Discnt	Name & Description	Mfr. Code	Mfr. Part No.
A1R406	315-0202-00		RES, FXD, FILM: 2K OHM, 5%, 0.25W	57668	NTR25J-E 2K
A1R407	315-0102-00		RES, FXD, FILM: 1K OHM, 5%, 0.25W	57668	NTR25JE01K0
A1R408	315-0202-00		RES, FXD, FILM: 2K OHM, 5%, 0.25W	57668	NTR25J-E 2K
A1R409	315-0302-00		RES, FXD, FILM: 3K OHM, 5%, 0.25W	57668	NTR25J-E03K0
A1R410	315-0392-00		RES, FXD, FILM: 3.9K OHM, 5%, 0.25W	57668	NTR25J-E03K9
A1R411	315-0432-00		RES, FXD, FILM: 4.3K OHM, 5%, 0.25W	57668	NTR25J-E04K3
A1R412	315-0103-00		RES, FXD, FILM: 10K OHM, 5%, 0.25W	19701	5043CX10K00J
A1R413	315-0751-00		RES, FXD, FILM: 750 OHM, 5%, 0.25W	57668	NTR25J-E750E
A1R414	315-0752-00		RES, FXD, FILM: 7.5K OHM, 5%, 0.25W	57668	NTR25J-E07K5
A1R415	315-0120-00		RES, FXD, FILM: 12 OHM, 5%, 0.25W	57668	NTR25J-R12
A1R416	315-0823-00		RES, FXD, FILM: 82K OHM, 5%, 0.25W	57668	NTR25J-E82K
A1R417	315-0562-00		RES, FXD, FILM: 5.6K OHM, 5%, 0.25W	57668	NTR25J-E05K6
A1R418	315-0204-00		RES, FXD, FILM: 200K OHM, 5%, 0.25W	19701	5043CX200K0J
A1R419	315-0470-00		RES, FXD, FILM: 47 OHM, 5%, 0.25W	57668	NTR25J-E47E0
A1R426	315-0751-00		RES, FXD, FILM: 750 OHM, 5%, 0.25W	57668	NTR25J-E750E
A1R427	315-0362-00		RES, FXD, FILM: 3.6K OHM, 5%, 0.25W	19701	5043CX3K600J
A1R428	315-0752-00		RES, FXD, FILM: 7.5K OHM, 5%, 0.25W	57668	NTR25J-E07K5
A1R429	315-0204-00		RES, FXD, FILM: 200K OHM, 5%, 0.25W	19701	5043CX200K0J
A1R430	315-0823-00		RES, FXD, FILM: 82K OHM, 5%, 0.25W	57668	NTR25J-E82K
A1R431	307-0106-00		RES, FXD, CMPSN: 4.7 OHM, 5%, 0.25W	01121	CB 47G5
A1R432	315-0204-00		RES, FXD, FILM: 200K OHM, 5%, 0.25W	19701	5043CX200K0J
A1R433	315-0223-00		RES, FXD, FILM: 22K OHM, 5%, 0.25W	19701	5043CX22K00J92U
A1R435	315-0120-00		RES, FXD, FILM: 12 OHM, 5%, 0.25W	57668	NTR25J-R12
A1R441	321-0238-00		RES, FXD, FILM: 2.94K OHM, 1%, 0.125W, TC=TO	07716	CEAD29400F
A1R442	321-0208-00		RES, FXD, FILM: 1.43K OHM, 1%, 0.125W, TC=TO	19701	5033ED1K43F
A1R443	321-0238-00		RES, FXD, FILM: 2.94K OHM, 1%, 0.125W, TC=TO	07716	CEAD29400F
A1R444	321-0208-00		RES, FXD, FILM: 1.43K OHM, 1%, 0.125W, TC=TO	19701	5033ED1K43F
A1R445	311-1550-00		RES, VAR, NONNW: TRMR, 2M OHM, 0.5W	32997	3352T-1-205
A1R446	311-1550-00		RES, VAR, NONNW: TRMR, 2M OHM, 0.5W	32997	3352T-1-205
A1R450	315-0202-00		RES, FXD, FILM: 2K OHM, 5%, 0.25W	57668	NTR25J-E 2K
A1R451	315-0101-00		RES, FXD, FILM: 100 OHM, 5%, 0.25W	57668	NTR25J-E 100E
A1R480	315-0103-00		RES, FXD, FILM: 10K OHM, 5%, 0.25W	19701	5043CX10K00J
A1R481	311-2361-00		RES, VAR, NONNW: TRMR, 10K OHM, 0.5W	K8788	TC10-LV10-10K/A
A1R482	315-0271-00		RES, FXD, FILM: 270 OHM, 5%, 0.25W	57668	NTR25J-E270E
A1R483	315-0431-00		RES, FXD, FILM: 430 OHM, 5%, 0.25W	19701	5043CX430R0J
A1R485	321-0089-00		RES, FXD, FILM: 82.5 OHM, 1%, 0.125W, TC=TO	91637	CMF55116682R50F
A1R486	315-0222-00		RES, FXD, FILM: 2.2K OHM, 5%, 0.25W	57668	NTR25J-E02K2
A1R487	315-0103-00		RES, FXD, FILM: 10K OHM, 5%, 0.25W	19701	5043CX10K00J
A1R488	315-0391-00		RES, FXD, FILM: 390 OHM, 5%, 0.25W	57668	NTR25J-E390E
A1R489	311-2352-00		RES, VAR, NONNW: TRMR, 220 OHM, 0.5W	K8788	TC10LV2.5220R
A1R490	315-0392-00		RES, FXD, FILM: 3.9K OHM, 5%, 0.25W	57668	NTR25J-E03K9
A1R491	315-0391-00		RES, FXD, FILM: 390 OHM, 5%, 0.25W	57668	NTR25J-E390E
A1R492	315-0102-00		RES, FXD, FILM: 1K OHM, 5%, 0.25W	57668	NTR25JE01K0
A1R493	315-0103-00		RES, FXD, FILM: 10K OHM, 5%, 0.25W	19701	5043CX10K00J
A1R495	315-0752-00		RES, FXD, FILM: 7.5K OHM, 5%, 0.25W	57668	NTR25J-E07K5
A1R496	315-0752-00		RES, FXD, FILM: 7.5K OHM, 5%, 0.25W	57668	NTR25J-E07K5
A1R497	315-0471-00		RES, FXD, FILM: 470 OHM, 5%, 0.25W	57668	NTR25J-E470E
A1R498	315-0431-00		RES, FXD, FILM: 430 OHM, 5%, 0.25W	19701	5043CX430R0J
A1R501	321-0322-00		RES, FXD, FILM: 22.1K OHM, 0.1%, 0.125W, TC=TO	19701	5033ED22K10F
A1R502	321-0318-00		RES, FXD, FILM: 20.0K OHM, 1%, 0.125W, TC=TO	19701	5033ED20K00F
A1R503	321-0318-00		RES, FXD, FILM: 20.0K OHM, 1%, 0.125W, TC=TO	19701	5033ED20K00F
A1R504	315-0202-00		RES, FXD, FILM: 2K OHM, 5%, 0.25W	57668	NTR25J-E 2K
A1R505	315-0334-00		RES, FXD, FILM: 330K OHM, 5%, 0.25W	57668	NTR25J-E 330K
A1R506	315-0202-00		RES, FXD, FILM: 2K OHM, 5%, 0.25W	57668	NTR25J-E 2K
A1R508	315-0102-00		RES, FXD, FILM: 1K OHM, 5%, 0.25W	57668	NTR25JE01K0
A1R512	315-0102-00		RES, FXD, FILM: 1K OHM, 5%, 0.25W	57668	NTR25JE01K0
A1R515	315-0101-00		RES, FXD, FILM: 100 OHM, 5%, 0.25W	57668	NTR25J-E 100E
A1R517	315-0682-00		RES, FXD, FILM: 6.8K OHM, 5%, 0.25W	57668	NTR25J-E06K8

Replaceable Electrical Parts - 2205 Service

Component No.	Tektronix Part No.	Serial/Assembly No. Effective Dscont	Name & Description	Mfr. Code	Mfr. Part No.
A1R518	315-0912-00		RES,FXD,FILM:9.1K OHM,5%,0.25W	57668	NTR25J-E09K1
A1R520	315-0102-00		RES,FXD,FILM:1K OHM,5%,0.25W	57668	NTR25JE01K0
A1R521	315-0182-00		RES,FXD,FILM:1.8K OHM,5%,0.25W	57668	NTR25J-E1K8
A1R522	315-0102-00		RES,FXD,FILM:1K OHM,5%,0.25W	57668	NTR25JE01K0
A1R523	315-0102-00		RES,FXD,FILM:1K OHM,5%,0.25W	57668	NTR25JE01K0
A1R524	315-0102-00		RES,FXD,FILM:1K OHM,5%,0.25W	57668	NTR25JE01K0
A1R525	315-0222-00		RES,FXD,FILM:2.2K OHM,5%,0.25W	57668	NTR25J-E02K2
A1R526	315-0222-00		RES,FXD,FILM:2.2K OHM,5%,0.25W	57668	NTR25J-E02K2
A1R530	315-0101-00		RES,FXD,FILM:100 OHM,5%,0.25W	57668	NTR25J-E 100E
A1R531	315-0102-00		RES,FXD,FILM:1K OHM,5%,0.25W	57668	NTR25JE01K0
A1R532	315-0222-00		RES,FXD,FILM:2.2K OHM,5%,0.25W	57668	NTR25J-E02K2
A1R533	315-0511-00		RES,FXD,FILM:510 OHM,5%,0.25W	19701	5043CX510R0J
A1R534	315-0511-00		RES,FXD,FILM:510 OHM,5%,0.25W	19701	5043CX510R0J
A1R535	315-0181-00		RES,FXD,FILM:180 OHM,5%,0.25W	57668	NTR25J-E180E
A1R536	315-0181-00		RES,FXD,FILM:180 OHM,5%,0.25W	57668	NTR25J-E180E
A1R537	315-0221-00		RES,FXD,FILM:220 OHM,5%,0.25W	57668	NTR25J-E220E
A1R538	315-0512-00		RES,FXD,FILM:5.1K OHM,5%,0.25W	57668	NTR25J-E05K1
A1R539	315-0512-00		RES,FXD,FILM:5.1K OHM,5%,0.25W	57668	NTR25J-E05K1
A1R540	315-0511-00		RES,FXD,FILM:510 OHM,5%,0.25W	19701	5043CX510R0J
A1R541	315-0511-00		RES,FXD,FILM:510 OHM,5%,0.25W	19701	5043CX510R0J
A1R542	315-0103-00		RES,FXD,FILM:10K OHM,5%,0.25W	19701	5043CX10K00J
A1R543	315-0103-00		RES,FXD,FILM:10K OHM,5%,0.25W	19701	5043CX10K00J
A1R544	315-0431-00		RES,FXD,FILM:430 OHM,5%,0.25W	19701	5043CX430R0J
A1R545	315-0102-00		RES,FXD,FILM:1K OHM,5%,0.25W	57668	NTR25JE01K0
A1R547	315-0102-00		RES,FXD,FILM:1K OHM,5%,0.25W	57668	NTR25JE01K0
A1R548	315-0102-00		RES,FXD,FILM:1K OHM,5%,0.25W	57668	NTR25JE01K0
A1R549	315-0621-00		RES,FXD,FILM:620 OHM,5%,0.25W	57668	NTR25J-E620E
A1R550	315-0512-00		RES,FXD,FILM:5.1K OHM,5%,0.25W	57668	NTR25J-E05K1
A1R551	315-0182-00		RES,FXD,FILM:1.8K OHM,5%,0.25W	57668	NTR25J-E1K8
A1R552	315-0222-00		RES,FXD,FILM:2.2K OHM,5%,0.25W	57668	NTR25J-E02K2
A1R553	315-0511-00		RES,FXD,FILM:510 OHM,5%,0.25W	19701	5043CX510R0J
A1R554	315-0222-00		RES,FXD,FILM:2.2K OHM,5%,0.25W	57668	NTR25J-E02K2
A1R555	315-0391-00		RES,FXD,FILM:390 OHM,5%,0.25W	57668	NTR25J-E390E
A1R556	315-0222-00		RES,FXD,FILM:2.2K OHM,5%,0.25W	57668	NTR25J-E02K2
A1R557	315-0102-00		RES,FXD,FILM:1K OHM,5%,0.25W	57668	NTR25JE01K0
A1R560	315-0271-00		RES,FXD,FILM:270 OHM,5%,0.25W	57668	NTR25J-E270E
A1R561	315-0512-00		RES,FXD,FILM:5.1K OHM,5%,0.25W	57668	NTR25J-E05K1
A1R562	315-0392-00		RES,FXD,FILM:3.9K OHM,5%,0.25W	57668	NTR25J-E03K9
A1R563	315-0222-00		RES,FXD,FILM:2.2K OHM,5%,0.25W	57668	NTR25J-E02K2
A1R564	315-0511-00		RES,FXD,FILM:510 OHM,5%,0.25W	19701	5043CX510R0J
A1R565	315-0103-00		RES,FXD,FILM:10K OHM,5%,0.25W	19701	5043CX10K00J
A1R566	315-0752-00		RES,FXD,FILM:7.5K OHM,5%,0.25W	57668	NTR25J-E07K5
A1R567	315-0103-00		RES,FXD,FILM:10K OHM,5%,0.25W	19701	5043CX10K00J
A1R570	315-0392-00		RES,FXD,FILM:3.9K OHM,5%,0.25W	57668	NTR25J-E03K9
A1R571	315-0392-00		RES,FXD,FILM:3.9K OHM,5%,0.25W	57668	NTR25J-E03K9
A1R572	315-0222-00		RES,FXD,FILM:2.2K OHM,5%,0.25W	57668	NTR25J-E02K2
A1R573	315-0222-00		RES,FXD,FILM:2.2K OHM,5%,0.25W	57668	NTR25J-E02K2
A1R574	315-0222-00		RES,FXD,FILM:2.2K OHM,5%,0.25W	57668	NTR25J-E02K2
A1R576	315-0222-00		RES,FXD,FILM:2.2K OHM,5%,0.25W	57668	NTR25J-E02K2
A1R579	315-0221-00		RES,FXD,FILM:220 OHM,5%,0.25W	57668	NTR25J-E220E
A1R581	315-0103-00		RES,FXD,FILM:10K OHM,5%,0.25W	19701	5043CX10K00J
A1R582	321-0361-00		RES,FXD,FILM:56.2K OHM,1%,0.125W,TC=TO	07716	CEAD56201F
A1R583	315-0204-00		RES,FXD,FILM:200K OHM,5%,0.25W	19701	5043CX200K0J
A1R584	315-0474-00		RES,FXD,FILM:470K OHM,5%,0.25W	19701	5043CX470K0J92U
A1R585	315-0104-00		RES,FXD,FILM:100K OHM,5%,0.25W	57668	NTR25J-E100K
A1R586	315-0334-00		RES,FXD,FILM:330K OHM,5%,0.25W	57668	NTR25J-E 330K
A1R587	315-0104-00		RES,FXD,FILM:100K OHM,5%,0.25W	57668	NTR25J-E100K
A1R588	315-0182-00		RES,FXD,FILM:1.8K OHM,5%,0.25W	57668	NTR25J-E1K8

Component No.	Tektronix Part No.	Serial/Assembly No. Effective Dscont	Name & Description	Mfr. Code	Mfr. Part No.
A1R589	321-0318-00		RES, FXD, FILM:20.0K OHM, 1%, 0.125W, TC=TO	19701	5033ED20K00F
A1R590	321-0205-00		RES, FXD, FILM:1.33K OHM, 1%, 0.125W, TC=TO	19701	5033ED1K330F
A1R775	315-0181-00		RES, FXD, FILM:180 OHM, 5%, 0.25W	57668	NTR25J-E180E
A1R776	315-0102-00		RES, FXD, FILM:1K OHM, 5%, 0.25W	57668	NTR25JE01K0
A1R778	321-0396-00		RES, FXD, FILM:130K OHM, 1%, 0.125W, TC=TO	07716	CEAD13002F
A1R779	321-0306-00		RES, FXD, FILM:15.0K OHM, 1%, 0.125W, TC=TO	19701	5033ED15J00F
A1R780	315-0510-00		RES, FXD, FILM:51 OHM, 5%, 0.25W	19701	5043CX51R00J
A1R781	321-0146-00		RES, FXD, FILM:324 OHM, 1%, 0.125W, TC=TO	07716	CEAD324R0F
A1R783	315-0623-00		RES, FXD, FILM:62K OHM, 5%, 0.25W	19701	5043CX62K00J
A1R784	323-0314-00		RES, FXD, FILM:18.2K OHM, 1%, 0.5W, TC=TO	75042	CECT0-1822F
A1R785	323-0314-00		RES, FXD, FILM:18.2K OHM, 1%, 0.5W, TC=TO	75042	CECT0-1822F
A1R786	321-0185-00		RES, FXD, FILM:825 OHM, 1%, 0.125W, TC=TO	07716	CEAD825R0F
A1R787	315-0101-00		RES, FXD, FILM:100 OHM, 5%, 0.25W	57668	NTR25J-E 100E
A1R788	321-0249-00		RES, FXD, FILM:3.83K OHM, 1%, 0.125W, TC=TO	19701	5033ED3K83F
A1R789	315-0510-00		RES, FXD, FILM:51 OHM, 5%, 0.25W	19701	5043CX51R00J
A1R790	315-0510-00		RES, FXD, FILM:51 OHM, 5%, 0.25W	19701	5043CX51R00J
A1R791	321-0139-00		RES, FXD, FILM:274 OHM, 1%, 0.125W, TC=TO	07716	CEAD274R0F
A1R792	321-0135-00		RES, FXD, FILM:249 OHM, 1%, 0.125W, TC=TO	07716	CEAD249R0F
A1R793	315-0623-00		RES, FXD, FILM:62K OHM, 5%, 0.25W	19701	5043CX62K00J
A1R794	323-0314-00		RES, FXD, FILM:18.2K OHM, 1%, 0.5W, TC=TO	75042	CECT0-1822F
A1R795	323-0314-00		RES, FXD, FILM:18.2K OHM, 1%, 0.5W, TC=TO	75042	CECT0-1822F
A1R796	321-0207-00		RES, FXD, FILM:1.40K OHM, 1%, 0.125W, TC=TO	19701	5033ED1K400F
A1R797	315-0101-00		RES, FXD, FILM:100 OHM, 5%, 0.25W	57668	NTR25J-E 100E
A1R798	321-0249-00		RES, FXD, FILM:3.83K OHM, 1%, 0.125W, TC=TO	19701	5033ED3K83F
A1R799	315-0510-00		RES, FXD, FILM:51 OHM, 5%, 0.25W	19701	5043CX51R00J
A1R804	315-0102-00		RES, FXD, FILM:1K OHM, 5%, 0.25W	57668	NTR25JE01K0
A1R805	315-0562-00		RES, FXD, FILM:5.6K OHM, 5%, 0.25W	57668	NTR25J-E05K6
A1R818	315-0272-00		RES, FXD, FILM:2.7K OHM, 5%, 0.25W	57668	NTR25J-E02K7
A1R819	315-0103-00		RES, FXD, FILM:10K OHM, 5%, 0.25W	19701	5043CX10K00J
A1R820	315-0362-00		RES, FXD, FILM:3.6K OHM, 5%, 0.25W	19701	5043CX3K600J
A1R822	321-0361-00		RES, FXD, FILM:56.2K OHM, 1%, 0.125W, TC=TO	07716	CEAD56201F
A1R823	315-0472-00		RES, FXD, FILM:4.7K OHM, 5%, 0.25W	57668	NTR25J-E04K7
A1R825	315-0101-00		RES, FXD, FILM:100 OHM, 5%, 0.25W	57668	NTR25J-E 100E
A1R828	315-0203-00		RES, FXD, FILM:20K OHM, 5%, 0.25W	57668	NTR25J-E 20K
A1R830	321-0205-00		RES, FXD, FILM:1.33K OHM, 1%, 0.125W, TC=TO	19701	5033ED1K330F
A1R832	321-0223-00		RES, FXD, FILM:2.05K OHM, 1%, 0.125W, TC=TO	19701	5033ED2K05F
A1R834	315-0101-00		RES, FXD, FILM:100 OHM, 5%, 0.25W	57668	NTR25J-E 100E
A1R835	321-0233-00		RES, FXD, FILM:2.61K OHM, 1%, 0.125W, TC=TO	07716	CEAD26100F
A1R836	315-0102-00		RES, FXD, FILM:1K OHM, 5%, 0.25W	57668	NTR25JE01K0
A1R840	315-0511-00		RES, FXD, FILM:510 OHM, 5%, 0.25W	19701	5043CX510R0J
A1R841	321-0344-00		RES, FXD, FILM:37.4K OHM, 1%, 0.125W, TC=TO	19701	5033ED 37K40F
A1R842	315-0241-00		RES, FXD, FILM:240 OHM, 5%, 0.25W	19701	5043CX240R0J
A1R843	321-0344-00		RES, FXD, FILM:37.4K OHM, 1%, 0.125W, TC=TO	19701	5033ED 37K40F
A1R844	315-0104-00		RES, FXD, FILM:100K OHM, 5%, 0.25W	57668	NTR25J-E100K
A1R845	315-0472-00		RES, FXD, FILM:4.7K OHM, 5%, 0.25W	57668	NTR25J-E04K7
A1R849	315-0102-00		RES, FXD, FILM:1K OHM, 5%, 0.25W	57668	NTR25JE01K0
A1R850	315-0102-00		RES, FXD, FILM:1K OHM, 5%, 0.25W	57668	NTR25JE01K0
A1R851	311-2367-00		RES, VAR, NONW: TRMR, 22K OHM, 0.5W	K8788	TC10-LV10-22K/A
A1R852	315-0103-00		RES, FXD, FILM:10K OHM, 5%, 0.25W	19701	5043CX10K00J
A1R853	315-0204-00		RES, FXD, FILM:200K OHM, 5%, 0.25W	19701	5043CX200K0J
A1R854	315-0472-00		RES, FXD, FILM:4.7K OHM, 5%, 0.25W	57668	NTR25J-E04K7
A1R855	315-0202-00		RES, FXD, FILM:2K OHM, 5%, 0.25W	57668	NTR25J-E 2K
A1R858	315-0511-00		RES, FXD, FILM:510 OHM, 5%, 0.25W	19701	5043CX510R0J
A1R860	315-0625-00		RES, FXD, FILM:6.2M OHM, 5%, 0.25W	01121	CB6255
A1R870	311-2358-00		RES, VAR, NONW: TRMR, 100K OHM, 0.5W	K8788	TC10-LV10-100K/A
A1R871	311-2358-00		RES, VAR, NONW: TRMR, 100K OHM, 0.5W	K8788	TC10-LV10-100K/A
A1R874	315-0513-00		RES, FXD, FILM:51K OHM, 5%, 0.25W	57668	NTR25J-E51K0
A1R875	315-0513-00		RES, FXD, FILM:51K OHM, 5%, 0.25W	57668	NTR25J-E51K0

Replaceable Electrical Parts - 2205 Service

Component No.	Tektronix Part No.	Serial/Assembly No. Effective Discnt	Name & Description	Mfr. Code	Mfr. Part No.
A1R888	301-0514-00		RES,FXD,FILM:510K OHM,5%,0.5W	19701	5053CX510K0J
A1R889	301-0514-00		RES,FXD,FILM:510K OHM,5%,0.5W	19701	5053CX510K0J
A1R890	301-0514-00		RES,FXD,FILM:510K OHM,5%,0.5W	19701	5053CX510K0J
A1R891	301-0514-00		RES,FXD,FILM:510K OHM,5%,0.5W	19701	5053CX510K0J
A1R892	301-0514-00		RES,FXD,FILM:510K OHM,5%,0.5W	19701	5053CX510K0J
A1R894	315-0753-00		RES,FXD,FILM:75K OHM,5%,0.25W	57668	NTR25J-E75K0
A1R899	315-0102-00		RES,FXD,FILM:1K OHM,5%,0.25W	57668	NTR25JE01K0
A1R900	315-0105-00		RES,FXD,FILM:1M OHM,5%,0.25W	19701	5043CX1M000J
A1R901	315-0103-00		RES,FXD,FILM:10K OHM,5%,0.25W	19701	5043CX10K00J
A1R910	308-0499-00		RES,FXD,WV:0.5 OHM,10%,2.5W,AXIAL	14193	SA31 R500K
A1R911	315-0102-00		RES,FXD,FILM:1K OHM,5%,0.25W	57668	NTR25JE01K0
A1R912	315-0102-00		RES,FXD,FILM:1K OHM,5%,0.25W	57668	NTR25JE01K0
A1R913	315-0102-00		RES,FXD,FILM:1K OHM,5%,0.25W	57668	NTR25JE01K0
A1R914	315-0202-00		RES,FXD,FILM:2K OHM,5%,0.25W	57668	NTR25J-E 2K
A1R915	315-0512-00		RES,FXD,FILM:5.1K OHM,5%,0.25W	57668	NTR25J-E05K1
A1R916	311-2364-00		RES,VAR,NONWV:TRMR,4.7K OHM,0.5W	K8788	TC10-LV10-4K7/A
A1R917	315-0513-00		RES,FXD,FILM:51K OHM,5%,0.25W	57668	NTR25J-E51K0
A1R918	321-0344-00		RES,FXD,FILM:37.4K OHM,1%,0.125W,TC=TO	19701	5033ED 37K40F
A1R919	315-0102-00		RES,FXD,FILM:1K OHM,5%,0.25W	57668	NTR25JE01K0
A1R920	315-0303-00		RES,FXD,FILM:30K OHM,5%,0.25W	19701	5043CX30K00J
A1R922	315-0202-00		RES,FXD,FILM:2K OHM,5%,0.25W	57668	NTR25J-E 2K
A1R926	315-0103-00		RES,FXD,FILM:10K OHM,5%,0.25W	19701	5043CX10K00J
A1R927	315-0106-00		RES,FXD,FILM:10M OHM,5%,0.25W	01121	CB1065
A1R928	315-0103-00		RES,FXD,FILM:10K OHM,5%,0.25W	19701	5043CX10K00J
A1R929	315-0103-00		RES,FXD,FILM:10K OHM,5%,0.25W	19701	5043CX10K00J
A1R930	315-0511-00		RES,FXD,FILM:510 OHM,5%,0.25W	19701	5043CX510R0J
A1R931	315-0822-00		RES,FXD,FILM:8.2K OHM,5%,0.25W	19701	5043CX8K200J
A1R932	315-0822-00		RES,FXD,FILM:8.2K OHM,5%,0.25W	19701	5043CX8K200J
A1R933	315-0241-00		RES,FXD,FILM:240 OHM,5%,0.25W	19701	5043CX240R0J
A1R934	315-0303-00		RES,FXD,FILM:30K OHM,5%,0.25W	19701	5043CX30K00J
A1R935	315-0303-00		RES,FXD,FILM:30K OHM,5%,0.25W	19701	5043CX30K00J
A1R936	315-0512-00		RES,FXD,FILM:5.1K OHM,5%,0.25W	57668	NTR25J-E05K1
A1R939	315-0303-00		RES,FXD,FILM:30K OHM,5%,0.25W	19701	5043CX30K00J
A1R940	315-0102-00		RES,FXD,FILM:1K OHM,5%,0.25W	57668	NTR25JE01K0
A1R941	315-0241-00		RES,FXD,FILM:240 OHM,5%,0.25W	19701	5043CX240R0J
A1R942	315-0510-00		RES,FXD,FILM:51 OHM,5%,0.25W	19701	5043CX51R00J
A1R943	315-0303-00		RES,FXD,FILM:30K OHM,5%,0.25W	19701	5043CX30K00J
A1R944	315-0102-00		RES,FXD,FILM:1K OHM,5%,0.25W	57668	NTR25JE01K0
A1R945	315-0241-00		RES,FXD,FILM:240 OHM,5%,0.25W	19701	5043CX240R0J
A1R946	315-0510-00		RES,FXD,FILM:51 OHM,5%,0.25W	19701	5043CX51R00J
A1R947	315-0241-00		RES,FXD,FILM:240 OHM,5%,0.25W	19701	5043CX240R0J
A1R948	315-0241-00		RES,FXD,FILM:240 OHM,5%,0.25W	19701	5043CX240R0J
A1R949	307-0106-00		RES,FXD,CMPNSN:4.7 OHM,5%,0.25W	01121	CB 4765
A1R955	315-0511-00		RES,FXD,FILM:510 OHM,5%,0.25W	19701	5043CX510R0J
A1R956	315-0103-00		RES,FXD,FILM:10K OHM,5%,0.25W	19701	5043CX10K00J
A1R957	315-0103-00		RES,FXD,FILM:10K OHM,5%,0.25W	19701	5043CX10K00J
A1R958	315-0303-00		RES,FXD,FILM:30K OHM,5%,0.25W	19701	5043CX30K00J
A1R970	301-0102-00		RES,FXD,CMPNSN:1K OHM,5%,0.50W	19701	5053CX1K000J
A1R971	301-0101-00		RES,FXD,FILM:100 OHM,5%,0.5W	01121	EB1015
A1R972	315-0512-00		RES,FXD,FILM:5.1K OHM,5%,0.25W	57668	NTR25J-E05K1
A1R977	315-0303-00		RES,FXD,FILM:30K OHM,5%,0.25W	19701	5043CX30K00J
A1R978	315-0512-00		RES,FXD,FILM:5.1K OHM,5%,0.25W	57668	NTR25J-E05K1
A1R979	315-0301-00		RES,FXD,FILM:300 OHM,5%,0.25W	57668	NTR25J-E300E
A1R980	315-0512-00		RES,FXD,FILM:5.1K OHM,5%,0.25W	57668	NTR25J-E05K1
A1R981	315-0513-00		RES,FXD,FILM:51K OHM,5%,0.25W	57668	NTR25J-E51K0
A1R982	315-0512-00		RES,FXD,FILM:5.1K OHM,5%,0.25W	57668	NTR25J-E05K1
A1R983	301-0102-00		RES,FXD,CMPNSN:1K OHM,5%,0.50W	19701	5053CX1K000J
A1R984	301-0102-00		RES,FXD,CMPNSN:1K OHM,5%,0.50W	19701	5053CX1K000J

Component No.	Tektronix Part No.	Serial/Assembly No. Effective Discont	Name & Description	Mfr. Code	Mfr. Part No.
A1R985	315-0303-00		RES,FXD,FILM:30K OHM,5%,0.25W	19701	5043CX30K00J
A1R986	315-0272-00		RES,FXD,FILM:2.7K OHM,5%,0.25W	57668	NTR25J-E02K7
A1R987	315-0272-00		RES,FXD,FILM:2.7K OHM,5%,0.25W	57668	NTR25J-E02K7
A1R988	315-0303-00		RES,FXD,FILM:30K OHM,5%,0.25W	19701	5043CX30K00J
A1R989	315-0103-00		RES,FXD,FILM:10K OHM,5%,0.25W	19701	5043CX10K00J
A1R990	301-0102-00		RES,FXD,CMPSN:1K OHM,5%,0.50W	19701	5053CX1K000J
A1R991	301-0102-00		RES,FXD,CMPSN:1K OHM,5%,0.50W	19701	5053CX1K000J
A1R992	301-0102-00		RES,FXD,CMPSN:1K OHM,5%,0.50W	19701	5053CX1K000J
A1R995	301-0103-02		RES,FXD,CMPSN:10K OHM,5%,0.5W	01121	EB1035
A1T902	120-1788-00		XFMR,PWR,STPON:HIGH FREQUENCY,HIGH VOLTAGE	80009	120-1788-00
A1U130	156-0534-00		MICROCKT,LINER:DUAL DIFF AMPL	02735	CA3102E-98
A1U180	156-0534-00		MICROCKT,LINER:DUAL DIFF AMPL	02735	CA3102E-98
A1U225	156-0067-00		MICROCKT,LINER:BIPOLAR,OPNL AMPL	04713	MC1741CP1
A1U300	156-2988-00		MICROCKT,DGTL:CMOS,QUAD 2 IP NOR	K5856	CD4001BE
A1U304	156-2986-00		MICROCKT,DGTL:CMOS,QUAD 4 IP NOR	K5856	CD4002BE
A1U310	156-2956-00		MICROCKT,LINER:DUAL,INDEP PIFF AMPL	K5856	CA 3054
A1U335	156-2956-00		MICROCKT,LINER:DUAL,INDEP PIFF AMPL	K5856	CA 3054
A1U380	156-2902-00		MICROCKT,LINER:	K5856	CA 3046
A1U415	156-2902-00		MICROCKT,LINER:	K5856	CA 3046
A1U425	156-0853-00		MICROCKT,LINER:OPNL AMPL,DUAL	04713	LM358N
A1U460	156-2956-00		MICROCKT,LINER:DUAL,INDEP PIFF AMPL	K5856	CA 3054
A1U480	156-0205-03		MICROCKT,DGTL:ECL,QUAD 2-INPUT NOR GATE	04713	MC10102 L OR P
A1U500	156-1335-00		MICROCKT,DGTL:LSTTL,DUAL RETRIGGERABLE RESE TTABLE MONOSTABLE MV,SCRN	80009	156-1335-00
A1U520	156-0205-03		MICROCKT,DGTL:ECL,QUAD 2-INPUT NOR GATE	04713	MC10102 L OR P
A1U530	156-1639-00		MICROCKT,DGTL:ECL,DUAL D MA-SLAVE FF	04713	MC10H131(P OR L)
A1U537	156-0721-02		MICROCKT,DGTL:QUAD ST 2-INP NAND GATES	80009	156-0721-02
A1U540	156-0388-03		MICROCKT,DGTL:DUAL D FLIP-FLOP,SCRN	80009	156-0388-03
A1U550	156-0205-03		MICROCKT,DGTL:ECL,QUAD 2-INPUT NOR GATE	04713	MC10102 L OR P
A1U560	156-2902-00		MICROCKT,LINER:	K5856	CA 3046
A1U570	156-1639-00		MICROCKT,DGTL:ECL,DUAL D MA-SLAVE FF	04713	MC10H131(P OR L)
A1U580	156-0853-00		MICROCKT,LINER:OPNL AMPL,DUAL	04713	LM358N
A1U910	156-0853-00		MICROCKT,LINER:OPNL AMPL,DUAL	04713	LM358N
A1U920	156-1126-00		MICROCKT,LINER:VOLTAGE COMPARATOR	01295	LM311P
A1U930	156-1408-02		MICROCKT,LINER:TIMER	01295	TLC555CP
A1U940	156-0366-00		MICROCKT,DGTL:DUAL D FLIP-FLOP	02735	CD4013BF
A1VR776	152-0217-00		SEMICON DVC,DI:ZEN,SI,8.2V,5%,0.4W,DO-7	04713	SZG20
A1VR792	152-0647-00		SEMICON DVC,DI:ZENER,SI,6.8V,5%,400MW,DO-7	04713	1N957B
A1VR915	152-0647-00		SEMICON DVC,DI:ZENER,SI,6.8V,5%,400MW,DO-7	04713	1N957B
A1VR925	152-0278-00		SEMICON DVC,DI:ZEN,SI,3V,5%,0.4W,DO-7	80009	152-0278-00
A1VR932	152-0217-00		SEMICON DVC,DI:ZEN,SI,8.2V,5%,0.4W,DO-7	04713	SZG20
A1VR933	152-0217-00		SEMICON DVC,DI:ZEN,SI,8.2V,5%,0.4W,DO-7	04713	SZG20
A1VR982	152-0571-00		SEMICON DVC,DI:ZEN,SI,16V,5%,0.4W,DO-7	04713	SZG35014KIRL
A1VR985	152-0278-00		SEMICON DVC,DI:ZEN,SI,3V,5%,0.4W,DO-7	80009	152-0278-00
A1VR988	152-0278-00		SEMICON DVC,DI:ZEN,SI,3V,5%,0.4W,DO-7	80009	152-0278-00
A1W30	174-0640-00		CA ASSY,SP,ELEC:4,26 AWG,135MM L,RIBBON	TKOEM	820265804(135mm)
A1W80	174-0640-00		CA ASSY,SP,ELEC:4,26 AWG,135MM L,RIBBON	TKOEM	820265804(135mm)
A1W90	174-0635-00		CA ASSY,SP,ELEC:6,26 AWG,120MM L,RIBBON	TKOEM	82265806(120mm)
A1W224	174-1166-00		CA ASSY,SP,ELEC:2,26 AWG,8.0 L	80009	174-1166-00
A1W225	174-1166-00		CA ASSY,SP,ELEC:2,26 AWG,8.0 L	80009	174-1166-00
A1W500	131-0566-00		BUS,CONDUCTOR:DUMMY RES,0.094 OD X 0.225 L	24546	OMA 07
A1W590	195-3407-00		LEAD,ELECTRICAL:26 AWG,3.0 L,9-3	80009	195-3407-00
A1W701	174-0637-00		CA ASSY,SP,ELEC:6,26 AWG,300MM L,RIBBON	TKOEM	82265806(300mm)
A1W755	174-0640-00		CA ASSY,SP,ELEC:4,26 AWG,135MM L,RIBBON	TKOEM	820265804(135mm)
A1W893	174-0642-00		CA ASSY,SP,ELEC:3,26 AWG,100MM L,RIBBON	TKOEM	82265803(100mm)
A1W903	174-0636-00		CA ASSY,SP,ELEC:3,26 AWG,150MM L,RIBBON	TKOEM	82265803(150mm)
A1W920	131-0566-00		BUS,CONDUCTOR:DUMMY RES,0.094 OD X 0.225 L	24546	OMA 07

Replaceable Electrical Parts - 2205 Service

Component No.	Tektronix Part No.	Serial/Assembly No. Effective Dscont	Name & Description	Mfr. Code	Mfr. Part No.
A1W921	131-0566-00		BUS, CONDUCTOR: DUMMY RES, 0.094 OD X 0.225 L	24546	OMA 07
A1W925	131-0566-00		BUS, CONDUCTOR: DUMMY RES, 0.094 OD X 0.225 L	24546	OMA 07
A1W926	131-0566-00		BUS, CONDUCTOR: DUMMY RES, 0.094 OD X 0.225 L	24546	OMA 07
A1W947	131-0566-00		BUS, CONDUCTOR: DUMMY RES, 0.094 OD X 0.225 L	24546	OMA 07
A1W948	131-0566-00		BUS, CONDUCTOR: DUMMY RES, 0.094 OD X 0.225 L	24546	OMA 07
A1W951	131-0566-00		BUS, CONDUCTOR: DUMMY RES, 0.094 OD X 0.225 L	24546	OMA 07
A1W976	131-0566-00		BUS, CONDUCTOR: DUMMY RES, 0.094 OD X 0.225 L	24546	OMA 07
A1W984	131-0566-00		BUS, CONDUCTOR: DUMMY RES, 0.094 OD X 0.225 L	24546	OMA 07
A1W985	131-0566-00		BUS, CONDUCTOR: DUMMY RES, 0.094 OD X 0.225 L	24546	OMA 07
A1W987	131-0566-00		BUS, CONDUCTOR: DUMMY RES, 0.094 OD X 0.225 L	24546	OMA 07
A1W989	131-0566-00		BUS, CONDUCTOR: DUMMY RES, 0.094 OD X 0.225 L	24546	OMA 07
A1W991	131-0566-00		BUS, CONDUCTOR: DUMMY RES, 0.094 OD X 0.225 L	24546	OMA 07

Component No.	Tektronix Part No.	Serial/Assembly No. Effective Dscnt	Name & Description	Mfr. Code	Mfr. Part No.
A2	671-0390-00		CIRCUIT BD ASSY:TIMEBASE/ATTEN	80009	671-0390-00
A2AT1	260-2409-00		SWITCH,ROTARY:1M OHM,10 POS ATTENUATOR	TK1815	
A2AT51	260-2409-00		SWITCH,ROTARY:1M OHM,10 POS ATTENUATOR	TK1815	
A2C6	283-0000-00		CAP,FXD,CER DI:0.001UF,+100-0%,500V	59660	831-610-Y5U0102P
A2C13	281-0775-01		CAP,FXD,CER DI:0.1UF,20%,50V	04222	SA105E104MAA
A2C30	281-0775-01		CAP,FXD,CER DI:0.1UF,20%,50V	04222	SA105E104MAA
A2C31	281-0812-00		CAP,FXD,CER DI:1000PF,10%,100V	04222	MA101C102KAA
A2C35	281-0812-00		CAP,FXD,CER DI:1000PF,10%,100V	04222	MA101C102KAA
A2C38	281-0812-00		CAP,FXD,CER DI:1000PF,10%,100V	04222	MA101C102KAA
A2C56	283-0000-00		CAP,FXD,CER DI:0.001UF,+100-0%,500V	59660	831-610-Y5U0102P
A2C63	281-0775-01		CAP,FXD,CER DI:0.1UF,20%,50V	04222	SA105E104MAA
A2C80	281-0775-01		CAP,FXD,CER DI:0.1UF,20%,50V	04222	SA105E104MAA
A2C81	281-0812-00		CAP,FXD,CER DI:1000PF,10%,100V	04222	MA101C102KAA
A2C85	281-0775-01		CAP,FXD,CER DI:0.1UF,20%,50V	04222	SA105E104MAA
A2C88	281-0812-00		CAP,FXD,CER DI:1000PF,10%,100V	04222	MA101C102KAA
A2C93	290-1153-00		CAP,FXD,ELCTLT:47UF,+50-10%,10V	K8996	030-24479
A2C94	281-0775-01		CAP,FXD,CER DI:0.1UF,20%,50V	04222	SA105E104MAA
A2C95	281-0775-01		CAP,FXD,CER DI:0.1UF,20%,50V	04222	SA105E104MAA
A2C96	290-1153-00		CAP,FXD,ELCTLT:47UF,+50-10%,10V	K8996	030-24479
A2C97	281-0775-01		CAP,FXD,CER DI:0.1UF,20%,50V	04222	SA105E104MAA
A2C98	281-0775-01		CAP,FXD,CER DI:0.1UF,20%,50V	04222	SA105E104MAA
A2C701	285-1409-00		CAP,FXD,MTLZD:1UF,1%,160V,AXIAL,TUB,MI	TK0ED	ORDER BY DESCR
A2C702	285-1408-00		CAP,FXD,MTLZD:10UF,1%,250V,AXIAL,TUB,MI	TK0ED	ORDER BY DESCR
A2C703	281-0207-00		CAP,VAR,PLASTIC:2-18PF,100V	52769	GXA 18000
A2C704	283-0674-00		CAP,FXD,MICA DI:85PF,1%,500V	00853	D155F850F0
A2C705	281-0813-00		CAP,FXD,CER DI:0.047UF,20%,50V	05397	C412C473M5V2CA
A2C706	281-0775-01		CAP,FXD,CER DI:0.1UF,20%,50V	04222	SA105E104MAA
A2C708	281-0756-00		CAP,FXD,CER DI:2.2PF,+/-0.5PF,200V	04222	SA102A2R20AA
A2C709	281-0775-01		CAP,FXD,CER DI:0.1UF,20%,50V	04222	SA105E104MAA
A2C710	281-0775-01		CAP,FXD,CER DI:0.1UF,20%,50V	04222	SA105E104MAA
A2C712	290-1153-00		CAP,FXD,ELCTLT:47UF,+50-10%,10V	K8996	030-24479
A2C713	290-1153-00		CAP,FXD,ELCTLT:47UF,+50-10%,10V	K8996	030-24479
A2C715	290-1153-00		CAP,FXD,ELCTLT:47UF,+50-10%,10V	K8996	030-24479
A2C722	281-0773-00		CAP,FXD,CER DI:0.01UF,10%,100V	04222	MA201C103KAA
A2C723	290-0183-00		CAP,FXD,ELCTLT:1UF,10%,35V	05397	T3228105K035AS
A2C724	281-0775-01		CAP,FXD,CER DI:0.1UF,20%,50V	04222	SA105E104MAA
A2C727	281-0775-01		CAP,FXD,CER DI:0.1UF,20%,50V	04222	SA105E104MAA
A2C733	281-0758-00		CAP,FXD,CER DI:15PF,20%,100V	04222	SA102A150MAA
A2C755	281-0775-01		CAP,FXD,CER DI:0.1UF,20%,50V	04222	SA105E104MAA
A2C767	281-0786-00		CAP,FXD,CER DI:150PF,10%,100V	04222	MA101A151KAA
A2CR14	152-0141-02		SEMICON DVC,DI:SW,SI,30V,150MA,30V,DO-35	03508	DA2527 (1N4152)
A2CR64	152-0141-02		SEMICON DVC,DI:SW,SI,30V,150MA,30V,DO-35	03508	DA2527 (1N4152)
A2CR758	152-0141-02		SEMICON DVC,DI:SW,SI,30V,150MA,30V,DO-35	03508	DA2527 (1N4152)
A2CR761	152-0141-02		SEMICON DVC,DI:SW,SI,30V,150MA,30V,DO-35	03508	DA2527 (1N4152)
A2CR762	152-0141-02		SEMICON DVC,DI:SW,SI,30V,150MA,30V,DO-35	03508	DA2527 (1N4152)
A2CR769	152-0141-02		SEMICON DVC,DI:SW,SI,30V,150MA,30V,DO-35	03508	DA2527 (1N4152)
A2CR773	152-0141-02		SEMICON DVC,DI:SW,SI,30V,150MA,30V,DO-35	03508	DA2527 (1N4152)
A2CR774	152-0141-02		SEMICON DVC,DI:SW,SI,30V,150MA,30V,DO-35	03508	DA2527 (1N4152)
A2E90	276-0752-00		CORE,EM:FERRITE	34899	2743001111
A2E91	276-0752-00		CORE,EM:FERRITE	34899	2743001111
A2E92	276-0752-00		CORE,EM:FERRITE	34899	2743001111
A2E93	276-0752-00		CORE,EM:FERRITE	34899	2743001111
A2L93	120-1631-00		COIL,RF:FXD,210UH	TK00A	ORDER BY DESCR
A2L96	120-1631-00		COIL,RF:FXD,210UH	TK00A	ORDER BY DESCR
A2L712	120-1631-00		COIL,RF:FXD,210UH	TK00A	ORDER BY DESCR
A2L713	120-1631-00		COIL,RF:FXD,210UH	TK00A	ORDER BY DESCR
A2Q13	151-1054-00		TRANSISTOR:FET,N-CHAN,SI,TO-71	80009	151-1054-00
A2Q14	151-1025-00		TRANSISTOR:FET,N-CHAN,SI,TO-92	04713	SPF3036

Replaceable Electrical Parts - 2205 Service

Component No.	Tektronix Part No.	Serial/Assembly No. Effective Dscnt	Name & Description	Mfr. Code	Mfr. Part No.
A2Q63	151-1054-00		TRANSISTOR:FET,N-CHAN,SI,TO-71	80009	151-1054-00
A2Q64	151-1025-00		TRANSISTOR:FET,N-CHAN,SI,TO-92	04713	SPF3036
A2Q701	151-0424-00		TRANSISTOR:NPN,SI,TO-92	04713	SPS8246
A2Q704	151-1042-00		SEMICOND DVC SE:FET,SI,TO-92 (LOCATIONS A & B)	80009	151-1042-00
A2Q706	151-0736-00		TRANSISTOR:NPN,SI,TO-92	80009	151-0736-00
A2Q725	151-0190-00		TRANSISTOR:NPN,SI,TO-92	80009	151-0190-00
A2Q732	151-0190-00		TRANSISTOR:NPN,SI,TO-92	80009	151-0190-00
A2Q736	151-0190-00		TRANSISTOR:NPN,SI,TO-92	80009	151-0190-00
A2Q737	151-0188-00		TRANSISTOR:PMP,SI,TO-92	80009	151-0188-00
A2Q750	151-0188-00		TRANSISTOR:PMP,SI,TO-92	80009	151-0188-00
A2Q759	151-0188-00		TRANSISTOR:PMP,SI,TO-92	80009	151-0188-00
A2Q760	151-0188-00		TRANSISTOR:PMP,SI,TO-92	80009	151-0188-00
A2R3	315-0330-00		RES,FXD,FILM:33 OHM,5%,0.25W	19701	5043CX33R00J
A2R5	322-0481-01		RES,FXD,FILM:1M OHM,0.5%,0.25W,TC=TO	75042	CEBTO-1004D
A2R6	315-0474-00		RES,FXD,FILM:470K OHM,5%,0.25W	19701	5043CX470K0J92U
A2R13	315-0470-00		RES,FXD,FILM:47 OHM,5%,0.25W	57668	NTR25J-E47E0
A2R14	315-0200-00		RES,FXD,FILM:20 OHM,5%,0.25W	19701	5043CX20R00J
A2R15	315-0200-00		RES,FXD,FILM:20 OHM,5%,0.25W	19701	5043CX20R00J
A2R22	321-0210-00		RES,FXD,FILM:1.50K OHM,1%,0.125W,TC=TO	19701	5033ED1K50F
A2R23	321-0210-00		RES,FXD,FILM:1.50K OHM,1%,0.125W,TC=TO	19701	5033ED1K50F
A2R29	321-0068-00		RES,FXD,FILM:49.9 OHM,0.1%,0.125W,TC=TO	91637	CMF55116649R90F
A2R30	315-0472-00		RES,FXD,FILM:4.7K OHM,5%,0.25W	57668	NTR25J-E04K7
A2R31	315-0101-00		RES,FXD,FILM:100 OHM,5%,0.25W	57668	NTR25J-E 100E
A2R32	315-0472-00		RES,FXD,FILM:4.7K OHM,5%,0.25W	57668	NTR25J-E04K7
A2R33	311-2368-00		RES,VAR,NONMW:TRMR,47K OHM,0.5W	K8788	TC10-LV10-47K/A
A2R35	321-0144-00		RES,FXD,FILM:309 OHM,1%,0.125W,TC=TO	07716	CEAD309ROF
A2R36	315-0101-00		RES,FXD,FILM:100 OHM,5%,0.25W	57668	NTR25J-E 100E
A2R37	315-0102-00		RES,FXD,FILM:1K OHM,5%,0.25W	57668	NTR25JE01K0
A2R38	321-0144-00		RES,FXD,FILM:309 OHM,1%,0.125W,TC=TO	07716	CEAD309ROF
A2R39	315-0242-00		RES,FXD,FILM:2.4K OHM,5%,0.25W	57668	NTR25J-E02K4
A2R41	321-0154-00		RES,FXD,FILM:392 OHM,1%,0.125W,TC=TO	07716	CEAD392ROF
A2R42	315-0333-00		RES,FXD,FILM:33K OHM,5%,0.25W	57668	NTR25J-E33K0
A2R53	315-0330-00		RES,FXD,FILM:33 OHM,5%,0.25W	19701	5043CX33R00J
A2R55	322-0481-01		RES,FXD,FILM:1M OHM,0.5%,0.25W,TC=TO	75042	CEBTO-1004D
A2R56	315-0474-00		RES,FXD,FILM:470K OHM,5%,0.25W	19701	5043CX470K0J92U
A2R63	315-0470-00		RES,FXD,FILM:47 OHM,5%,0.25W	57668	NTR25J-E47E0
A2R64	315-0200-00		RES,FXD,FILM:20 OHM,5%,0.25W	19701	5043CX20R00J
A2R65	315-0200-00		RES,FXD,FILM:20 OHM,5%,0.25W	19701	5043CX20R00J
A2R72	321-0210-00		RES,FXD,FILM:1.50K OHM,1%,0.125W,TC=TO	19701	5033ED1K50F
A2R73	321-0210-00		RES,FXD,FILM:1.50K OHM,1%,0.125W,TC=TO	19701	5033ED1K50F
A2R78	315-0102-00		RES,FXD,FILM:1K OHM,5%,0.25W	57668	NTR25JE01K0
A2R79	321-0068-00		RES,FXD,FILM:49.9 OHM,0.1%,0.125W,TC=TO	91637	CMF55116649R90F
A2R80	315-0472-00		RES,FXD,FILM:4.7K OHM,5%,0.25W	57668	NTR25J-E04K7
A2R81	315-0101-00		RES,FXD,FILM:100 OHM,5%,0.25W	57668	NTR25J-E 100E
A2R82	315-0472-00		RES,FXD,FILM:4.7K OHM,5%,0.25W	57668	NTR25J-E04K7
A2R83	311-2368-00		RES,VAR,NONMW:TRMR,47K OHM,0.5W	K8788	TC10-LV10-47K/A
A2R85	321-0144-00		RES,FXD,FILM:309 OHM,1%,0.125W,TC=TO	07716	CEAD309ROF
A2R86	315-0101-00		RES,FXD,FILM:100 OHM,5%,0.25W	57668	NTR25J-E 100E
A2R87	315-0102-00		RES,FXD,FILM:1K OHM,5%,0.25W	57668	NTR25JE01K0
A2R88	321-0144-00		RES,FXD,FILM:309 OHM,1%,0.125W,TC=TO	07716	CEAD309ROF
A2R91	321-0154-00		RES,FXD,FILM:392 OHM,1%,0.125W,TC=TO	07716	CEAD392ROF
A2R701	307-0780-01		RES,NTWK,FXD,FI:TIMING	80009	307-0780-01
A2R702	322-0519-01		RES,FXD,FILM:2.49M OHM,0.5%,0.25W,TC=TO	07716	CCAD24903D
A2R703	315-0100-00		RES,FXD,FILM:10 OHM,5%,0.25W	19701	5043CX10R00J
A2R704	315-0101-00		RES,FXD,FILM:100 OHM,5%,0.25W	57668	NTR25J-E 100E
A2R705	315-0151-00		RES,FXD,FILM:150 OHM,5%,0.25W	57668	NTR25J-E150E
A2R710	315-0102-00		RES,FXD,FILM:1K OHM,5%,0.25W	57668	NTR25JE01K0

Component No.	Tektronix Part No.	Serial/Assembly No. Effective Dscnt	Name & Description	Mfr. Code	Mfr. Part No.
A2R715	321-0231-00		RES, FXD, FILM: 2.49K OHM, 1%, 0.125W, TC=TO	19701	5033ED2K49F
A2R716	321-0225-00		RES, FXD, FILM: 2.15K OHM, 1%, 0.125W, TC=TO	19701	5033ED2K15F
A2R717	321-0306-00		RES, FXD, FILM: 15.0K OHM, 1%, 0.125W, TC=TO	19701	5033ED15J00F
A2R718	321-0306-00		RES, FXD, FILM: 15.0K OHM, 1%, 0.125W, TC=TO	19701	5033ED15J00F
A2R719	315-0330-00		RES, FXD, FILM: 33 OHM, 5%, 0.25W	19701	5043CX33R00J
A2R720	315-0201-00		RES, FXD, FILM: 200 OHM, 5%, 0.25W	57668	NTR25J-E200E
A2R721	311-2356-00		RES, VAR, NONMW: PNL, 470 OHM, 20%, 0.2W	K8996	2322 50190194
A2R722	311-2361-00		RES, VAR, NONMW: TRMR, 10K OHM, 0.5W	K8788	TC10-LV10-10K/A
A2R723	315-0104-00		RES, FXD, FILM: 100K OHM, 5%, 0.25W	57668	NTR25J-E100K
A2R724	315-0302-00		RES, FXD, FILM: 3K OHM, 5%, 0.25W	57668	NTR25J-E03K0
A2R725	321-0222-00		RES, FXD, FILM: 2.00K OHM, 1%, 0.125W, TC=TO	19701	5033ED2K00F
A2R726	315-0101-00		RES, FXD, FILM: 100 OHM, 5%, 0.25W	57668	NTR25J-E 100E
A2R727	321-0254-00		RES, FXD, FILM: 4.32K OHM, 1%, 0.125W, TC=TO	07716	CEAD43200F
A2R728	315-0392-00		RES, FXD, FILM: 3.9K OHM, 5%, 0.25W	57668	NTR25J-E03K9
A2R729	315-0512-00		RES, FXD, FILM: 5.1K OHM, 5%, 0.25W	57668	NTR25J-E05K1
A2R732	321-0254-00		RES, FXD, FILM: 4.32K OHM, 1%, 0.125W, TC=TO	07716	CEAD43200F
A2R733	321-0231-00		RES, FXD, FILM: 2.49K OHM, 1%, 0.125W, TC=TO	19701	5033ED2K49F
A2R734	315-0272-00		RES, FXD, FILM: 2.7K OHM, 5%, 0.25W	57668	NTR25J-E02K7
A2R735	315-0103-00		RES, FXD, FILM: 10K OHM, 5%, 0.25W	19701	5043CX10K00J
A2R736	311-2363-00		RES, VAR, NONMW: TRMR, 1K OHM, 0.5W	K8788	TC10-LV10-1K/A
A2R737	321-0197-00		RES, FXD, FILM: 1.10K OHM, 1%, 0.125W, TC=TO	07716	CEAD11000F
A2R738	315-0562-00		RES, FXD, FILM: 5.6K OHM, 5%, 0.25W	57668	NTR25J-E05K6
A2R740	321-0273-00		RES, FXD, FILM: 6.81K OHM, 1%, 0.125W, TC=TO	07716	CEAD68100F
A2R741	321-0232-00		RES, FXD, FILM: 2.55K OHM, 1%, 0.125W, TC=TO	19701	5043E02K550F
A2R743	315-0112-00		RES, FXD, FILM: 1.1K OHM, 5%, 0.25W	19701	5043CX1K100J
A2R744	311-2232-00		RES, VAR, NONMW: TRMR, 2K OHM, 20%, 0.5W LINEAR	TK1450	GF06UT 2K
A2R745	315-0681-00		RES, FXD, FILM: 680 OHM, 5%, 0.25W	57668	NTR25J-E680E
A2R756	315-0203-00		RES, FXD, FILM: 20K OHM, 5%, 0.25W	57668	NTR25J-E 20K
A2R757	321-0272-00		RES, FXD, FILM: 6.65K OHM, 1%, 0.125W, TC=TO	19701	5043ED6K650F
A2R758	321-0207-00		RES, FXD, FILM: 1.40K OHM, 1%, 0.125W, TC=TO	19701	5033ED1K400F
A2R761	321-0240-00		RES, FXD, FILM: 3.09K OHM, 1%, 0.125W, TC=TO	07716	CEAD30900F
A2R762	321-0240-00		RES, FXD, FILM: 3.09K OHM, 1%, 0.125W, TC=TO	07716	CEAD30900F
A2R763	321-0207-00		RES, FXD, FILM: 1.40K OHM, 1%, 0.125W, TC=TO	19701	5033ED1K400F
A2R765	315-0623-00		RES, FXD, FILM: 62K OHM, 5%, 0.25W	19701	5043CX62K00J
A2R766	315-0203-00		RES, FXD, FILM: 20K OHM, 5%, 0.25W	57668	NTR25J-E 20K
A2R767	315-0820-00		RES, FXD, FILM: 82 OHM, 5%, 0.25W	57668	NTR25J-E82E0
A2R768	321-0214-00		RES, FXD, FILM: 1.65K OHM, 1%, 0.125W, TC=TO	19701	5033ED1K65F
A2R769	315-0512-00		RES, FXD, FILM: 5.1K OHM, 5%, 0.25W	57668	NTR25J-E05K1
A2R770	321-0214-00		RES, FXD, FILM: 1.65K OHM, 1%, 0.125W, TC=TO	19701	5033ED1K65F
A2R771	321-0133-00		RES, FXD, FILM: 237 OHM, 1%, 0.125W, TC=TO	07716	CEAD237R0F
A2R772	321-0133-00		RES, FXD, FILM: 237 OHM, 1%, 0.125W, TC=TO	07716	CEAD237R0F
A2R773	321-0133-00		RES, FXD, FILM: 237 OHM, 1%, 0.125W, TC=TO	07716	CEAD237R0F
A2R774	321-0133-00		RES, FXD, FILM: 237 OHM, 1%, 0.125W, TC=TO	07716	CEAD237R0F
A2R777	311-2355-00		RES, VAR, NONMW: TRMR, 100 OHM, 20%, 0.5W	K8788	TC10-LV10-100R/A
A2R780	321-0261-00		RES, FXD, FILM: 5.11K OHM, 1%, 0.125W, TC=TO	19701	5033ED5K110F
A2R782	311-2363-00		RES, VAR, NONMW: TRMR, 1K OHM, 0.5W	K8788	TC10-LV10-1K/A
A2S701	260-2408-00		SWITCH, ROTARY: 4 POLE, 22 POS	80009	260-2408-00
A2U30	156-0534-00		MICROCKT, LINEAR: DUAL DIFF AMPL	02735	CA3102E-98
A2U80	156-0534-00		MICROCKT, LINEAR: DUAL DIFF AMPL	02735	CA3102E-98
A2UB3	156-2902-00		MICROCKT, LINEAR:	K5856	CA 3046
A2U715	156-0067-00		MICROCKT, LINEAR: BIPOLAR, OPNL AMPL	04713	MC1741CP1
A2U745	156-2902-00		MICROCKT, LINEAR:	K5856	CA 3046
A2U755	156-2902-00		MICROCKT, LINEAR:	K5856	CA 3046
A2VR704	152-0571-00		SEMICOND DVC, DI: ZEN, SI, 16V, 5%, 0.4W, DO-7	04713	SZG35014K1RL
A2VR710	152-0571-00		SEMICOND DVC, DI: ZEN, SI, 16V, 5%, 0.4W, DO-7	04713	SZG35014K1RL
A2VR719	152-0217-00		SEMICOND DVC, DI: ZEN, SI, 8.2V, 5%, 0.4W, DO-7	04713	SZG20
A2W711	131-0566-00		BUS, CONDUCTOR: DUMMY RES, 0.094 OD X 0.225 L	24546	OMA 07

Replaceable Electrical Parts - 2205 Service

Component No.	Tektronix Part No.	Serial/Assembly No. Effective	Discont	Name & Description	Mfr. Code	Mfr. Part No.
A2W742	131-0566-00			BUS, CONDUCTOR: DUMMY RES, 0.094 OD X 0.225 L	24546	OMA 07
A2W752	131-0566-00			BUS, CONDUCTOR: DUMMY RES, 0.094 OD X 0.225 L	24546	OMA 07

Component No.	Tektronix Part No.	Serial/Assembly No. Effective Dscnt	Name & Description	Mfr. Code	Mfr. Part No.
A3	671-0392-00		CIRCUIT BD ASSY:FRONT PANEL	80009	671-0392-00
A3C2	285-1106-00		CAP,FXD,PLASTIC:0.022UF,20%,600V	14752	230B1F223
A3C52	285-1106-00		CAP,FXD,PLASTIC:0.022UF,20%,600V	14752	230B1F223
A3C377	285-1385-00		CAP,FXD,PLASTIC:43PF,2.5%,630V	K7779	B31063-A6430-H6
A3C378	285-1386-00		CAP,FXD,PLASTIC:390PF,2.5%,630V	K7779	B31063-A6391-H6
A3C383	285-1385-00		CAP,FXD,PLASTIC:43PF,2.5%,630V	K7779	B31063-A6430-H6
A3C392	281-0815-00		CAP,FXD,CER DI:0.027UF,20%,50V	04222	MA205C273MAA
A3CR401	152-0141-02		SEMICON DVC,DI:SW,SI,30V,150MA,30V,DO-35	03508	DA2527 (1N4152)
A3CR534	152-0141-02		SEMICON DVC,DI:SW,SI,30V,150MA,30V,DO-35	03508	DA2527 (1N4152)
A3CR537	152-0141-02		SEMICON DVC,DI:SW,SI,30V,150MA,30V,DO-35	03508	DA2527 (1N4152)
A3CR538	152-0141-02		SEMICON DVC,DI:SW,SI,30V,150MA,30V,DO-35	03508	DA2527 (1N4152)
A3DS370	150-1187-00		LT EMITTING DIO:GREEN	TK00A	LN31GPHLEXLED5GS
A3DS560	150-1187-00		LT EMITTING DIO:GREEN	TK00A	LN31GPHLEXLED5GS
A3R2	315-0105-00		RES,FXD,FILM:1M OHM,5%,0.25W	19701	5043CX1M000J
A3R4	315-0100-00		RES,FXD,FILM:10 OHM,5%,0.25W	19701	5043CX10R00J
A3R52	315-0105-00		RES,FXD,FILM:1M OHM,5%,0.25W	19701	5043CX1M000J
A3R54	315-0100-00		RES,FXD,FILM:10 OHM,5%,0.25W	19701	5043CX10R00J
A3R84	311-2368-00		RES,VAR,NONMW:TRMR,47K OHM,0.5W	K8788	TC10-LV10-47K/A
A3R89	315-0222-00		RES,FXD,FILM:2.2K OHM,5%,0.25W	57668	NTR25J-E02K2
A3R92	315-0333-00		RES,FXD,FILM:33K OHM,5%,0.25W	57668	NTR25J-E33K0
A3R94	315-0333-00		RES,FXD,FILM:33K OHM,5%,0.25W	57668	NTR25J-E33K0
A3R113	321-0251-00		RES,FXD,FILM:4.02K OHM,1%,0.125W,TC=TO	19701	5033ED4K020F
A3R123	311-2366-00		RES,VAR,NONMW:PNL,470 OHM,20%,0.2W	K8996	PP17/000HFAQA234
A3R163	321-0251-00		RES,FXD,FILM:4.02K OHM,1%,0.125W,TC=TO	19701	5033ED4K020F
A3R173	311-2366-00		RES,VAR,NONMW:PNL,470 OHM,20%,0.2W	K8996	PP17/000HFAQA234
A3R365	315-0621-00		RES,FXD,FILM:620 OHM,5%,0.25W	57668	NTR25J-E620E
A3R376	315-0101-00		RES,FXD,FILM:100 OHM,5%,0.25W	57668	NTR25J-E 100E
A3R377	315-0394-00		RES,FXD,FILM:390K OHM,5%,0.25W	57668	NTR25J-E390K
A3R378	315-0433-00		RES,FXD,FILM:43K OHM,5%,0.25W	19701	5043CX43K00J
A3R379	315-0470-00		RES,FXD,FILM:47 OHM,5%,0.25W	57668	NTR25J-E47E0
A3R383	315-0564-00		RES,FXD,FILM:560K OHM,5%,0.25W	19701	5043CX560K0J
A3R426	311-2366-00		RES,VAR,NONMW:PNL,470 OHM,20%,0.2W	K8996	PP17/000HFAQA234
A3R726	311-2366-00		RES,VAR,NONMW:PNL,470 OHM,20%,0.2W	K8996	PP17/000HFAQA234
A3R800	315-0682-00		RES,FXD,FILM:6.8K OHM,5%,0.25W	57668	NTR25J-E06K8
A3R802	311-2359-00		RES,VAR,NONMW:PNL,10K OHM,20%,0.2W	K8996	PP17000HGAA04110
A3R986	311-2364-00		RES,VAR,NONMW:TRMR,4.7K OHM,0.5W	K8788	TC10-LV10-4K7/A
A3R987	315-0201-00		RES,FXD,FILM:200 OHM,5%,0.25W	57668	NTR25J-E200E
A3S90	260-2291-00		SWITCH,SLIDE:DPDT,250MA,100VAC	U3771	607/TK 2 POS
A3S101	260-2293-00		SWITCH,SLIDE:DPDT,250MA,100VAC	U3771	607/TEK 3 POS
A3S201	260-2293-00		SWITCH,SLIDE:DPDT,250MA,100VAC	U3771	607/TEK 3 POS
A3S390	260-2290-00		SWITCH,PUSH:1 BUTTON,1 POLE,MOMENTARY	TK0EA	SKECCAA061A
A3S392	260-2292-00		SWITCH,SLIDE:DPDT,250MA,100VAC	U3771	607/TEK 4 POS
A3S401	260-2292-00		SWITCH,SLIDE:DPDT,250MA,100VAC	U3771	607/TEK 4 POS
A3S460	260-2291-00		SWITCH,SLIDE:DPDT,250MA,100VAC	U3771	607/TK 2 POS
A3S505	260-2290-00		SWITCH,PUSH:1 BUTTON,1 POLE,MOMENTARY	TK0EA	SKECCAA061A
A3S545	260-2293-00		SWITCH,SLIDE:DPDT,250MA,100VAC	U3771	607/TEK 3 POS
A3S550	260-2293-00		SWITCH,SLIDE:DPDT,250MA,100VAC	U3771	607/TEK 3 POS
A3S555	260-2292-00		SWITCH,SLIDE:DPDT,250MA,100VAC	U3771	607/TEK 4 POS
A3S601	260-2291-00		SWITCH,SLIDE:DPDT,250MA,100VAC	U3771	607/TK 2 POS
A3W1	174-0639-00		CA ASSY,SP,ELEC:6.26 AWG,110MM L,RIBBON	TKOEM	82265806(95mm)
A3W2	174-0638-00		CA ASSY,SP,ELEC:6.26 AWG,165MM L,RIBBON	TKOEM	82265806(165mm)
A3W3	174-0639-00		CA ASSY,SP,ELEC:6.26 AWG,110MM L,RIBBON	TKOEM	82265806(95mm)
A3W5	174-0639-00		CA ASSY,SP,ELEC:6.26 AWG,110MM L,RIBBON	TKOEM	82265806(95mm)
A3W6	174-0635-00		CA ASSY,SP,ELEC:6.26 AWG,120MM L,RIBBON	TKOEM	82265806(120mm)
A3W7	174-0638-00		CA ASSY,SP,ELEC:6.26 AWG,165MM L,RIBBON	TKOEM	82265806(165mm)

Replaceable Electrical Parts - 2205 Service

Component No.	Tektronix Part No.	Serial/Assembly No. Effective Dscont	Name & Description	Mfr. Code	Mfr. Part No.
A4	671-0391-00		CIRCUIT BD ASSY:MAIN INPUT	80009	671-0391-00
A4C900	290-1201-00		CAP,FXD,ELCTLT:2200UF,100V,30 X 35MM	TK0900	
A4C903	285-1192-00		CAP,FXD,PPR DI:0.0022 UF,20%,250VAC	TK0515	PME271Y510
A4C904	285-1192-00		CAP,FXD,PPR DI:0.0022 UF,20%,250VAC	TK0515	PME271Y510
A4C905	285-1252-00		CAP,FXD,PLASTIC:0.15UF,10%,250VAC	D5243	F1772-415-2000
A4C907	283-0057-00		CAP,FXD,CER DI:0.1UF,+80-20%,200V	04222	SR306E104ZAA
A4CR901	152-0066-00		SEMICON DVC,DI:RECT,SI,400V,1A,DO-41	05828	GP10G-020
A4CR902	152-0066-00		SEMICON DVC,DI:RECT,SI,400V,1A,DO-41	05828	GP10G-020
A4CR903	152-0066-00		SEMICON DVC,DI:RECT,SI,400V,1A,DO-41	05828	GP10G-020
A4CR904	152-0066-00		SEMICON DVC,DI:RECT,SI,400V,1A,DO-41	05828	GP10G-020
A4J901	131-3905-00		CONN,RCPT,ELEC:PWR,250VAC,6A,CKT BD MT	TK00DY	L2157
A4L901	108-1375-00		COIL,RF:FXD,82UH,1A	TK00A	RL-1218-820K-1A
A4L902	108-1375-00		COIL,RF:FXD,82UH,1A	TK00A	RL-1218-820K-1A
A4P902	-----		(PART OF T901)		
A4Q900	151-0350-00		TRANSISTOR:PMP,SI,TO-92	04713	SPS6700
A4R902	315-0473-00		RES,FXD,FILM:47K OHM,5%,0.25W	57668	NTR25J-E47K0
A4R903	315-0243-00		RES,FXD,FILM:24K OHM,5%,0.25W	57668	NTR25J-E24K0
A4R904	315-0562-00		RES,FXD,FILM:5.6K OHM,5%,0.25W	57668	NTR25J-E05K6
A4R905	315-0104-00		RES,FXD,FILM:100K OHM,5%,0.25W	57668	NTR25J-E100K
A4R906	315-0105-00		RES,FXD,FILM:1M OHM,5%,0.25W	19701	5043CX1M000J
A4R907	315-0510-00		RES,FXD,FILM:51 OHM,5%,0.25W	19701	5043CX51R00J
A4S901	260-1849-05		SWITCH,PUSH:DPDT,4A,250VAC,W/BRACKET	31918	NE-15 SERIES
A4S902	260-2116-00		SWITCH,SLIDE:DPDT,10A,125VAC,LINE SEL	04426	18-000-0019
A4W903	174-0636-00		CA ASSY,SP,ELEC:3,26 AWG,150MM L,RIBBON	TK0EM	82265803 (150mm)

Replaceable Electrical Parts - 2205 Service

Component No.	Tektronix Part No.	Serial/Assembly No. Effective	Dscont	Name & Description	Mfr. Code	Mfr. Part No.
FS901	159-0042-00			FUSE, CARTRIDGE:3AG, 0.75A, 250V, 0.15SEC	75915	312.750
J100	131-0955-00			CONN, RCPT, ELEC:BNC, FEMALE	13511	31-279
J151	131-0955-00			CONN, RCPT, ELEC:BNC, FEMALE	13511	31-279
J300	131-0955-00			CONN, RCPT, ELEC:BNC, FEMALE	13511	31-279
J590	131-3898-00			TERM, FEEDTHRU:0.658 M X 0.75 DIA, BRS, AU PL	K0491	001-1401-041140P
R1	315-0470-00			RES, FXD, FILM:47 OHM, 5%, 0.25W	57668	NTR25J-E47E0
R51	315-0470-00			RES, FXD, FILM:47 OHM, 5%, 0.25W	57668	NTR25J-E47E0
R382	315-0470-00			RES, FXD, FILM:47 OHM, 5%, 0.25W	57668	NTR25J-E47E0
R893	311-2357-00	HK10100	HK11183	RES, VAR, NONMW: PNL, 2.2M OHM, 20%, 0.25W	TK00C	ORDER BY DESCR
R893	311-2444-00	HK11184		RES, VAR, NONMW: TRMR, 2.2, 30%, 0.25W, PLASTIC SI DE ADJ, LINEAR	80009	311-2444-00
T901	120-1787-00			XFMR, PWR, STPDN: LOW FREQUENCY	80009	120-1787-00
V900	154-0929-00			ELECTRON TUBE: CRT, W/TRACE	80009	154-0929-00

SECTION	ACRES	VALUATION	REMARKS
1.000	100.00	100.00	...
2.000	200.00	200.00	...
3.000	300.00	300.00	...
4.000	400.00	400.00	...
5.000	500.00	500.00	...
6.000	600.00	600.00	...
7.000	700.00	700.00	...
8.000	800.00	800.00	...
9.000	900.00	900.00	...
10.000	1000.00	1000.00	...

VERTICAL PREAMP & OUTPUT AMPLIFIER DIAGRAM 2

ASSEMBLY A1											
CIRCUIT NUMBER	SCHEM LOCATION	BOARD LOCATION	CIRCUIT NUMBER	SCHEM LOCATION	BOARD LOCATION	CIRCUIT NUMBER	SCHEM LOCATION	BOARD LOCATION	CIRCUIT NUMBER	SCHEM LOCATION	BOARD LOCATION
C114	2F	2H	O102	1C	1H	R145	2H	1K	R238	3P	10K
C115	3F	1H	O103	3C	1H	R150	9B	3H	R239	4R	10K
C116	2E	2J	O104	1C	2H	R151	11B	3H	R241	6N	8L
C124	2F	1J	O105	3C	1H	R152	8B	3H	R242	4M	8K
C125	3F	1J	O114	1F	2J	R153	10B	2H	R243	7M	8K
C126	3F	1J	O115	3F	1J	R154	9C	3H	R244	3P	10K
C130	2G	2K	O152	8C	3H	R155	10C	2H	R245	3P	9K
C133	6H	4L	O153	11C	3H	R156	6C	3H	R246	3P	9K
C164	9F	3H	O154	8C	3H	R158	9B	3H	R247	5P	11L
C165	10F	2H	O155	11C	2H	R159	10B	3H	R248	7R	3B
C174	9F	2J	O164	8F	3J	R161	10L	3F	R249	6P	10L
C175	10F	2J	O165	11F	2J	R162	10N	2F	R250	8P	9L
C176	10F	2J	O202	5K	2K	R164	9E	3H	R251	8P	9L
C180	9F	3K	O203	6K	2K	R165	10E	2H	R252	8P	9L
C188	11L	3G	O206	5L	2K	R166	9C	3H	R253	2G	2K
C202	10N	2G	O207	6L	2K	R167	10C	2H	R258	10G	3K
C215	5K	3K	O230	5M	8K	R168	8C	3H	R260	10P	7L
C220	8R	8L	O231	6M	8L	R169	11C	2H	R263	6N	9L
C225	7K	1K	O232	7N	9L	R170	9F	3H	R264	4N	9K
C232	7P	10L	O234	4N	9K	R171	10E	2H	R265	8P	9L
C235	4P	10K	O236	8P	11K	R172	9F	3J	R266	3P	9K
C239	6R	11K	O237	7P	11L	R174	10F	2J	R267	7P	10L
C240	5P	11K	O238	3P	11K	R175	9F	3J	R268	3P	10K
C241	5N	8K	O239	4P	11K	R176	9F	3J	R269	5P	10K
C242	4N	9K				R177	9G	3K	R280	5N	8K
C243	7N	9K	R100	1B	1H	R180	9F	3J	R538	5G	5L
C245	7N	8L	R101	3B	1H	R181	10G	2J	R539	7F	5K
C246	6N	8L	R102	1B	1H	R182	6G	5L	R540	5G	5L
C247	5N	8K	R103	3B	1H	R183	6H	4K	R541	6G	5K
C248	4N	9K	R104	2C	2H	R185	10G	3K	R544	6E	6K
C536	6F	6K	R105	3C	1H	R186	8G	2K	R545	6E	6K
C537	9N	6K	R106	2C	1H	R189	6H	4L	R547	5F	6K
C538	5F	5L	R108	2B	1H	R192	8J	2J	R548	5F	6K
C539	7F	5K	R109	2B	1H	R193	9H	3K	R549	5G	6K
C540	9M	3J	R114	2E	2H	R194	9H	2J	R561	5D	6K
C545	6E	6L	R115	3E	1H	R195	10J	3K	R566	5D	5K
C547	5F	6K	R116	1C	2H	R202	5J	2K	R567	6D	8L
C561	6D	6K	R117	3C	1H	R203	6J	2K			
C562	5C	5K	R118	1C	2H	R204	5K	3K	U130	1G	1J
			R119	4C	1H	R206	4K	3L	U180	11G	3J
			R120	2F	2H	R207	7K	3L	U225	10N	1K
CR133	5H	4L	R121	3E	1H	R212	5L	2L	U225	10N	1K
CR136	3H	1K	R122	2F	1J	R213	6L	2L	U537A	6F	6K
CR139	3H	2J	R124	3F	1J	R215	5L	2L	U537B	5F	6K
CR183	7H	4L	R125	2F	2J	R216	4K	2K	U537C	5E	6K
CR186	8G	2K	R126	2F	1J	R217	6K	3K	U537D	5E	6K
CR189	8H	3J	R127	2G	2K	R218	4L	2K	U537	10M	6K
CR285	8P	9L	R130	2G	2J	R219	7L	3K	U540A	6G	5K
CR268	3P	9K	R131	3G	1J	R220	6N	9L	U540	10M	5K
CR539	7E	5G	R132	6G	5L	R221	4N	9K	U560C	5C	5H
			R133	5G	4L	R222	5L	2L			
J1	3E	1F	R135	1G	2K	R223	6L	2L	W30	1B	1G
J2	5C	1E	R136	4G	1K	R225	8K	1L	W80	6B	3G
			R139	5H	4L	R226	8K	1L	W224	5L	2L
L321	3R	10K	R140	6H	3K	R232	6N	8L	W224	6L	2L
L322	7R	10L	R142	2J	1J	R233	5M	8K	W225	5M	7K
			R143	3H	2K	R235	5N	8K	W225	6M	7K
P904	4R	10K	R144	2H	1J	R237	6P	11K			

Partial A1 also shown on diagrams 3, 4, 5, 6, 7 and 8.

ASSEMBLY A3

CIRCUIT NUMBER	SCHEM LOCATION	BOARD LOCATION	CIRCUIT NUMBER	SCHEM LOCATION	BOARD LOCATION	CIRCUIT NUMBER	SCHEM LOCATION	BOARD LOCATION	CIRCUIT NUMBER	SCHEM LOCATION	BOARD LOCATION
CR534	6A	2B	R113	2D	1B	S545	5A	2C	W1	2D	4A
CR537	6B	2B	R123	2E	1B	S550	7A	2B	W2	5C	2A
CR538	7B	2B	R163	10D	1C				W2	9D	2A
			R173	10E	1C						

Partial A3 also shown on diagrams 1, 3, 4, 6 and 8.

TRIGGER DIAGRAM 3

LOOKUP TABLE FOR DIAGRAM 3

ASSEMBLY A1											
CIRCUIT NUMBER	SCHEM LOCATION	BOARD LOCATION	CIRCUIT NUMBER	SCHEM LOCATION	BOARD LOCATION	CIRCUIT NUMBER	SCHEM LOCATION	BOARD LOCATION	CIRCUIT NUMBER	SCHEM LOCATION	BOARD LOCATION
C320	1K	3E	R303	2D	2B	R381	2F	3C	R495	7L	
C321	1J	5D	R304	2E	3C	R389	6C	2B	R496	7M	8I
C322	1H	6B	R305	1B	2C	R394	4M	4D	R497	8M	8E
C380	3G	4C	R306	1B	2C	R395	3M	4D	R498	7M	8I
C381	2F	3C	R308	2B	2B	R396	3H	4C	R532	4G	8I
C387	4C	2B	R309	2D	2C	R400	6F	5C	R542	1C	8I
C389	5B	2B	R310	1K	3E	R401	6G	5C	R543	3B	4I
C401	8G	5C	R311	1J	6D	R402	9F	5B			4I
C402	1L	6C	R312	1H	6B	R403	9G	6A	U300A	3E	2E
C408	8H	6B	R316	5G	4E	R404	9H	6A	U300B	1D	2E
C418	6C	4B	R317	5E	4E	R405	8E	3B	U300C	2C	2E
C431	8C	3B	R318	5H	3E	R406	8H	6B	U300D	1C	2E
C480	2N	5C	R319	5F	4E	R407	8J	6B	U300	2M	2E
C481	7G	6C	R320	5H	3E	R408	8J	6B	U304A	2D	2E
C489	7J	4C	R322	5F	4E	R409	8F	6B	U304B	3E	2C
C490	9H	6A	R323	5G	4E	R410	8F	6B	U304	2N	2C
C495	7L	6D	R325	3F	4D	R411	3E	3C	U310A	4F	4E
C496	7M	6D	R326	3G	4E	R412	6E	4C	U310B	5F	4E
			R329	4F	5E	R413	7D	4B	U310C	4H	4E
CR300	1E	3D	R330	4H	5E	R414	7D	4B	U310D	4G	4E
CR301	2E	2C	R331	5J	3E	R415	6D	4B	U310E	5G	4E
CR302	2E	2C	R332	5M	2E	R416	7C	4B	U310F	4G	4E
CR318	4G	4D	R333	6J	3E	R417	7C	4B	U310	1M	4E
CR344	4K	3D	R334	6L	2E	R418	6C	4B	U335A	4J	2E
CR348	2B	2B	R335	5K	3E	R419	9G	6A	U335B	5K	2E
CR349	2B	2B	R336	6K	3E	R426	8D	3B	U335C	4L	2E
CR381	5B	2B	R337	6L	2E	R427	8D	3B	U335D	4L	2E
CR417	7D	4B	R338	6K	2E	R428	8D	3B	U335E	5L	2E
CR431	8D	3C	R339	3K	3D	R429	7C	3B	U335F	4K	2E
CR450	3D	3C	R340	3L	3E	R430	8C	4A	U335	1M	2E
CR451	4D	3C	R343	5L	3D	R431	1L	6C	U380A	3H	3C
CR452	4B	3B	R344	4J	3E	R432	9D	4B	U380B	3M	3C
			R350	2K	3D	R433	9D	4B	U380C	3J	3C
J3	6B	12B	R351	3J	3D	R435	7D	3C	U380D	2J	3C
			R352	2J	3D	R441	4G	3E	U380E	8D	3C
Q370	4C	2A	R353	3J	3D	R442	4G	3E	U415A	7D	4B
Q371	5C	2A	R354	2J	3D	R443	5K	2E	U415B	7E	4B
Q400	7F	5B	R356	2H	4C	R444	5K	2E	U415C	2G	4B
Q401	7G	5B	R357	2H	3C	R445	7C	5B	U415D	7B	4B
Q410	2F	3C	R358	2J	3D	R446	8C	5A	U415E	9D	4B
Q411	4C	3B	R359	2G	4C	R450	4D	3B	U425A	7B	3A
Q412	5C	2B	R360	2H	4C	R451	8E	4B	U425B	8B	3A
Q415	7D	4B	R361	3C	3B	R480	7G	5C	U425	2M	3A
Q450	5L	2E	R362	3D	3C	R481	7H	6B	U480A	8F	5B
Q451	5J	3E	R363	3D	3C	R482	7H	5C	U480B	9F	5B
Q452	5H	4E	R364	4B	3B	R483	7J	5C	U480C	9G	5B
Q453	5E	4E	R366	4B	3B	R485	7J	5C	U480D	8G	5B
Q465	7E	3C	R367	4D	3B	R486	7K	6C	U480E	9G	5B
Q487	6K	6C	R368	4C	3B	R487	6K	6C	U480F	8F	5B
Q488	7K	5C	R369	5D	3B	R488	7K	6D	U480	1N	5B
Q489	7L	5D	R370	4B	2B	R489	8J	4C	U480A	8L	5C
Q490	8B	3A	R371	5C	2B	R490	7K	6D	U480B	7M	5C
			R372	4C	2B	R491	8K	4C	U480C	7H	5C
R300	1D	4K	R373	5C	2B	R492	7L	6C	U480D	7J	5C
R301	3C	4K	R374	5B	2B	R493	8L	6C	U480	2M	5C
R302	1B	2C	R380	2G	4C						

Partial A1 also shown on diagrams 2, 4, 5, 6, 7 and 8.

ASSEMBLY A3											
CIRCUIT NUMBER	SCHEM LOCATION	BOARD LOCATION	CIRCUIT NUMBER	SCHEM LOCATION	BOARD LOCATION	CIRCUIT NUMBER	SCHEM LOCATION	BOARD LOCATION	CIRCUIT NUMBER	SCHEM LOCATION	BOARD LOCATION
R426	7A	1F	W3	6A	4D						

Partial A3 also shown on diagrams 1, 2, 4, 6 and 8.

WAVEFORMS FOR DIAGRAM 4

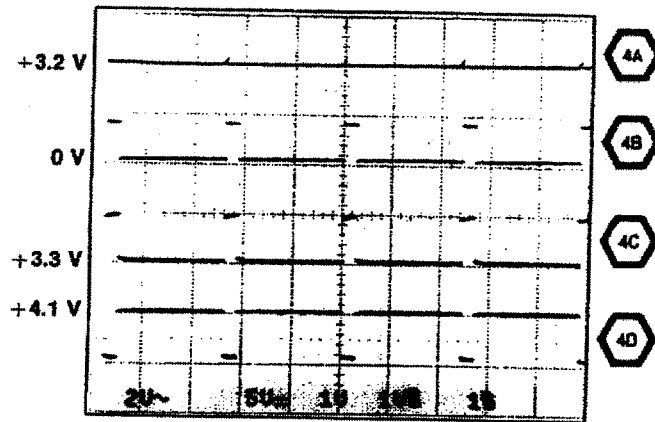

AC Waveforms for 4E through 4N

VOLTS/DIV 0.1 V
 AC-GND-DC AC
 SEC/DIV 5μs

Input signal 4-division, 50 kHz reference sine wave

WAVEFORMS FOR DIAGRAM 4

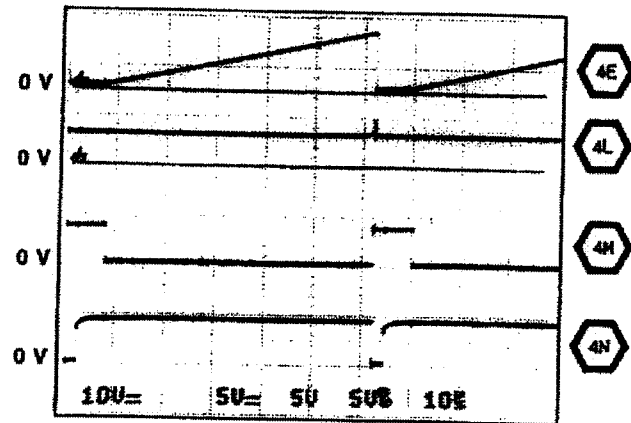
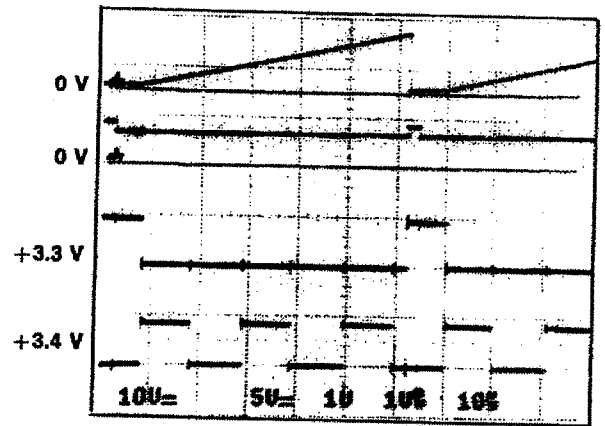
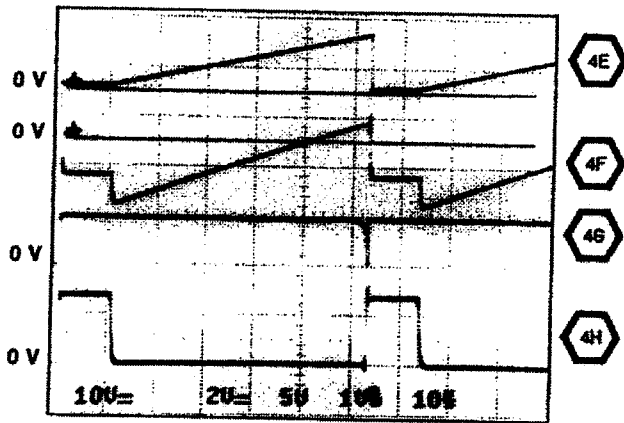

9-14

REPLACEABLE MECHANICAL PARTS

PARTS ORDERING INFORMATION

Replacement parts are available from or through your local Tektronix, Inc. Field Office or representative.

Changes to Tektronix instruments are sometimes made to accommodate improved components as they become available, and to give you the benefit of the latest circuit improvements developed in our engineering department. It is therefore important, when ordering parts, to include the following information in your order: Part number, instrument type or number, serial number, and modification number if applicable.

If a part you have ordered has been replaced with a new or improved part, your local Tektronix, Inc. Field Office or representative will contact you concerning any change in part number.

Change information, if any, is located at the rear of this manual.

ITEM NAME

In the Parts List, an item Name is separated from the description by a colon(:). Because of space limitations, an Item Name may sometimes appear as incomplete. For further Item Name identification, the U.S. Federal Cataloging Handbook H6-1 can be utilized where possible.

FIGURE AND INDEX NUMBERS

Items in this section are referenced by figure and index numbers to the illustrations.

INDENTATION SYSTEM

This mechanical parts list is indented to indicate item relationships. Following is an example of the indentation system used in the description column.

1 2 3 4 5 *Name & Description*

Assembly and/or Component
Attaching parts for Assembly and/or Component

END ATTACHING PARTS

Detail Part of Assembly and/or Component
Attaching parts for Detail Part

END ATTACHING PARTS

Parts of Detail Part
Attaching parts for Parts of Detail Part

END ATTACHING PARTS

Attaching Parts always appear in the same indentation as the item it mounts, while the detail parts are indented to the right. Indented items are part of, and included with, the next higher indentation.

Attaching parts must be purchased separately, unless otherwise specified.

ABBREVIATIONS

Abbreviations conform to American National Standards Institute Y1.1

CROSS INDEX - MFR. CODE NUMBER TO MANUFACTURER

Mfr. Code	Manufacturer	Address	City, State, Zip Code
01536	TEXTRON INC CAMCAR DIV SEMS PRODUCTS UNIT	1818 CHRISTINA ST	ROCKFORD IL 61108
06915	RICHCO PLASTIC CO	5825 N TRIPP AVE	CHICAGO IL 60646-6013
07416	NELSON NAME PLATE CO	3191 CASITAS	LOS ANGELES CA 90039-2410
12327	FREWAY CORP	9301 ALLEN DR	CLEVELAND OH 44125-4632
13511	AMPHENOL CADRE DIV BUNKER RAMO CORP		LOS GATOS CA
16428	COOPER BELDEN ELECTRONIC WIRE AND CA SUB OF COOPER INDUSTRIES INC	NW N ST	RICHMOND IN 47374
57771	STIMPSON CO INC	900 SYLVAN AVE	BAYPORT NY 11705-1012
61935	SCHURTER INC	1016 CLEGG COURT	PETALUMA CA 94952-1152
70903	COOPER BELDEN ELECTRONICS WIRE AND C SUB OF COOPER INDUSTRIES INC	2000 S BATAVIA AVE	GENEVA IL 60134-3325
71400	BUSSMANN DIV OF COOPER INDUSTRIES INC	114 OLD STATE RD PO BOX 14460	ST LOUIS MO 63178
73743	FISCHER SPECIAL MFG CO	111 INDUSTRIAL RD	COLD SPRING KY 41076-9749
75915	LITTELFUSE INC SUB TRACOR INC	800 E NORTHWEST HWY	DES PLAINES IL 60016-3049
78189	ILLINOIS TOOL WORKS INC SHAKEPROOF DIV	ST CHARLES ROAD	ELGIN IL 60120
80009	TEKTRONIX INC	14150 SW KARL BRAUN DR PO BOX 500	BEAVERTON OR 97077-0001
82330	WICKMAN CORP THE	10325 CAPITAL AVE	OAK PARK MI 48237-3103
83385	MICRODOT MFG INC GREER-CENTRAL DIV	3221 W BIG BEAVER RD	TROY MI 48098
83486	ELCO INDUSTRIES INC	1101 SAMUELSON RD	ROCKFORD IL 61101
86113	MICRODOT MFG INC CENTRAL SCREW-KEENE DIV	149 EMERALD ST	KEENE NH 03431-3628
93907	TEXTRON INC CAMCAR DIV	600 18TH AVE	ROCKFORD IL 61108-5181
K1935	JERMYN DISTRIBUTION VESTRY ESTATE	OTFORD ROAD SEVENDAKS	KENT ENGLAND
K2504	RS COMPONENTS LTD	PO BOX 99	CORBY NORTHANTS NN17 9RS ENGLAND
S3109	FELLER	72 Veronica Ave Unit 4	Summerset NJ 08873
TK0174	BADGLEY MFG CO	1620 NE ARGYLE	PORTLAND OR 97211
TK0433	PORTLAND SCREW CO	6520 N BASIN	PORTLAND OR 97217-3920
TK0892	GEROME CORP	OLIVER RD PO BOX 1089	UNIONTOWN PA 15041
TK0EC	CARON ENG. SERVICE	10-11 STATION CLOSE POTTERS BAR	HERTS ENGLAND
TK0EH	HARLOW SPRINGS 1 + 2 ROYDONBURY IND EST THE PINNACLES	HARLOW	ESSEX ENGLAND
TK0EJ	IMP WORKS	ESSEX ROAD HODDESDON	HERTS ENGLAND
TK0EL	MOLBRY LTD	HOLLAND WAY BLANDFORD	DORSET ENGLAND
TK0EO	PLANET JIG & TOOL	BAKER STREET HIGH WYCOMBE	BUCKS ENGLAND
TK0ES	SMALL POWER MACHINE CO INDUSTRIAL ESTATE	BATH ROAD CHIPPENHAM	WILTSHIRE ENGLAND
TK0ET	WARTH INTERNATIONAL CHARLWOODS BUSINESS CENTER	CHARLWOODS ROAD	EAST GRINDSTEAD ENGLAND
TK1319	MORELLIS Q & D PLASTICS	1812 16-TH AVE	FOREST GROVE OR 97116
TK1336	PARSONS MFG CORP	1055 OBRIEN	MENLO PARK CA 94025
TK1373	PATELEC-CEM (ITALY)	10156 TORINO	VAICENTALLO 62/45S ITALY
TK2165	TRIQUEST CORP	3000 LEWIS AND CLARK HWY	VANCOUVER WA 98661-2999

Fig. & Index No.	Tektronix Part No.	Serial/Assembly No.		Qty	12345 Name & Description	Mfr.	
		Effective	Discort			Code	Mfr. Part No.
1-1	426-1765-02			1	FRAME,CRT:POLYCARBONATE,GRAY ATTACHING PARTS	TK2165	ORDER BY DESCR
-2	211-0690-01			2	SCREW,MACHINE:6-32 X 0.875 PNH,SST END ATTACHING PARTS	86113	ORDER BY DESCR
-3	337-2775-00			1	SHLD,IMPLOSION:FILTER,BLUE 2211/2213/2215	80009	337-2775-00
-4	348-0660-00			4	CUSHION,CRT:POLYURETHANE	80009	348-0660-00
-5	366-0636-00			5	KNOB:GRAY,10MM X 12MM H	TK0EJ	ORDER BY DESCR
-6	384-1575-00			1	EXTENSION SHAFT:8.805 L,W/KNOB,PLASTIC	80009	384-1575-00
-7	358-0550-00			1	BUSHING,SHAFT:0.15 ID X 0.488 L,PLSTC	TK2165	ORDER BY DESCR
-8	366-1480-03			1	PUSH BUTTON:BLACK,OFF	80009	366-1480-03
-9	384-1364-00			1	EXTENSION SHAFT:10.818 L X 0.187 SQ,NYL,BLK	TK2165	ORDER BY DESCR
-10	331-0498-00			2	DIAL,CONTROL:32MM X 3.75MM,MKD 1 THRU 50	TK0EJ	ORDER BY DESCR
-11	210-1436-00			2	WASHER,FLAT:9.4MM ID X 12.5MM OD X 2MM THK, ALUMINUM	TK0EL	ORDER BY DESCR
-12	366-0640-00			3	KNOB:GRAY,CAL W/ARROW,10MM X 2MM X 12MM H	TK0ES	ORDER BY DESCR
-13	331-0499-00			1	DIAL,CONTROL:32MM X 3.75MM,MKD 2 X LINES	TK0EJ	ORDER BY DESCR
-14	366-0635-00			2	PUSH BUTTON:GRAY,4.45MM X 7.75MM X	TK0EJ	ORDER BY DESCR
-15	-----			1	TERM,FEEDTHRU:(SEE J590 REPL)		
-16	-----			3	CONN,RCPT,ELEC:BNC,FEMALE (SEE J100,J151,J300 REPL)		
-17	210-0255-00			3	TERMINAL,LUG:0.391 ID,LOCKING,BRS CD PL	12327	ORDER BY DESCR
-18	386-5483-00			1	SUBPANEL,FRONT:	TK0EJ	ORDER BY DESCR
-19	333-3565-00			1	PANEL,FRONT:	80009	333-3565-00
-20	334-7234-00			1	MARKER,IDENT:MARKED VOLTAGE/FUSE SELECT	80009	334-7234-00
-21	334-7088-00			1	MARKER,IDENT:MARKED CAUTION	80009	334-7088-00
-22	200-3335-01			1	COVER,REAR: ATTACHING PARTS	80009	200-3335-01
-23	211-0712-00			2	SCR,ASSEM WSHR:6-32 X 1.25,PNH,STL,TORX END ATTACHING PARTS	01536	ORDER BY DESCR
-24	343-1278-00			2	RTNR,POWER CORD:POLYCARBONATE GRAY	TK2165	ORDER BY DESCR
-25	348-0964-00			2	FOOT,REAR COVER:BLACK,PLASTIC	TK0EJ	ORDER BY DESCR
-26	437-0370-01			1	CABINET,SCOPE: ATTACHING PARTS	TK0EO	ORDER BY DESCR
-27	211-0730-00			4	SCR,ASSEM WSHR:6-32 X 0.375,PNH,STL CD PL, TORX T15 END ATTACHING PARTS	80009	211-0730-00
-28	367-0356-00			1	HANDLE,CARRYING: ATTACHING PARTS	TK0EJ	ORDER BY DESCR
-29	212-0144-00			2	SCREW,TPG,TF:8-16 X 0.562 L,PLASTITE,SPCL HD END ATTACHING PARTS	93907	225-38131-012
-30	214-3984-00			2	SPRING,HLCPS:0.71 OD X 12.0MM L,OPEN ENDS	TK0EH	ORDER BY DESCR

Fig. & Index No.	Tektronix Part No.	Serial/Assembly No. Effective	Discnt	Qty	12345 Name & Description	Mfr. Code	Mfr. Part No.
2-1	441-1752-01			1	CHASSIS, SCOPE: FRONT ATTACHING PARTS	TKDEO	ORDER BY DESCR
-2	211-0718-00			2	SCREW, MACHINE: 6-32 X 0.312, FLH, 100 DEG, STL	83486	ORDER BY DESCR
-2.1	213-0882-00			1	SCREW, TPG, TR: 6-32 X 0.437 TAPTITE, PNH, STL END ATTACHING PARTS	83385	ORDER BY DESCR
-3	337-3397-00			1	SHIELD, ELEC: CH1, CH2 SEPARATION	TKDEO	ORDER BY DESCR
-4	407-3714-00			1	BRKT, CRT SPRT: REAR ATTACHING PARTS	80009	407-3714-00
-5	211-0730-00			3	SCR, ASSEM WSHR: 6-32 X 0.375, PNH, STL CD PL, TORX T15 END ATTACHING PARTS	80009	211-0730-00
-6	214-1061-06			1	SPRING, GROUND: CRT SHIELD	80009	214-1061-06
-7	426-1766-00			1	MOUNT, RESILIENT: CRT REAR	80009	426-1766-00
-8	-----			1	SKT, PL-IN ELEK: CRT, 14 PIN, CABLE ASSY (SEE A1P910 REPL)		
-9	337-3468-00	HK10100	HK10499	1	SHIELD, CRT:	80009	337-3468-00
	337-3468-01	HK10500		1	SHIELD, ELEC: 2205 MAGNETIC METAL	TKQ892	ORDER BY DESCR
-10	334-1379-00			1	MARKER, IDENT: MKD HI VACUUM	07416	ORDER BY DESCR
-11	386-5360-00			1	SUPPORT, CKT BD: POLYCARBONATE ATTACHING PARTS	TKOEJ	ORDER BY DESCR
-12	211-0730-00			1	SCR, ASSEM WSHR: 6-32 X 0.375, PNH, STL CD PL, TORX T15	80009	211-0730-00
-12.1	213-0882-00			1	SCREW, TPG, TR: 6-32 X 0.437 TAPTITE, PNH, STL END ATTACHING PARTS	83385	ORDER BY DESCR
-13	-----			1	CIRCUIT BD ASSY: TIMEBASE/ATTEN (SEE A2) ATTACHING PARTS		
-14	211-0730-00			4	SCR, ASSEM WSHR: 6-32 X 0.375, PNH, STL CD PL, TORX T15	80009	211-0730-00
-15	210-0457-00			2	NUT, PL, ASSEM WA: 6-32 X 0.312, STL CD PL END ATTACHING PARTS	78189	511-061800-00
-16	376-0224-01			1	CPLG, SHAFT, RGD: W/213-0153-00	TKOEC	ORDER BY DESCR
-17	384-1714-00			1	EXTENSION SHAFT: 133MM L X 2MM OD, SST	80009	384-1714-00
-18	-----			1	CIRCUIT BD ASSY: FRONT PANEL (SEE A3 REPL) ATTACHING PARTS		
-19	211-0305-00			6	SCR, ASSEM WSHR: 4-40 X 0.437, PNH, STL, CD PL END ATTACHING PARTS	01536	ORDER BY DESCR
-20	337-3365-00			1	SHIELD, ELEC: ATTENUATOR ATTACHING PARTS	TKOEO	ORDER BY DESCR
-21	211-0730-00			3	SCR, ASSEM WSHR: 6-32 X 0.375, PNH, STL CD PL, TORX T15 END ATTACHING PARTS	80009	211-0730-00
-22	129-1105-00			2	SPACER, POST: 23.5MM L, 4-40 BOTH ENDS, AL, HEX	TKOEL	ORDER BY DESCR
	129-1106-00			1	SPACER, POST: 25.4MM L, W 6-32 THD THRU, BRASS, 6.3MM HEX	TKOEL	ORDER BY DESCR
-23	211-0325-00			1	SCR, ASSEM WSHR: 4-40 X 0.25, PNH, STL, TORX T9	01536	ORDER BY DESCR
-24	337-3364-01			2	SHIELD, ELEC: POWER SUPPLY	TKOEJ	ORDER BY DESCR
-25	-----			1	RES, VAR, NOMW: (SEE R893 REPL)		
-26	384-1710-00	HK10100	HK11183	1	EXTENSION SHAFT: 133MM X 7MM OD, W/STEP, 4MM ID	TKOEJ	ORDER BY DESCR
-27	441-1751-02			1	CHASSIS, SCOPE: INNER ATTACHING PARTS	80009	441-1751-02
-29	211-0730-00			2	SCR, ASSEM WSHR: 6-32 X 0.375, PNH, STL CD PL, TORX T15 END ATTACHING PARTS	80009	211-0730-00
-30	-----			1	CIRCUIT BD ASSY: MAIN INPUT (SEE A4 REPL) ATTACHING PARTS		
-31	211-0730-00			4	SCR, ASSEM WSHR: 6-32 X 0.375, PNH, STL CD PL, TORX T15	80009	211-0730-00
-32	211-0730-00			6	SCR, ASSEM WSHR: 6-32 X 0.375, PNH, STL CD PL, TORX T15	80009	211-0730-00
-33	210-0457-00			2	NUT, PL, ASSEM WA: 6-32 X 0.312, STL CD PL END ATTACHING PARTS	78189	511-061800-00
-34	337-3484-00			1	SHIELD, ELEC: MAINS INPUT	80009	337-3484-00
-35	358-0281-00			1	GROMMET, PLASTIC: BLACK U-SHAPED, 0.375 ID	TK1319	N/A
-36	200-3647-00			1	CAP, FUSE: USE W/0.25 X 1.25 FUSE	75915	345-101-020
	200-3648-00			1	CAP, FUSE: USE W/5 X 20MM FUSE	75915	345-121-020
-37	352-0895-00			1	FUSEHOLDER: 15 A, 250V	75915	345-101-010
-38	-----			1	XFMR, PWR, STDN: (SEE T901 REPL) ATTACHING PARTS		

Replaceable Mechanical Parts - 2205 Service

Fig. & Index No.	Tektronix Part No.	Serial/Assembly No. Effective	Discont	Qty	12345 Name & Description	Mfr. Code	Mfr. Part No.
2-39	212-0093-00			4	SCREW, MACHINE: 8-32 X 2.625, HEX HD, STL	83385	ORDER BY DESCR
-40	220-0555-00	HK10100	HK10499	4	NUT, PLAIN, HEX: 8-32 X 0.25 HEX, STL CD PL	TK0433	ORDER BY DESCR
	210-0409-00	HK10500		4	NUT, PLAIN, HEX: 8-32 X 0.312, BRS CD PL	73743	3046-402
	210-0007-00			4	WASHER, LOCK: #8 EXT, 0.02 THK, STL	78189	1108-00-00-0541C
					END ATTACHING PARTS		
-41	361-0561-00			4	SPACER, SLEEVE: 0.95 L X 0.218 ID, AL	80009	361-0561-00
-42	-----			1	CIRCUIT BD ASSY: MAIN (SEE A1 REPL)		
					ATTACHING PARTS		
-43	211-0730-00			5	SCR, ASSEM WSHR: 6-32 X 0.375, PNH, STL CD PL, TORX T15	80009	211-0730-00
-44	210-0457-00			5	NUT, PL, ASSEM WA: 6-32 X 0.312, STL CD PL	78189	511-061800-00
-45	407-3539-00			1	BRACKET, HEAT SK: ALUMINUM	TK0E0	ORDER BY DESCR
					ATTACHING PARTS		
-46	211-0730-00			1	SCR, ASSEM WSHR: 6-32 X 0.375, PNH, STL CD PL, TORX T15	80009	211-0730-00
-47	213-0882-00			1	SCREW, TPG, TR: 6-32 X 0.437 TAPTITE, PNH, STL	83385	ORDER BY DESCR
					END ATTACHING PARTS		
-48	-----			3	TRANSISTOR: (SEE A1Q933, Q942, Q946 REPL)		
					ATTACHING PARTS		
-49	211-0305-00			3	SCR, ASSEM WSHR: 4-40 X 0.437, PNH, STL, CD PL	01536	ORDER BY DESCR
-50	210-0586-00			3	NUT, PL, ASSEM WA: 4-40 X 0.25, STL CD PL	78189	211-041800-00
					END ATTACHING PARTS		
-51	342-0829-00			3	INSULATOR, PLATE: TRANSISTOR, SIL-PAD	TK0ET	ORDER BY DESCR
	342-0804-00			3	INSULATOR, WSHR: 5.6MM OD X 3.0MM ID X 1.6MM THK, NYLON	80009	342-0804-00
-52	214-4112-00			1	HEAT SINK: ALUMINUM, 2205	80009	214-4112-00
					ATTACHING PARTS		
-53	211-0730-00			2	SCR, ASSEM WSHR: 6-32 X 0.375, PNH, STL CD PL, TORX T15	80009	211-0730-00
					END ATTACHING PARTS		
-54	214-4039-00			4	HEAT SINK, XSTR: TO-5, ALUMINUM	K1935	J25-1204
-55	361-1435-00			4	SPACER, XSTR: POLYPROPYLENE, TO-5	K2504	402-175
-56	441-1830-00			1	CHASSIS, SCOPE: REAR, ALUMINUM	80009	441-1830-00
					ATTACHING PARTS		
-57	211-0718-00			2	SCREW, MACHINE: 6-32 X 0.312, FLH, 100 DEG, STL	83486	ORDER BY DESCR
					END ATTACHING PARTS		
-58	134-0202-00			1	PLUG, BUTTON: STEEL	57771	D2587
	334-7256-00			1	MARKER, IDENT: MARKED CAUTION (A10ID139)	80009	334-7256-00
	337-3384-00			7	SHIELD, ELEC: (A10ID49)	TK0EJ	ORDER BY DESCR
	337-3385-00			7	SHIELD, ELEC: (A10ID50)	TK0EJ	ORDER BY DESCR
	337-3422-00			3	SHIELD, ELEC: (A10ID21)	TK0EJ	ORDER BY DESCR
	342-0803-00			2	INSULATOR, WSHR: 6.4MM OD X 2.54MM ID X 4.5MM THK, POLYPROPYLENE (A10ID111)	80009	342-0803-00

Fig. & Index No.	Tektronix Part No.	Serial/Assembly No. Effective	Dscont	Qty	12345 Name & Description	Mfr. Code	Mfr. Part No.
3-							
STANDARD ACCESSORIES							
	070-6717-00			1	MANUAL, TECH: OPERATORS, 2205	80009	070-6717-00
	103-0275-00			2	ADAPTER, CONN: X1 SIGNAL	80009	103-0275-00
	159-0121-00			1	FUSE, CARTRIDGE: DIN, 0.4A, 250V, 5SEC	61935	FSF034.1512
	159-0182-00			1	FUSE, CARTRIDGE: 5 X 20MM, 0.5A, 250V, FAST BLOW	82330	19200 .5A
	159-0032-00	HK10100	HK10499	1	FUSE, CARTRIDGE: 3AG, 0.5A, 250V, SLOW BLOW	71400	MDL 1/2
-1	161-0104-00			1	CABLE ASSY, PWR, :3 WIRE, 98.0 L, W/RTANG CONN	16428	CH8352, FH-8352
-2	343-0003-00			1	CLAMP, LOOP: 0.25 ID, PLASTIC	06915	E4 CLEAR ROUND
-3	211-0721-00			1	SCREW, MACHINE: 6-32 X 0.375, PNH, STL	83486	ORDER BY DESCR
-4	210-0803-00			1	WASHER, FLAT: 0.15 ID X 0.375 OD X 0.032, STL	12327	ORDER BY DESCR
	020-0859-00	HK10100	HK10499	1	COMPONENT KIT: EUROPEAN	80009	020-0859-00
	020-1684-00	HK10500		1	COMPONENT KIT: EUROPEAN POWER CORD ASSY	80009	020-1684-00
-5	161-0104-06			1	.CABLE ASSY, PWR, :3 X 0.75MM SQ, 220V, 98.0 L .(OPTION A1 ONLY)	53109	ORDER BY DESCR
	020-0860-00	HK10100	HK10499	1	COMPONENT KIT: UNITED KINGDOM	80009	020-0860-00
	020-1685-00	HK10500		1	COMPONENT KIT: UNITED KINGDOM PWR CORD AS	80009	020-1685-00
-6	161-0104-07			1	.CABLE ASSY, PWR, :3 X 0.75MM SQ, 240V, 98.0 L .(OPTION A2 ONLY)	TK1373	A25UK-RA
	020-0861-00	HK10100	HK10499	1	COMPONENT KIT: AUSTRALIAN	80009	020-0861-00
	020-1686-00	HK10500		1	COMPONENT KIT: AUSTRALIAN PWR CORD ASSY	80009	020-1686-00
-7	161-0104-05			1	.CABLE ASSY, PWR, :3, 18 AWG, 240V, 98.0 L .(OPTION A3 ONLY)	53109	ORDER BY DESCR
	020-0862-00	HK10100	HK10499	1	COMPONENT KIT: NORTH AMERICAN	80009	020-0862-00
	020-1687-00	HK10500		1	COMPONENT KIT: NORTH AMERICAN PWR CORD AS	80009	020-1687-00
-8	161-0104-08			1	.CABLE ASSY, PWR, :3, 18 AWG, 240V, 98.0 L .(OPTION A4 ONLY)	70903	ORDER BY DESCR
	020-0863-00	HK10100	HK10499	1	COMPONENT KIT: SWISS	80009	020-0863-00
	020-1688-00	HK10500		1	COMPONENT KIT: SWISS POWER CORD ASSY	80009	020-1688-00
-9	161-0167-00			1	.CABLE ASSY, PWR, :3.0 X 0.75, 6A, 240V, 2.5M L .(OPTION A5 ONLY)	53109	ORDER BY DESCR

EACH COMPONENT KIT CONTAINS THE APPROPRIATE POWER CORD, 159-0032-00 FUSE CARTRIDGE, 343-0003-00 LOOP CLAMP, 211-0721-00 SCREW, AND 210-0803-00 WASHER.

OPTIONAL ACCESSORIES

	016-0180-00			1	VISOR, CRT: FOLDING	TK2165	ORDER BY DESCR
	016-0566-00			1	VISOR, CRT:	TK2165	ORDER BY DESCR
	016-0592-00			1	VISOR, CRT:	TK2165	ORDER BY DESCR
	016-0677-02			1	POUCH, ACCESSORY: W/PLATE (OPTION 02)	TK0174	016-0677-02
	016-0785-00			1	ACCESSORY KIT: MOUNTING, 1107 TO 2200	80009	016-0785-00
	016-0792-01			1	CASE, CARRYING: 24.5 X 16.5 X 11.5 (OPTION 1T)	TK1336	ORDER BY DESCR
	016-0819-02			1	ADAPTER, RACK: RACKMOUNT (OPTION 1R)	80009	016-0819-02
	020-1514-00			1	ACCESSORY KIT:	80009	020-1514-00
	070-6716-00			1	MANUAL, TECH: SERVICE, 2205	80009	070-6716-00
	200-3397-00			1	COVER, SCOPE: FRONT (OPTION 02)	80009	200-3397-00
	337-2775-01			1	SHLD, IMPLOSION:	80009	337-2775-01

FIG. 3 ACCESSORIES

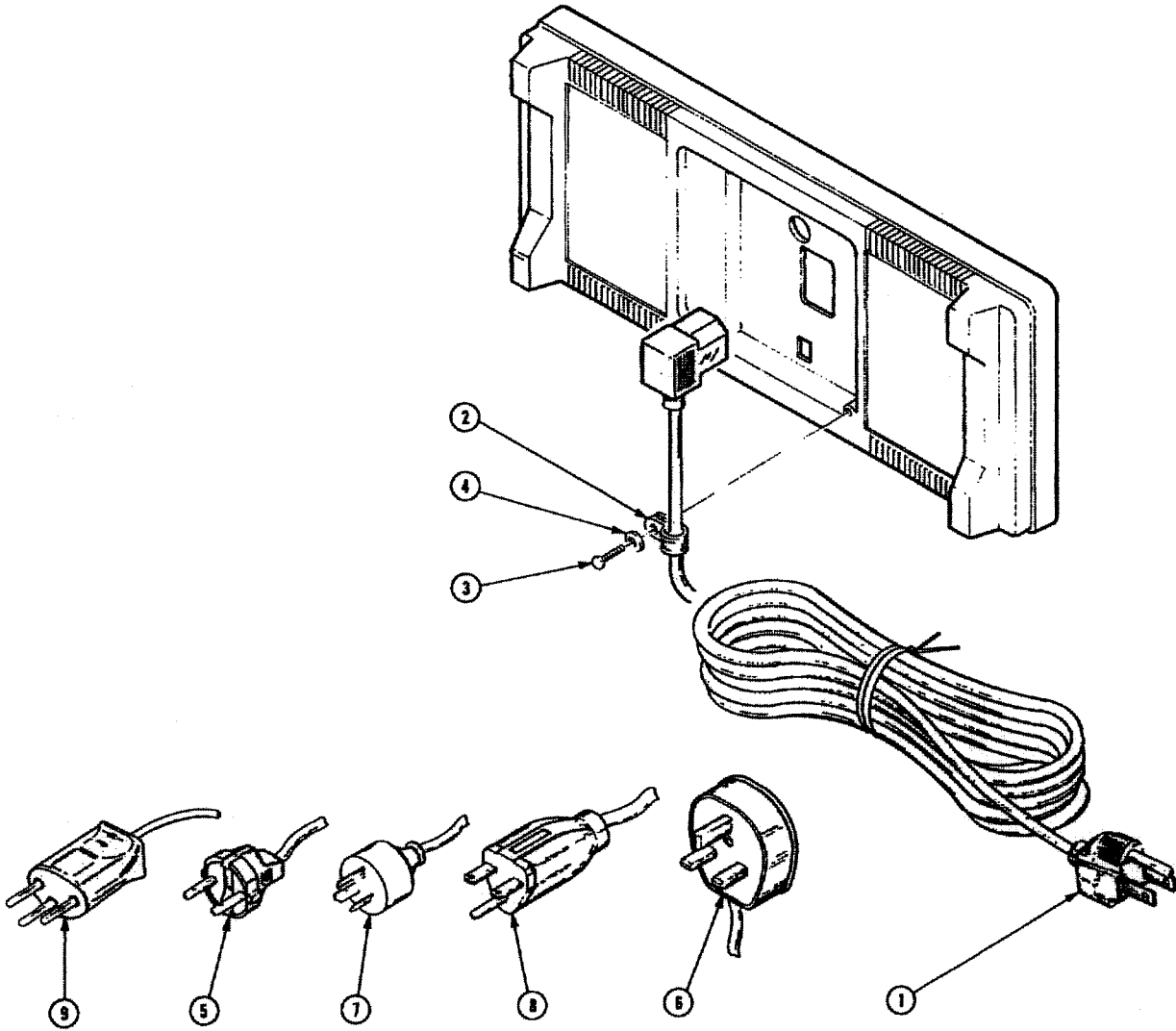

10-8

2205 Service

Manual Insert Status

<u>DATE</u>	<u>CHANGE REFERENCE</u>	<u>STATUS</u>
MAY 8 1988	C1/0588	Effective
FEB 15 1989	M67537	Effective
FEB 20 1989	M67538	Effective
MAY 2 1989	M68110	Effective
JAN 20 1990	M67539	Effective
FEB 2 1990	C1/0290	Effective
MAR 20 1990	C2/0390	Effective
AUG 23 1991	M73789 (REV)	Effective
FEB 5 1992	C3/0292	Effective
JUL 23 1992	M77514	Effective
JUL 23 1992	M74107	Effective
FEB 10 1993	M75549 (REV)	Effective

Date: 5-5-88

Change Reference: C1/0588

Product: 2205 SERVICE

Manual Part No.: 070-6716-00

DESCRIPTION

Product Group 46

EFFECTIVE ALL SERIAL NUMBERS

DIAGRAM CHANGES

DIAGRAM  VERTICAL PREAMP & OUTPUT AMPLIFIER

Change the voltage for the "ON" condition at pin 3 of U225 (location 8K) to $-5.0V$.

DIAGRAM  SWEEP GENERATOR & HORIZONTAL AMPLIFIER

At the Collector of Q780 (location 3L) remove the voltage level of $+14.4V$ from the circuit. The correct voltage level is $+6.2V$.

DIAGRAM  POWER SUPPLY, Z-AXIS, & CRT

At transistors Q941 and Q945 (location 7J) remove the connection shown between the Base and Emitter of each transistor.

DESCRIPTION

Product Group 46

SEE BELOW FOR EFFECTIVE SERIAL NUMBERS:

REPLACEABLE ELECTRICAL PARTS LIST CHANGES

ADD :

A2CR14	151-0141-02	HK10100	SEMICOND DVC,DI: SW,SI,30V,150MA,30V,DO-35
A2CR64	151-0141-02	HK10100	SEMICOND DVC,DI: SW,SI,30V,150MA,30V,DO-35

REPLACEABLE MECHANICAL PARTS LIST CHANGES

CHANGE TO:

2-9	337-3468-01	HK10500	1 SHIELD,CRT:
-----	-------------	---------	---------------

DIAGRAM CHANGES

DIAGRAM 1 VERTICAL ATTENUATORS

Add diodes CR14 and CR64 to pins 2 and 3 of U30 and U80 respectively as shown with the partial schematics. Schematic locations are 2G and 6G.

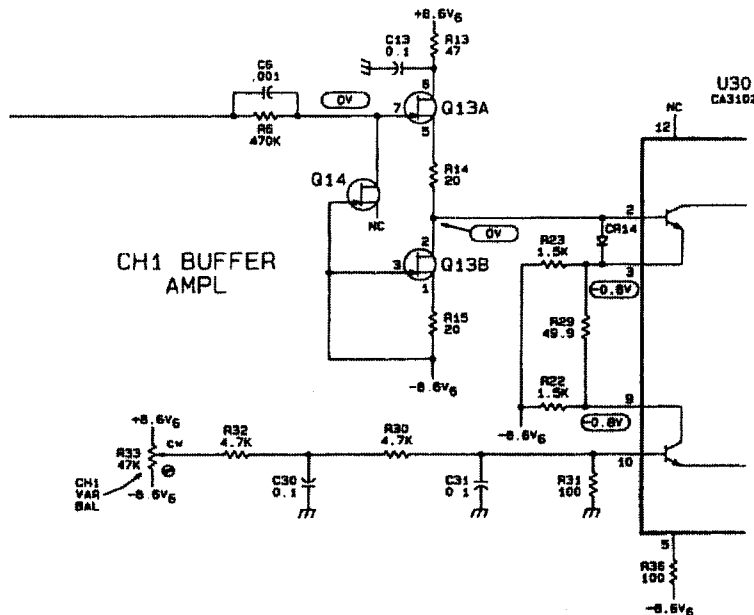

MANUAL CHANGE INFORMATION

Product: 2205 SERVICE

Date: 2-15-89

Change Reference: M67537

DESCRIPTION

Product Group 46

DIAGRAM CHANGES (cont)

DIAGRAM 1 VERTICAL ATTENUATORS (cont)

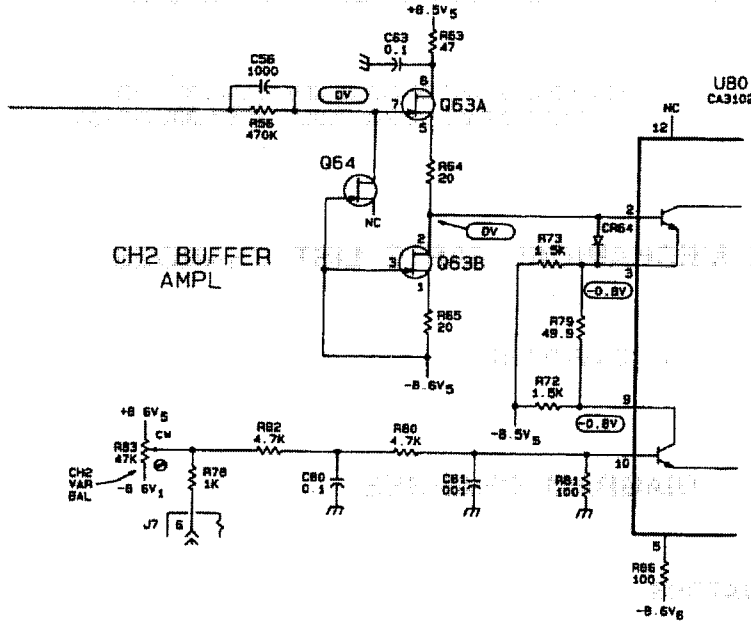

Date: 2-20-89

Change Reference: M67538

Product: 2205 SERVICE

Manual Part Number: 070-6716-00

DESCRIPTION

Product Group 46

EFFECTIVE SERIAL NUMBER: HK10500

REPLACEABLE MECHANICAL PARTS LIST CHANGES

CHANGE TO:

2-40 210-0409-00 HK10500 4 NUT,PLAIN,HEX: 8-32 X 0.312,BRS CD PL

STANDARD ACCESSORIES

Replace the power cord kits, Options A1 through A5 as follows:

<u>Replace:</u>		<u>With:</u>
020-0859-00	—————>	020-1684-00 (Option A1)
020-0860-00	—————>	020-1685-00 (Option A2)
020-0861-00	—————>	020-1686-00 (Option A3)
020-0862-00	—————>	020-1687-00 (Option A4)
020-0863-00	—————>	020-1688-00 (Option A5)

The new power cord kits contain the following accessories:

- a) Appropriate Power Cord
- b) 159-0032-00 Fuse Cartridge
- c) 343-0003-00 Loop Clamp
- d) 211-0721-00 Screw
- e) 210-0803-00 Washer

CONTAINING INFORMATION

SECRET

1. This document contains information...

2. It is intended for the use of...

3. It is to be controlled...

4. It is to be kept...

5. It is to be destroyed...

SECRET

SECRET

6. This document contains information...

SECRET

7. This document contains information...

- 8. This document contains information...
- 9. This document contains information...
- 10. This document contains information...
- 11. This document contains information...
- 12. This document contains information...

13. This document contains information...

- 14. This document contains information...
- 15. This document contains information...
- 16. This document contains information...
- 17. This document contains information...

Date: 5-2-89 Change Reference: M68110

Product: 2205 SERVICE Manual Part Number: 070-6716-00

DESCRIPTION

Product Group 46

EFFECTIVE SERIAL NUMBER: HK11184

REPLACEABLE ELECTRICAL PARTS LIST CHANGES
(CHASSIS PARTS)

CHANGE TO:

R893 311-2444-00 RES,VAR,NONWW: TRMR,2.2M OHM,30%

REPLACEABLE MECHANICAL PARTS LIST CHANGES

REMOVE:

Fig. & Index	Part Number	Qty	Name & Description
2-26	384-1710-00	1	EXTENSION SHAFT: 13MM X 7MM OD,W/STEP,4MM ID

WYOMING CHILD SUPPORT LAW



Chapter 20, Title 20, Wyoming Statutes

Section 20-2-101. Purpose and scope of chapter.

(a) The purpose of this chapter is to provide for the support of children of divorced, separated, or never-married parents.

(b) This chapter applies to all children of divorced, separated, or never-married parents.

SECTION 20-2-102. Definitions.

(a) "Child" means a child of a divorced, separated, or never-married parent who is under the age of 18 years.

SECTION 20-2-103. Child support order.

(a) The court may, upon the filing of a petition for child support, order the noncustodial parent to pay to the custodial parent a sum of money for the support of the child.

(b) The court may, upon the filing of a petition for child support, order the noncustodial parent to pay to the custodial parent a sum of money for the support of the child.

(c) The court may, upon the filing of a petition for child support, order the noncustodial parent to pay to the custodial parent a sum of money for the support of the child.

(d) The court may, upon the filing of a petition for child support, order the noncustodial parent to pay to the custodial parent a sum of money for the support of the child.

(e) The court may, upon the filing of a petition for child support, order the noncustodial parent to pay to the custodial parent a sum of money for the support of the child.

(f) The court may, upon the filing of a petition for child support, order the noncustodial parent to pay to the custodial parent a sum of money for the support of the child.

(g) The court may, upon the filing of a petition for child support, order the noncustodial parent to pay to the custodial parent a sum of money for the support of the child.

(h) The court may, upon the filing of a petition for child support, order the noncustodial parent to pay to the custodial parent a sum of money for the support of the child.

(i) The court may, upon the filing of a petition for child support, order the noncustodial parent to pay to the custodial parent a sum of money for the support of the child.

(j) The court may, upon the filing of a petition for child support, order the noncustodial parent to pay to the custodial parent a sum of money for the support of the child.

(k) The court may, upon the filing of a petition for child support, order the noncustodial parent to pay to the custodial parent a sum of money for the support of the child.

(l) The court may, upon the filing of a petition for child support, order the noncustodial parent to pay to the custodial parent a sum of money for the support of the child.

(m) The court may, upon the filing of a petition for child support, order the noncustodial parent to pay to the custodial parent a sum of money for the support of the child.

(n) The court may, upon the filing of a petition for child support, order the noncustodial parent to pay to the custodial parent a sum of money for the support of the child.

(o) The court may, upon the filing of a petition for child support, order the noncustodial parent to pay to the custodial parent a sum of money for the support of the child.

(p) The court may, upon the filing of a petition for child support, order the noncustodial parent to pay to the custodial parent a sum of money for the support of the child.

(q) The court may, upon the filing of a petition for child support, order the noncustodial parent to pay to the custodial parent a sum of money for the support of the child.

Date: 01-20-90

Change Reference: M67539

Product: 2205 SERVICE

Manual Part Number: 070-6716-00

DESCRIPTION

Product Group 46

EFFECTIVE SERIAL NUMBER: HK10500

REPLACEABLE ELECTRICAL PARTS LIST CHANGES

CHANGE TO:

U940	156-0366-00	4013DUAL FLIP-FLOP
U540	156-0388-00	74LS74N DUAL FLIP-FLOP

REPLACEABLE MECHANICAL PARTS LIST CHANGES

REMOVE:

Fig. & Index	Part Number	Qty	Name & Description
	342-0804-00	3	
	211-0305-00	6	

ADD:

211-1178-00	3	Washer, shoulder: u/w TO-220 transistor
211-0304-00	6	4-40 X .312, pan head, T9 torx

NOTE

To keep the vertical output transistors cool add a thin layer of thermal grease #249 thermalloy (006-2655-00) on the cases of vertical output transistors Q236, Q237, Q238, Q239 and on both sides of the white washer which is part of (214-4039-00) that is shown as item 54 in exploded view Fig.2 of the service manual.

EFFECTIVE SERIAL NUMBER: HK10700

A3 FRONT PANEL CIRCUIT BOARD ASSEMBLY

CHANGE TO:

C378	281-0767-00	CAPACITOR, 330 pF, 20%, 100V.
------	-------------	-------------------------------

Date: 01-20-90Change Reference: M67539Product: 2205 SERVICEManual Part Number: 070-6716-00**DESCRIPTION**

Product Group 46

DIAGRAM CHANGES**DIAGRAM  FRONT PANEL CONTROLS**

Change the value of capacitor C378 (location 8H) to 330 pF.

EFFECTIVE SERIAL NUMBER: HK11110**REPLACEABLE ELECTRICAL PARTS LIST CHANGES****DELETE:**

L712	120-1631-00
L713	120-1631-00
L93	120-1631-00
L96	120-1631-00
E90	276-0752-00
E91	276-0752-00
E92	276-0752-00
E93	276-0752-00

CHANGE TO:

L93	R97	307-0106-00 RESISTOR, FIXED; 4.7 Ω , 5% 1/4W.
L96	R96	307-0106-00 RESISTOR, FIXED; 4.7 Ω , 5% 1/4W.
E90	R92	307-0106-00 RESISTOR, FIXED; 4.7 Ω , 5% 1/4W.
E91	R93	307-0106-00 RESISTOR, FIXED; 4.7 Ω , 5% 1/4W.
E92	R94	307-0106-00 RESISTOR, FIXED; 4.7 Ω , 5% 1/4W.
E93	R95	307-0106-00 RESISTOR, FIXED; 4.7 Ω , 5% 1/4W.
L712	W712	131-0566-03 DUMMY RESISTOR.
L713	W713	131-0566-03 DUMMY RESISTOR.

FIG. 9-7 A2 TIMEBASE/ATTENUATOR BOARD.**CHANGE TO:**

L712	W712 grid location (1C).
L713	W713 grid location (1C).
L93	R97 grid location (1B).
L96	R96 grid location (1C).
E90	R92 grid location (1A).
E91	R93 grid location (1B).
E92	R94 grid location (1A).
E93	R95 grid location (1B).

DESCRIPTION

Product Group 46

DIAGRAM CHANGES

DIAGRAM 1 VERTICAL ATTENUATORS

- Change the value and circuit number of L93 (location 7B) to R97 4.7 Ω .
- Change the value and circuit number of L96 (location 7B) to R96 4.7 Ω .
- Change the value and circuit number of E90 (location 8B) to R92 4.7 Ω .
- Change the value and circuit number of E91 (location 7B) to R93 4.7 Ω .
- Change the value and circuit number of E92 (location 8B) to R94 4.7 Ω .
- Change the value and circuit number of E93 (location 7B) to R95 4.7 Ω .

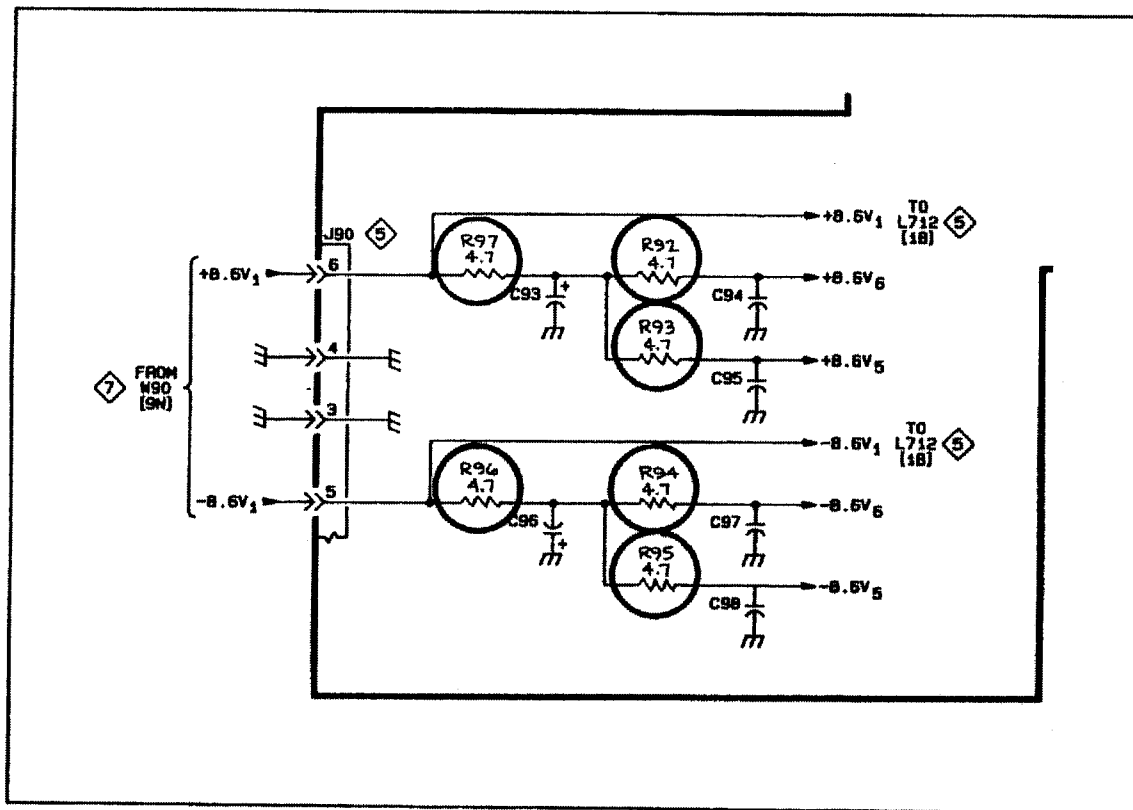

CONFIDENTIAL - SECURITY INFORMATION

REPORT NO. 100-100000-100000

DATE: 10/10/10

BY: [Redacted]

TO: [Redacted]

FROM: [Redacted]

SUBJECT: [Redacted]

REPORT NO. 100-100000-100000

CONFIDENTIAL - SECURITY INFORMATION

The following information was obtained from a review of the files of the [Redacted] and is being furnished to you for your information. It is to be used only for the purpose for which it was obtained and is not to be disseminated outside the [Redacted] without the express written consent of the [Redacted].

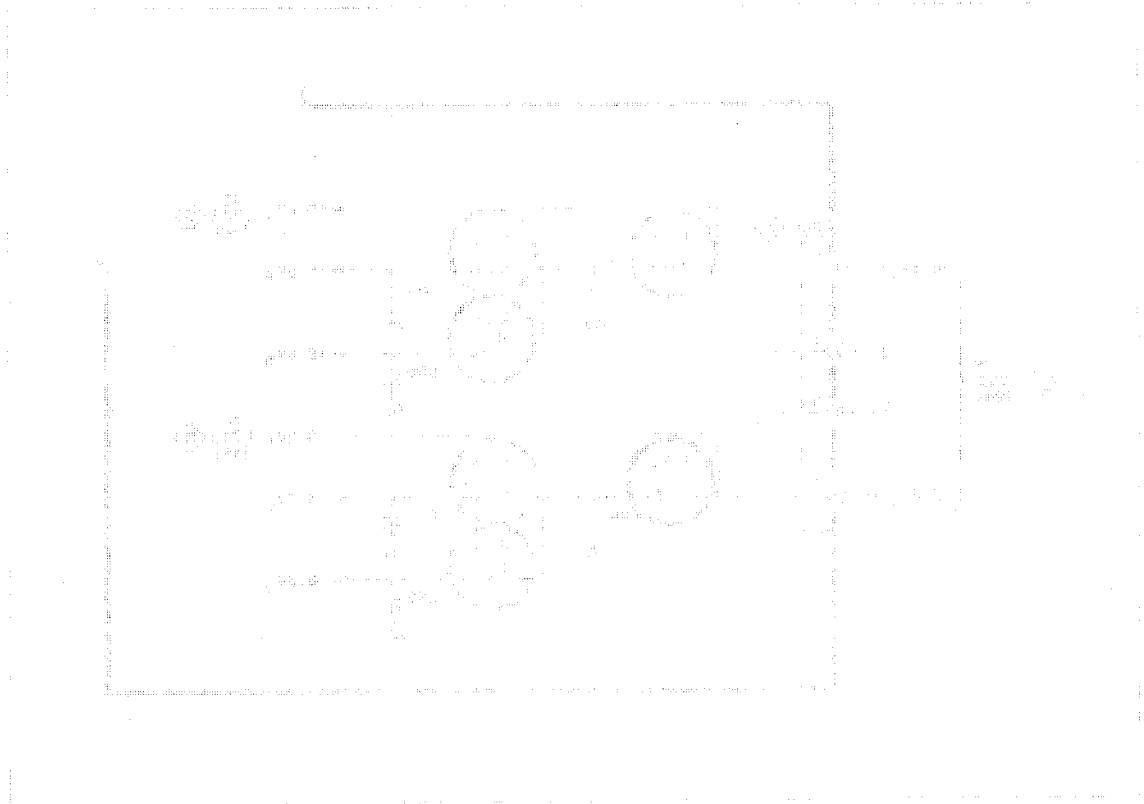

DESCRIPTION

Product Group 46

SEE BELOW FOR EFFECTIVE SERIAL NUMBERS

**Section 7
OPTIONS AND ACCESSORIES**

Page 7-1.

Option 23

Two P6119 1X-10X
Selectable-attenuation
Probes

Page 7-2.

Option 23

Two P6119 1X-10X Selectable-attenuation Probes are provided
in place of the standard P6103 10X Probes.

Page 7-3.

**Table 7-2
Optional Accessories**

Description	Part Number
Attenuator Voltage Probes	
10X Standard	P6103
10X Subminiature	P6130
10X Environmental	P6008
1X-10X Selectable	P6119
100X High Voltage	P6009
1000X High Voltage	P6015

MEMORANDUM FOR THE RECORD



DATE: 10/15/54

TO: SAC, NEW YORK (100-100000)

FROM: SA [Name], NEW YORK

RE: [Subject Name]

Reference is made to

NY File # [Number]

NY File # [Number]

NY File # [Number]

NY File # [Number]

NY File # [Number]

It is noted that [Subject Name] was born [Date] at [Location].

NY File # [Number]

Very truly yours,
[Signature]

Special Agent in Charge

Special Agent in Charge

Enclosure

100-100000-1000

100-100000-1000

Product: 2205 OSCILLOSCOPE SERVICE

Date: 3-20-90

Change Reference: C2/0390

Manual Part Number: 070-6716-00

DESCRIPTION

Product Group 46

EFFECTIVE SERIAL NUMBER: ALL

TEXT CHANGES

PAGE 1-4

CHANGE TO:

Table 1-1 (cont)

Characteristics	Performance Requirements	
Sweep Linearity	Magnified	
	X1	X10
	$\pm 7\%^1$	$\pm 10\%^2$

¹ Linearity measured over any 2 of the center 8 divisions.
² Linearity measured over any 2 of the center 8 divisions, excluding the first 40 ns.

PAGE 4-6

CHANGE:

Step 1, parts d and h.

- d. CHECK – Timing accuracy is within 3% (0.24 division at the tenth vertical graticule line) and linearity is within 7% (0.14 division over any 2 of the center 8 divisions).
- h. Use the Horizontal POSITION controls to align the first time marker that is 40 ns beyond the start of the sweep with the second vertical graticule line.

PAGE 4-7

CHANGE:

Step 1, part i.

- i. CHECK – Timing accuracy is within 4% (0.32 division at the tenth vertical graticule line) and linearity is within 10% (0.2 division over any 2 of the center 8 divisions). Exclude any portion of the sweep past the 50th magnified division.

PAGE 5-14

CHANGE:

Step 8, parts e, i, and j.

- e. CHECK – Timing accuracy is within 3% (0.24 division at the tenth vertical graticule line) and linearity is within 7% (0.14 division over any 2 of the center 8 divisions).
- i. Use the Horizontal POSITION controls to align the first time marker that is 40 ns beyond the start of the sweep with the second vertical graticule line.
- j. CHECK – Timing accuracy is within 4% (0.32 division at the tenth vertical graticule line) and linearity is within 10% (0.2 division over any 2 of the center 8 divisions). Exclude any portion of the sweep past the 50th magnified division.

NOTARION PUBLICO JAVIER



NOTARION PUBLICO JAVIER

NOTARION PUBLICO JAVIER

NOTARION PUBLICO JAVIER

NOTARION PUBLICO JAVIER

NOTARION PUBLICO JAVIER

NOTARION PUBLICO JAVIER

NOTARION PUBLICO JAVIER

NOTARION PUBLICO JAVIER

NOTARION PUBLICO JAVIER

NOTARION PUBLICO JAVIER

NOTARION PUBLICO JAVIER

NOTARION PUBLICO JAVIER

NOTARION PUBLICO JAVIER

NOTARION PUBLICO JAVIER

NOTARION PUBLICO JAVIER

NOTARION PUBLICO JAVIER

NOTARION PUBLICO JAVIER

NOTARION PUBLICO JAVIER

NOTARION PUBLICO JAVIER

NOTARION PUBLICO JAVIER

NOTARION PUBLICO JAVIER

NOTARION PUBLICO JAVIER

NOTARION PUBLICO JAVIER

NOTARION PUBLICO JAVIER

NOTARION PUBLICO JAVIER

NOTARION PUBLICO JAVIER

NOTARION PUBLICO JAVIER

NOTARION PUBLICO JAVIER

NOTARION PUBLICO JAVIER

NOTARION PUBLICO JAVIER

NOTARION PUBLICO JAVIER

NOTARION PUBLICO JAVIER

NOTARION PUBLICO JAVIER

Date: 8-23-91 Change Reference: M73789(Rev)

Product: 2205 SERVICE MANUAL Manual Part Number: 070-6716-00

DESCRIPTION

Product Group 46

EFFECTIVE SERIAL NUMBER: HK54509 and HK12226

TEXT CHANGES

Page 4-2 Table 4-1 **TEST EQUIPMENT REQUIRED**

13. Auto Transformer	Load: 95 Vac to 128 Vac, 40W (60 VA).	Adjust switching frequency of power supply	Tecnipower® W10MT3W
----------------------	---------------------------------------	--	---------------------

PAGE 5-4

ADD:

Check/Adjust Switching Frequency (R998)

(The following steps must be performed at the beginning of the power supply adjustment procedure.)

- a. ADJUST—R998 (SW FREQ ADJ) fully counterclockwise. Set the LINE VOLTAGE SELECTOR switch to 115V.
- b. Connect the power cord from the auto transformer to the instrument. Turn the instrument power on.
- c. Increase auto transformer voltage to 128V. Allow at least 10 minutes warm up time before proceeding with the following adjustments and checks.
- d. Set up test oscilloscope:
VERTICAL MODE to CH1
CH1 to 1V/DIV (X10 probe) or 10V/DIV (X1 probe), DC Coupled
HORIZONTAL MODE to X1, 5µs/DIV
TRIGGER MODE to P-P AUTO, CH1 SOURCE
- e. Monitor the waveform at W951 via X1 or X10 probe. The period of the waveform will be approximately 3 divisions or 15µs.
- f. ADJUST—R998 (SW FREQ ADJ) until the period of the waveform is 4.8 divisions or 24µs.
- g. CHECK—Period of the waveform is within 20 to 25µs (4.0 to 5.0 divisions) while the auto transformer voltage is adjusted through the range of 95 to 128V.
- h. Readjust R998, if necessary, to keep the period of the waveform within specification through the rated line voltage range.

REPLACEABLE ELECTRICAL PARTS LIST CHANGES

REMOVE:

A1C932 290-0806-00 CAP,FXD,ELCTLT:3.3UF,+75-10%,350VDC

ADD:

A6 671-2115-00 CIRCUIT BD ASSY:FREQUENCY STABILIZING CIRCUIT

A6C932 290-0806-00 CAP,FXD,ELCTLT:3.3UF,+75-10%,350VDC

A6C993 290-1150-00 CAP,FXD,ELCTLT:15UF,+50-10%,16VDC

A6R996 315-0362-00 RES,FXD,FILM:3.6K OHM,5%,0.25W

A6R997 315-0362-00 RES,FXD,FILM:3.6K OHM,5%,0.25W

A6R998 311-2421-01 RES,VAR,NONWW:TRMR,1K

A6CR992 152-0141-02 DIODE,SIG:ULTRA FAST;40V,150MA,4NS,2PF,1N4152

A6VR989 152-0217-00 DIODE,ZENER:8.2V,5%,0.4W;1N756A FMLY

MANUAL CHANGE INFORMATION

Product: 2205 SERVICE

Date: 8-23-91

Change Reference: M73789(Rev)

DESCRIPTION

Product Group 46

DIAGRAM CHANGES

DIAGRAM 7 POWER SUPPLY

Remove C932 (location 5E) and add A6 Frequency Stabilizing Circuit Board to power supply:

Connect J901-1 to + hole where C932 was previously installed.

Connect J901-2 to - hole (ground) where C932 was previously installed on A1.

Connect W301 to U930 pin 5 (location 7F).

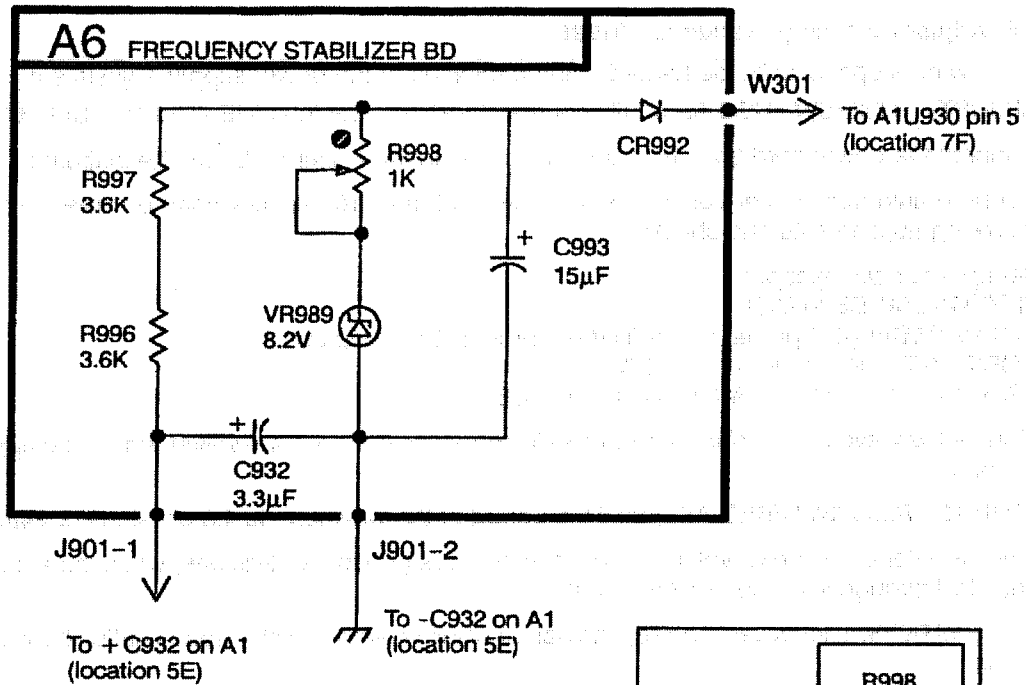

To + C932 on A1
(location 5E)

To -C932 on A1
(location 5E)

A6 Circuit Board Layout

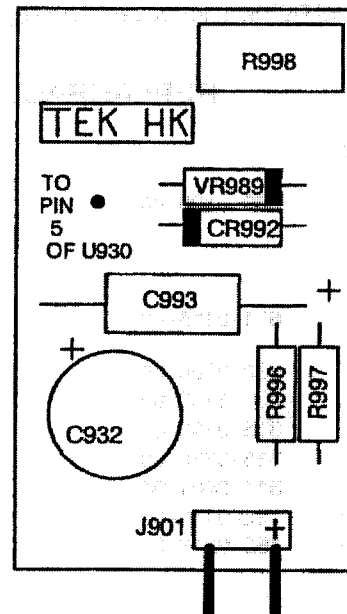

Date: 2-5-92

Change Reference: C3/0292

Product: 2205 SERVICE MANUAL

Manual Part Number: 070-6716-00

DESCRIPTION

Product Group 46

SEE BELOW FOR EFFECTIVE SERIAL NUMBERS

REPLACEABLE ELECTRICAL PARTS LIST CHANGES

CHANGE TO:

Comp.	Tektronix Part No.	Effective Serial Number	Description	Change Ref.
A1C584	285-1341-00	HK53916	CAP,FXD,PLASTIC,METALIZED FILM: 0.1 UF,20%,100V	M70965
A1R145	311-2363-00	HK58461	RES, VAR, NONWW: TRMR, 1K OHM, 0.5 W (NOMINAL)	M74371
A1R145	311-2364-00	HK58461	RES, VAR, NONWW: TRMR, 4.7K OHM, 0.5 W (TEST SELECTABLE)	M74371
A1R195	311-2363-00	HK58461	RES, VAR, NONWW: TRMR, 1K OHM, 0.5 W (NOMINAL)	M74371
A1R195	311-2364-00	HK58461	RES, VAR, NONWW: TRMR, 4.7K OHM, 0.5 W (TEST SELECTABLE)	M74371
A1R238	315-0513-00	HK51241	RES,FXD,FILM: 51K OHM,5%,0.25W	M69394
A1R245	315-0132-00	HK51241	RES,FXD,FILM: 1.3K OHM,5%,0.25W	M69394
A1R249	315-0513-00	HK51241	RES,FXD,FILM: 51K OHM,5%,0.25W	M69394
A1R250	315-0132-00	HK51241	RES,FXD,FILM: 1.3K OHM,5%,0.25W	M69394
A1R368	315-0112-00	HK51712	RES,FXD,FILM: 1.1K OHM,5%,0.25W	M70018
A1R432	315-0104-00	HK54142	RES,FXD,FILM: 100K OHM,5%,0.25W	M70967
A1R445	311-2470-00	HK52626	RES, VAR, NONWW: TRMR, 470K OHM, 0.5 W	M70276
A1R446	311-2470-00	HK52626	RES, VAR, NONWW: TRMR, 470K OHM, 0.5 W	M70276
A2R740	321-0270-00	HK51241	RES,FXD,FILM: 6.34K OHM,1%,0.125W	M70017

REPLACEABLE MECHANICAL PARTS LIST CHANGES

Fig. & Index No.

Tektronix Part No.

Serial Number Effective

Dscont.

Qty.

Description

CHANGE TO:

1-27	211-0730-00	HK51711	4	SCR,ASSEM WSHR: 6-32 X 0.375,PNH,STL	M70276
	211-0730-00	HK51712	2	SCR,ASSEM WSHR: 6-32 X 0.375,PNH,STL	M70276
1-27.1	213-0882-00	HK51712	2	SCR,TPG,TR: 6-32 X 0.437 TAPTITE,PNH,STL	M70276

Note: See the partial illustration on the following page illustrating the locations of the screws for Index No. 1-27 and 1-27.1.

2-40	220-0555-00	HK53430	4	NUT,PLAIN,HEX: 8-32 X 0.25 HEX,STL CD PL	M70966
	210-0458-00	HK53431	4	NUT,PL,ASSEM,WA: 8-32 X 0.344,STL CD PL	M70966
	210-0007-00	HK53430	4	WASHER,LOCK: #8 EXT,0.02 THK,STL	M70966

ADD:

2-39.1	210-0804-00	HK50001	4	WASHER,FLAT: 0.17 ID X 0.375 OD X 0.032 STL CD	M76496
--------	-------------	---------	---	--	--------

Note: These four washers are used in conjunction with the four screws (Index No. 2-39) that secure the transformer to the rear chassis of the instrument.

MANUAL CHANGE INFORMATION

Product: 2205 SERVICE MANUAL

Date: 2-5-92

Change Reference: C3/0292

DESCRIPTION

Product Group **46**

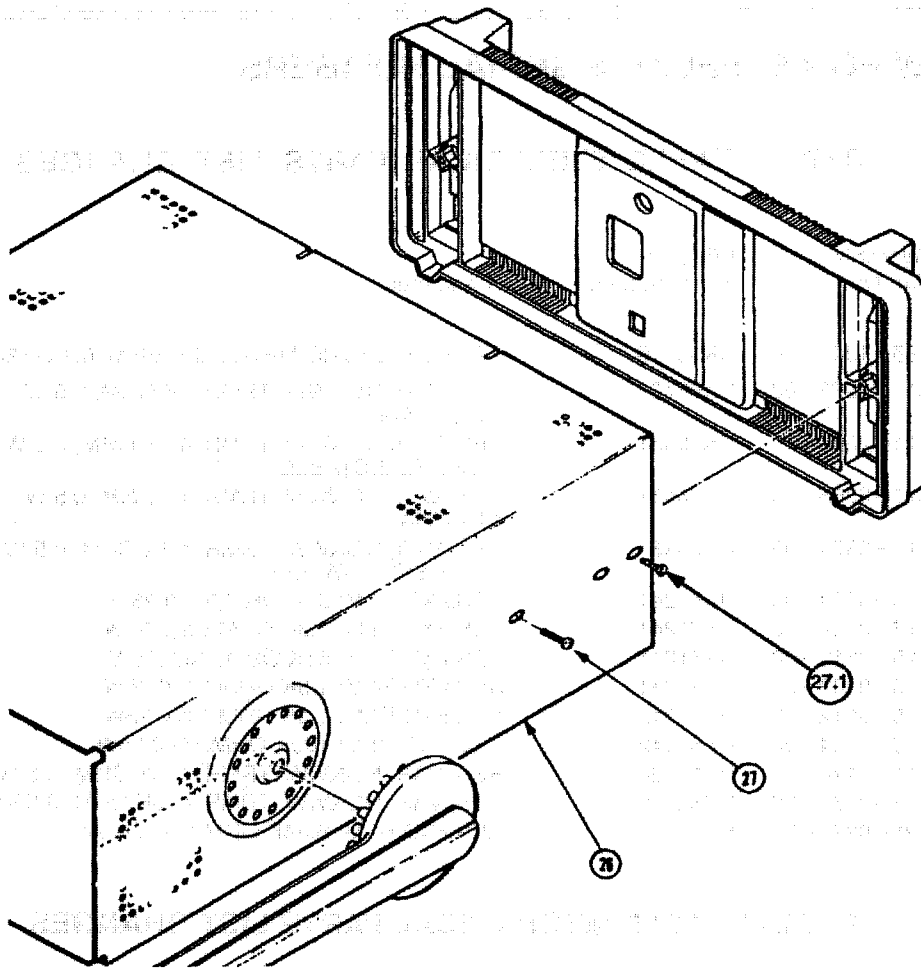

Partial Figure 2 Exploded View

MANUAL CHANGE INFORMATION

Product: 2205 SERVICE MANUAL

Date: 2-5-92

Change Reference: C3/0292

DESCRIPTION

Product Group 46

DIAGRAM CHANGES

DIAGRAM			Effective Serial Number	Ref. Number
2	VERTICAL PREAMP & OUTPUT AMPLIFIER			
	Change the value of resistor R245 (location 3P) to 1.3 kΩ.		HK51241	M69394
	Change the value of resistor R238 (location 3P) to 51 kΩ..		HK51241	M69394
	Change the value of resistor R249 (location 8P) to 51 kΩ..		HK51241	M69394
	Change the value of resistor R250 (location 8P) to 1.3 kΩ..		HK51241	M69394
	Change the nominal value of variable resistor R145 (location 2J) to 1 kΩ.		HK58461	M74371
	Change the nominal value of variable resistor R195 (location 10J) to 1 kΩ.		HK58461	M74371
3	TRIGGER			
	Change the value of resistor R368 (location 4C) to 1.1 kΩ.		HK51712	M70018
	Change the value of variable resistor R445 (location 7C) to 470 kΩ.		HK52626	M70276
	Change the value of variable resistor R446 (location 8C) to 470 kΩ.		HK52626	M70276
	Change the value of resistor R432 (location 9D) to 100 kΩ.		HK54142	M70967
5	SWEEP GENERATOR & HORIZONTAL AMPLIFIER			
	Change the value of resistor R740 (location 4E) to 6.34 kΩ.		HK51241	M70017

STATE OF TEXAS

County of _____

Know all men by these presents

that _____

do hereby certify that

Date: 7-23-92 Change Reference: M77514

Product: 2205 SERVICE MANUAL Manual Part Number: 070-6716-00

DESCRIPTION

Product Group 46

EFFECTIVE SERIAL NUMBER: HK10001

REPLACEABLE ELECTRICAL PARTS LIST CHANGES

CHANGE TO:

F901

159-0301-00

FUSE, CARTRIDGE: 0.75A, 250V, SLOW BLOW

WORLDWIDE TELECOMMUNICATIONS

INTERNATIONAL TELEPHONE

TELEPHONE SERVICE

TELEPHONE SERVICE

TELEPHONE SERVICE

TELEPHONE SERVICE

TELEPHONE SERVICE

TELEPHONE SERVICE

Date: 7-23-92 Change Reference: M74107

Product: 2205 SERVICE MANUAL Manual Part Number: 070-6716-00

DESCRIPTION

Product Group 46

EFFECTIVE SERIAL NUMBER: HK61981

REPLACEABLE ELECTRICAL PARTS LIST CHANGES

CHANGE TO:

A4S901 260-1849-00 SWITCH, PUSH: DPDT, 4A, 250VAC

REPLACEABLE MECHANICAL PARTS LIST CHANGES

Fig &
Index
No.

Part No.

Qty

NAME & DESCRIPTION

REMOVE:

2- 200-2735-00 1 COVER, POWER SW: BLACK,POLYCARBONATE

MEMORANDUM FOR THE DIRECTOR

CONFIDENTIAL

DATE: 10/15/54

TO: DIRECTOR

FROM: SAC, NEW YORK

SUBJECT: [REDACTED]

RE: [REDACTED]

[REDACTED]

[REDACTED]

[REDACTED]

[REDACTED]

[REDACTED]

[REDACTED]

[REDACTED]

[REDACTED]

[REDACTED]

[REDACTED]

[REDACTED]

[REDACTED]

Date: 2-10-93 Change Reference: M75549 (Rev)

Product: 2205 SERVICE MANUAL Manual Part Number: 070-6716-00

DESCRIPTION

Product Group 46

**EFFECTIVE SERIAL NUMBERS: HK58740 – HK61954
HK61981 – HK62321
HK62331 & Above**

REPLACEABLE ELECTRICAL PARTS LIST CHANGES

CHANGE TO:

Comp.	Tektronix Part No.	Description
A2	671-0390-01	CIRCUIT BOARD ASSY: TIMEBASE/ATTEN (INCLUDES A2R721)
A2S701	260-2408-01	

REPLACEABLE MECHANICAL PARTS LIST CHANGES

Fig. & Index No.	Tektronix Part No.	Qty.	Description
------------------	--------------------	------	-------------

REMOVE:

2-16	376-0224-01	1	CPLG, SHAFT, RGDR: W/213-0153-00
2-17	384-1714-00	1	EXTENSION SHAFT: 133MM L X 2MM OD, SST

MANUAL CHANGE INFORMATION

Product: 2205 SERVICE MANUAL

Date: 2-10-93

Change Reference: M75549 (Rev)

DESCRIPTION

Product Group 46

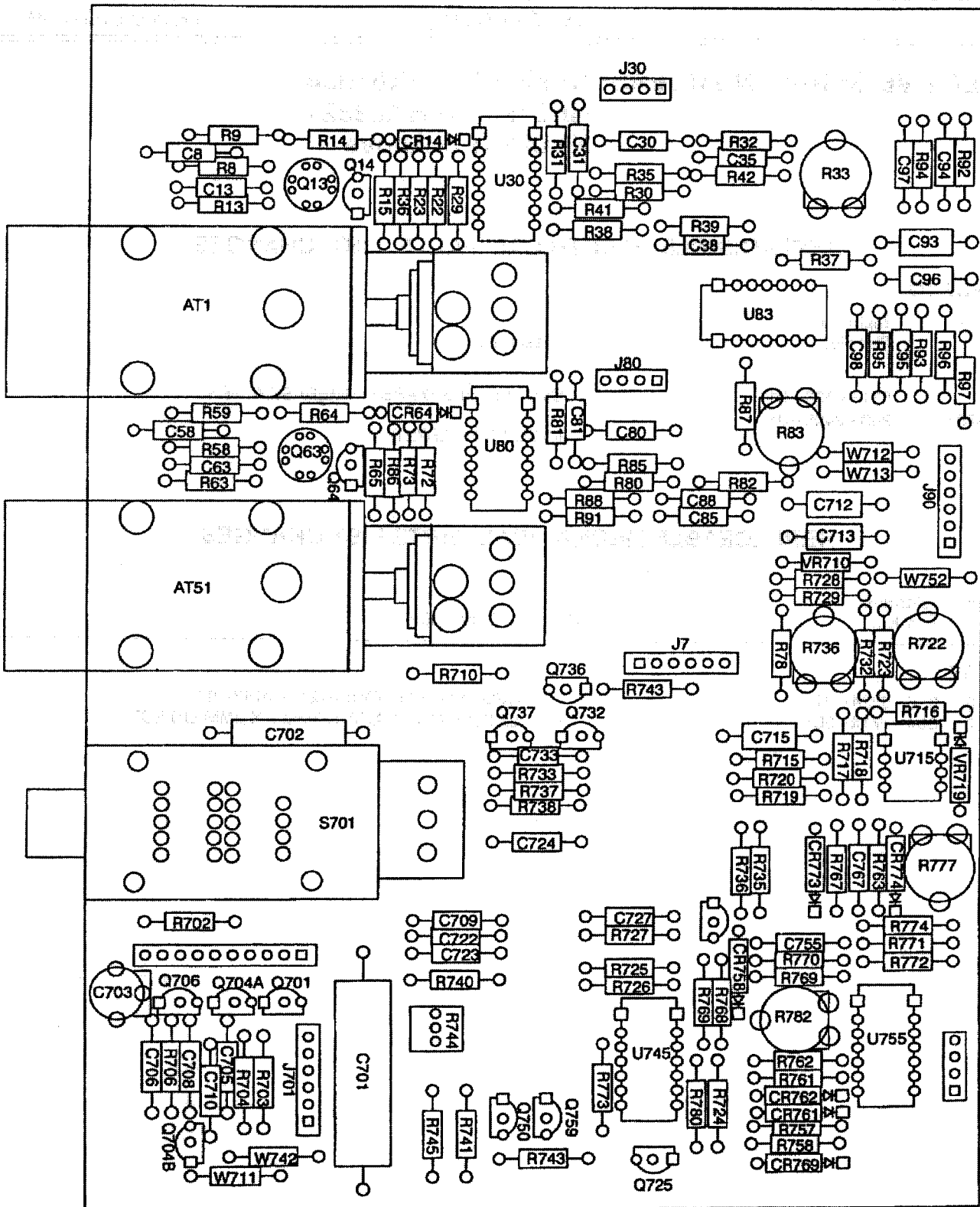

A2—Timebase/Attenuator board (SN HK58741 and above).

MANUAL CHANGE INFORMATION

Product: 2205 SERVICE MANUAL

Date: 2-10-93

Change Reference: M75549 (Rev)

DESCRIPTION

Product Group 46

DIAGRAM CHANGES

DIAGRAM 5 **SWEEP GENERATOR & HORIZONTAL AMPLIFIER**

The new S701 has several modifications which require circuit wiring modifications. These changes are illustrated with the partial schematic below.

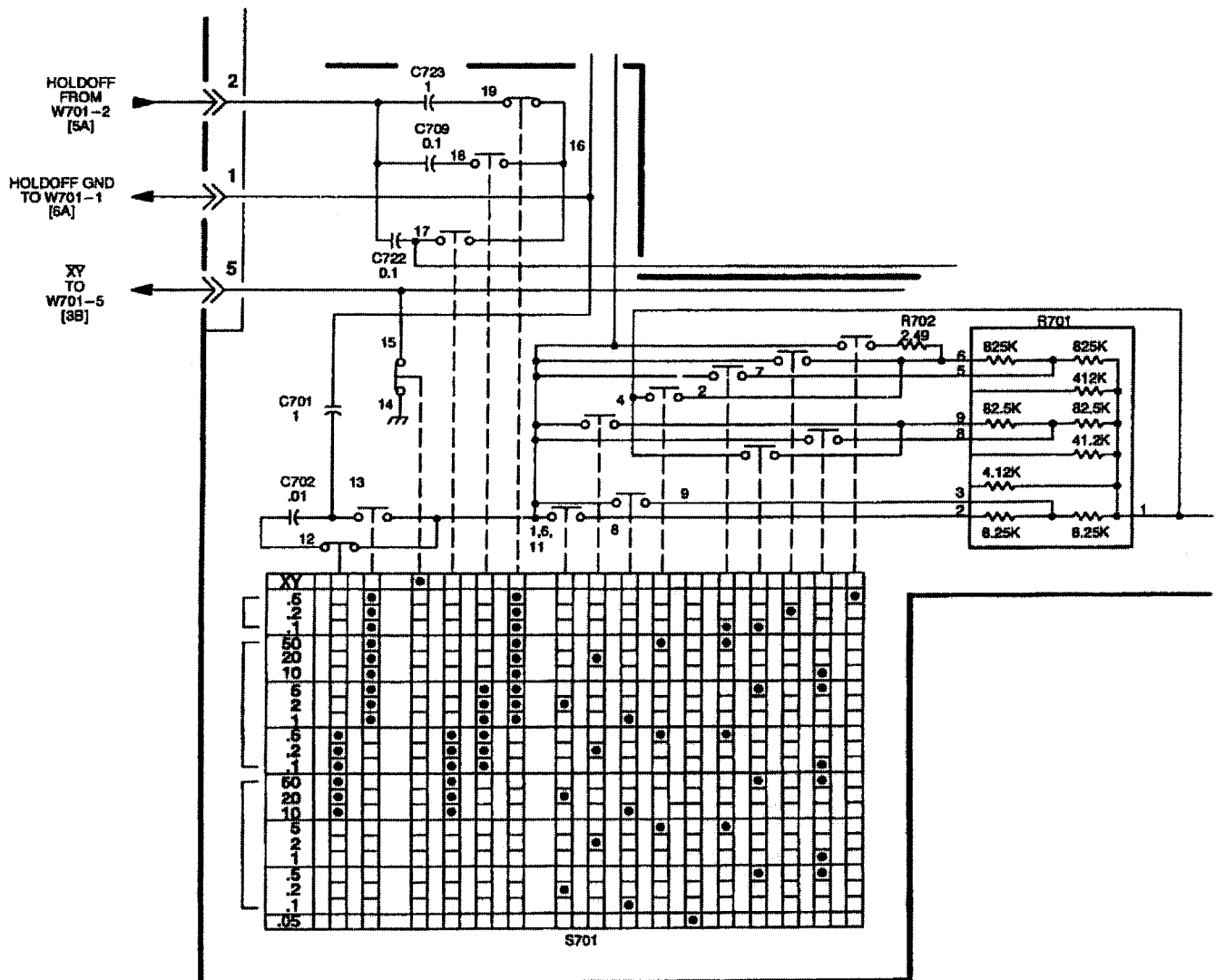

STATE OF TEXAS

COUNTY OF DALLAS

IN SENATE

NOVEMBER 1900

REPORT OF THE

COMMISSIONERS OF THE GENERAL LAND OFFICE



FOR THE YEAR ENDING SEPTEMBER 30, 1900



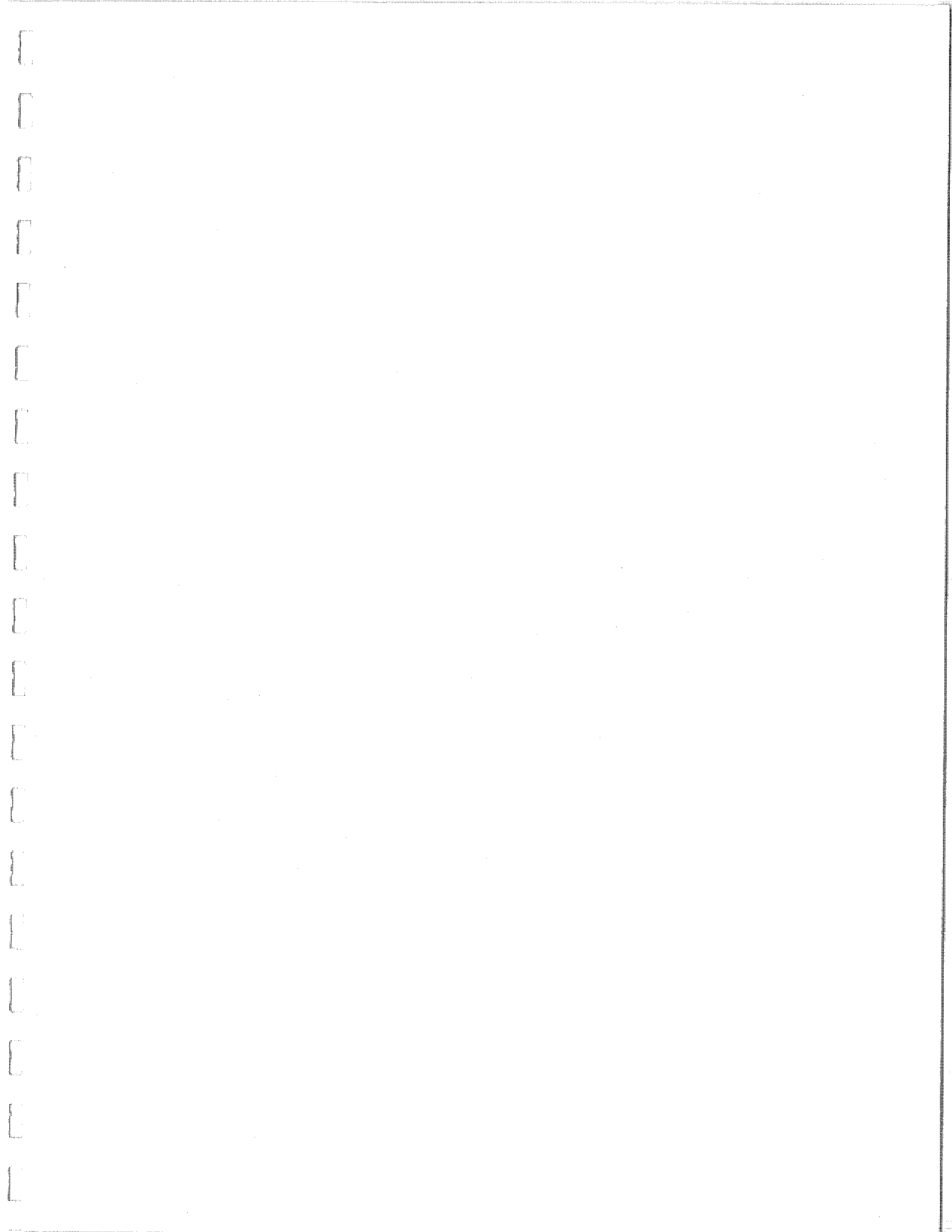



SECRET

SECRET



Printed on recyclable paper. Please recycle



DIAGRAMS AND CIRCUIT BOARD ILLUSTRATIONS

Symbols

Graphic symbols and class designation letters are based on ANSI Standard Y32.2-1975.

Logic symbology is based on ANSI/IEEE 91-1984. Logic symbols depict the logic function performed and may differ from the manufacturer's data.

The overline on a signal name indicates that the signal performs its intended function when it is in the LO state.

Abbreviations are based on ANSI Y1.1-1972.

Other ANSI standards that are used in the preparation of diagrams by Tektronix, Inc., are:

Y14.15-1966 Drafting Practices.
Y14.2M-1979 Line Conventions and Lettering.
ANSI/IEEE 280-1985 Letter Symbols for Quantities Used in Electrical Science and Electrical Engineering.

American National Standards Institute
1430 Broadway
New York, New York 10018

Component Values

Electrical components shown on the diagrams are in the following units unless noted otherwise:

Capacitors Values one or greater are in picofarads (pF).
Values less than one are in microfarads (μF).
Resistors Ohms (Ω).

The information and special symbols below may appear in this manual.

Assembly Numbers and Grid Coordinates

Each assembly in the instrument is assigned an assembly number (e.g., A20). The assembly number appears on the circuit board outline on the diagram, in the title for the circuit board component location illustration, and in the lookup table for the schematic diagram and corresponding component locator illustration. The Replaceable Electrical Parts list is arranged by assemblies in numerical sequence; the components are listed by component number *(see following illustration for constructing a component number).

The schematic diagram and circuit board component location illustration have grids. A lookup table with the grid coordinates is provided for ease of locating the component. Only the components illustrated on the facing diagram are listed in the lookup table. When more than one schematic diagram is used to illustrate the circuitry on a circuit board, the circuit board illustration may only appear opposite the first diagram on which it was illustrated; the lookup table will list the diagram number of other diagrams that the circuitry of the circuit board appears on.

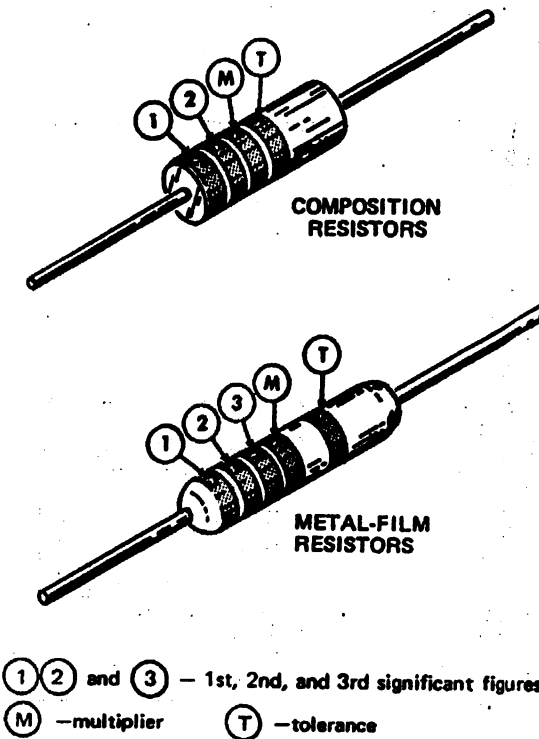
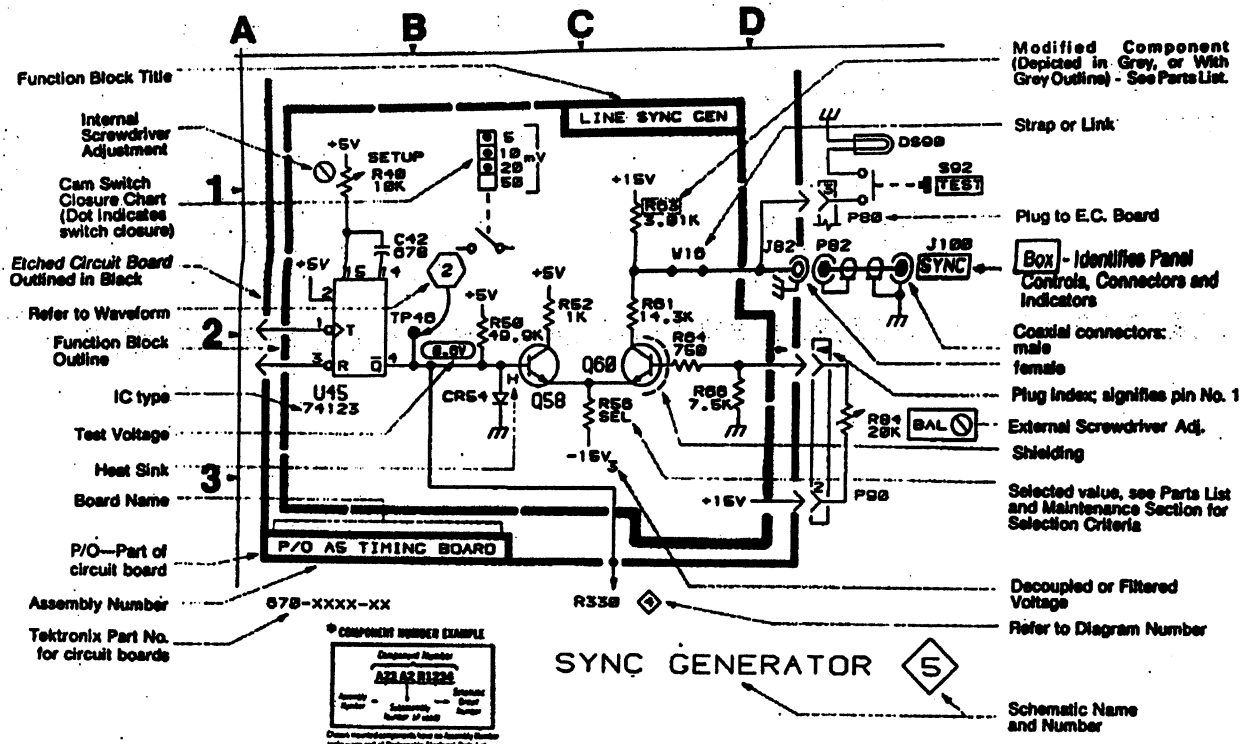

COLOR	SIGNIFICANT FIGURES	RESISTORS	
		MULTIPLIER	TOLERANCE
BLACK	0	1	---
BROWN	1	10	±1%
RED	2	10 ² or 100	±2%
ORANGE	3	10 ³ or 1 K	±3%
YELLOW	4	10 ⁴ or 10 K	±4%
GREEN	5	10 ⁵ or 100 K	±5%
BLUE	6	10 ⁶ or 1 M	±6%
VIOLET	7	---	±1/10%
GRAY	8	---	---
WHITE	9	---	---
GOLD	-	10 ⁻¹ or 0.1	±5%
SILVER	-	10 ⁻² or 0.01	±10%
NONE	-	---	±20%

(1861-204)0061-95

Figure 9-1. Color codes for resistors.

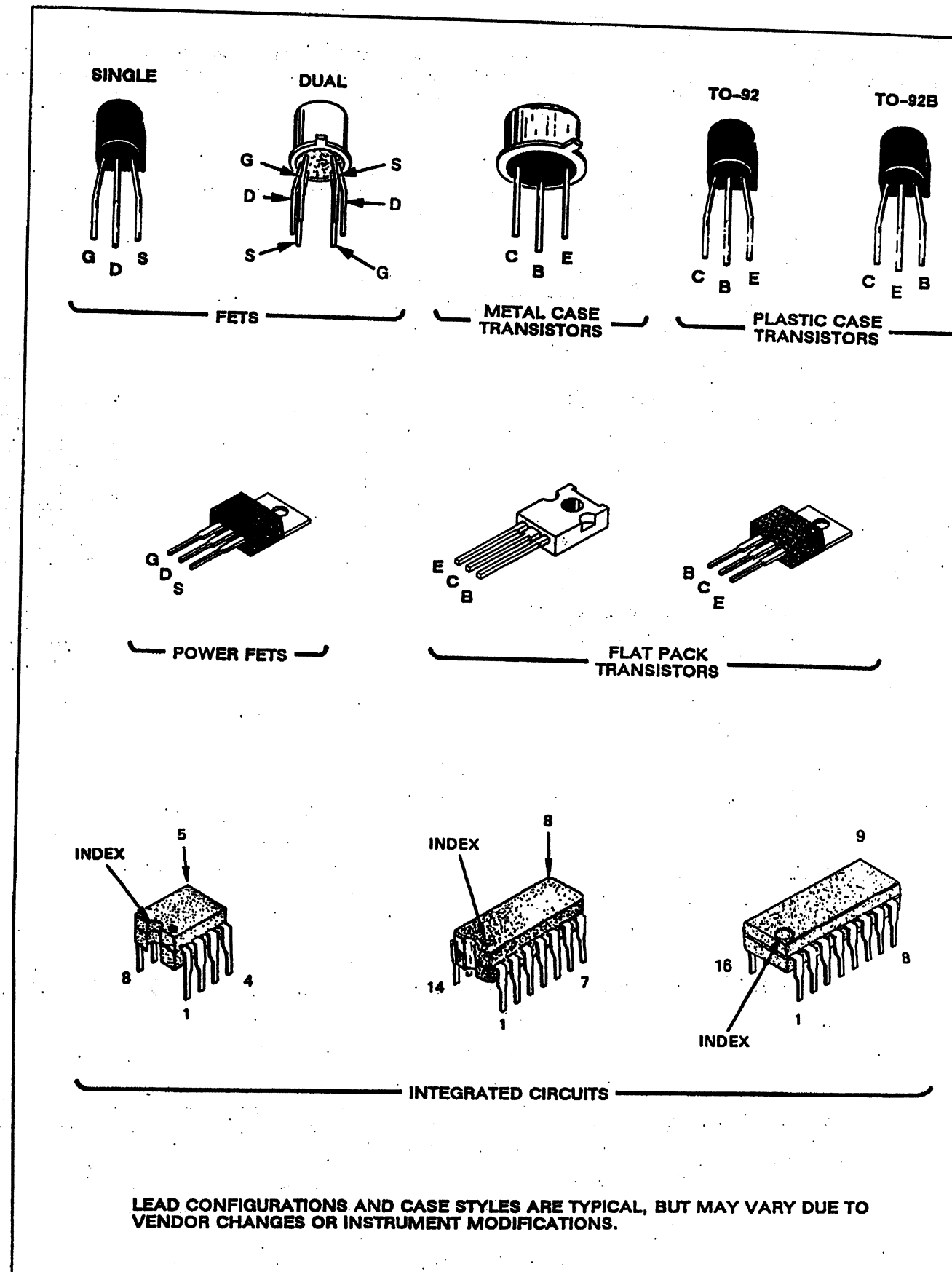

Figure 9-2. Semiconductor lead configurations.

Identify any component mounted on circuit board and to locate that component in the schematic diagram.

1. Locate the Circuit Board Illustration.
 - a. Identify the Assembly Number of the circuit board that the component is on by using the Circuit Board location illustration in this section or the mechanical parts exploded views at the rear of this manual.
 - b. In the manual, locate the tabbed foldout page that corresponds with the Assembly Number of the circuit board. The circuit board assembly numbers and names are printed on the back side of the tabs (facing the rear of the manual).

2. Determine the Circuit Number and Schematic Diagram.
 - a. Compare the circuit board with its illustration. Locate the component you are looking for by area and shape on the illustration to determine its Circuit Number.
 - b. Scan the lookup table next to the Circuit Board illustration to find the Circuit Number of the component.
 - c. Read the SCHEM NUMBER column next to the component's circuit number to find the Schematic Diagram number.

3. Locate the Component on the Schematic Diagram.
 - a. Locate the tabbed page that corresponds to the Schematic Diagram number. Schematic diagram numbers and names are printed on the front side of the tabs (facing the front of the manual).
 - b. Locate the Assembly Number in the Component Location lookup table next to the schematic diagram. Scan the CIRCUIT NUMBER column of that table to find the Circuit Number of the component you are looking for in the schematic.
 - c. In the SCHEM LOCATION column next to the component, read the grid coordinates of the component in the schematic.
 - d. Using the grid coordinates given, find the component in the schematic diagram.

PULL-OUT PAGE TABS FOR CIRCUIT BOARD ILLUSTRATION

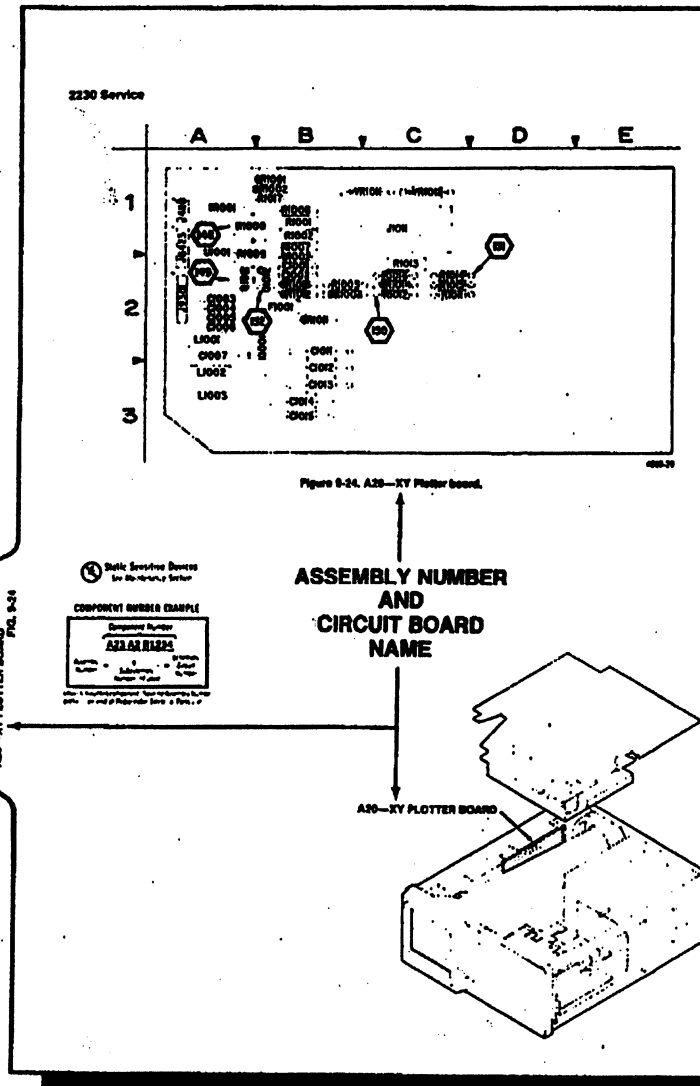

A20-XY PLOTTER BOARD

CIRCUIT NUMBER	SCHEM NUMBER	CIRCUIT NUMBER	SCHEM NUMBER	CIRCUIT NUMBER	SCHEM NUMBER
C2001	22	C2002	22	C2003	22
C2004	22	C2005	22	C2006	22
C2007	22	C2008	22	C2009	22
C2010	22	C2011	22	C2012	22
C2013	22	C2014	22	C2015	22
C2016	22	C2017	22	C2018	22
C2019	22	C2020	22	C2021	22
C2022	22	C2023	22	C2024	22
C2025	22	C2026	22	C2027	22
C2028	22	C2029	22	C2030	22
C2031	22	C2032	22	C2033	22
C2034	22	C2035	22	C2036	22
C2037	22	C2038	22	C2039	22
C2040	22	C2041	22	C2042	22
C2043	22	C2044	22	C2045	22
C2046	22	C2047	22	C2048	22
C2049	22	C2050	22	C2051	22
C2052	22	C2053	22	C2054	22
C2055	22	C2056	22	C2057	22
C2058	22	C2059	22	C2060	22
C2061	22	C2062	22	C2063	22
C2064	22	C2065	22	C2066	22
C2067	22	C2068	22	C2069	22
C2070	22	C2071	22	C2072	22
C2073	22	C2074	22	C2075	22
C2076	22	C2077	22	C2078	22
C2079	22	C2080	22	C2081	22
C2082	22	C2083	22	C2084	22
C2085	22	C2086	22	C2087	22
C2088	22	C2089	22	C2090	22
C2091	22	C2092	22	C2093	22
C2094	22	C2095	22	C2096	22
C2097	22	C2098	22	C2099	22
C2100	22	C2101	22	C2102	22

SCHEMATIC LOOKUP TABLE

XY PLOTTER BOARD DIAGRAM 22

ASSEMBLY NO.	CIRCUIT NUMBER	SCHEM NUMBER	CIRCUIT NUMBER	SCHEM NUMBER	CIRCUIT NUMBER	SCHEM NUMBER	CIRCUIT NUMBER	SCHEM NUMBER
2230	C2001	22	C2002	22	C2003	22	C2004	22
2230	C2005	22	C2006	22	C2007	22	C2008	22
2230	C2009	22	C2010	22	C2011	22	C2012	22
2230	C2013	22	C2014	22	C2015	22	C2016	22
2230	C2017	22	C2018	22	C2019	22	C2020	22
2230	C2021	22	C2022	22	C2023	22	C2024	22
2230	C2025	22	C2026	22	C2027	22	C2028	22
2230	C2029	22	C2030	22	C2031	22	C2032	22
2230	C2033	22	C2034	22	C2035	22	C2036	22
2230	C2037	22	C2038	22	C2039	22	C2040	22
2230	C2041	22	C2042	22	C2043	22	C2044	22
2230	C2045	22	C2046	22	C2047	22	C2048	22
2230	C2049	22	C2050	22	C2051	22	C2052	22
2230	C2053	22	C2054	22	C2055	22	C2056	22
2230	C2057	22	C2058	22	C2059	22	C2060	22
2230	C2061	22	C2062	22	C2063	22	C2064	22
2230	C2065	22	C2066	22	C2067	22	C2068	22
2230	C2069	22	C2070	22	C2071	22	C2072	22
2230	C2073	22	C2074	22	C2075	22	C2076	22
2230	C2077	22	C2078	22	C2079	22	C2080	22
2230	C2081	22	C2082	22	C2083	22	C2084	22
2230	C2085	22	C2086	22	C2087	22	C2088	22
2230	C2089	22	C2090	22	C2091	22	C2092	22
2230	C2093	22	C2094	22	C2095	22	C2096	22
2230	C2097	22	C2098	22	C2099	22	C2100	22

COMPONENT LOCATION TABLE

NUMERAL AND LETTER AT SIGNAL LINES TO OR FROM OTHER DIAGRAMS INDICATES THE GRID COORDINATES ON ANOTHER SCHEMATIC (FOR EXAMPLE: 8J)

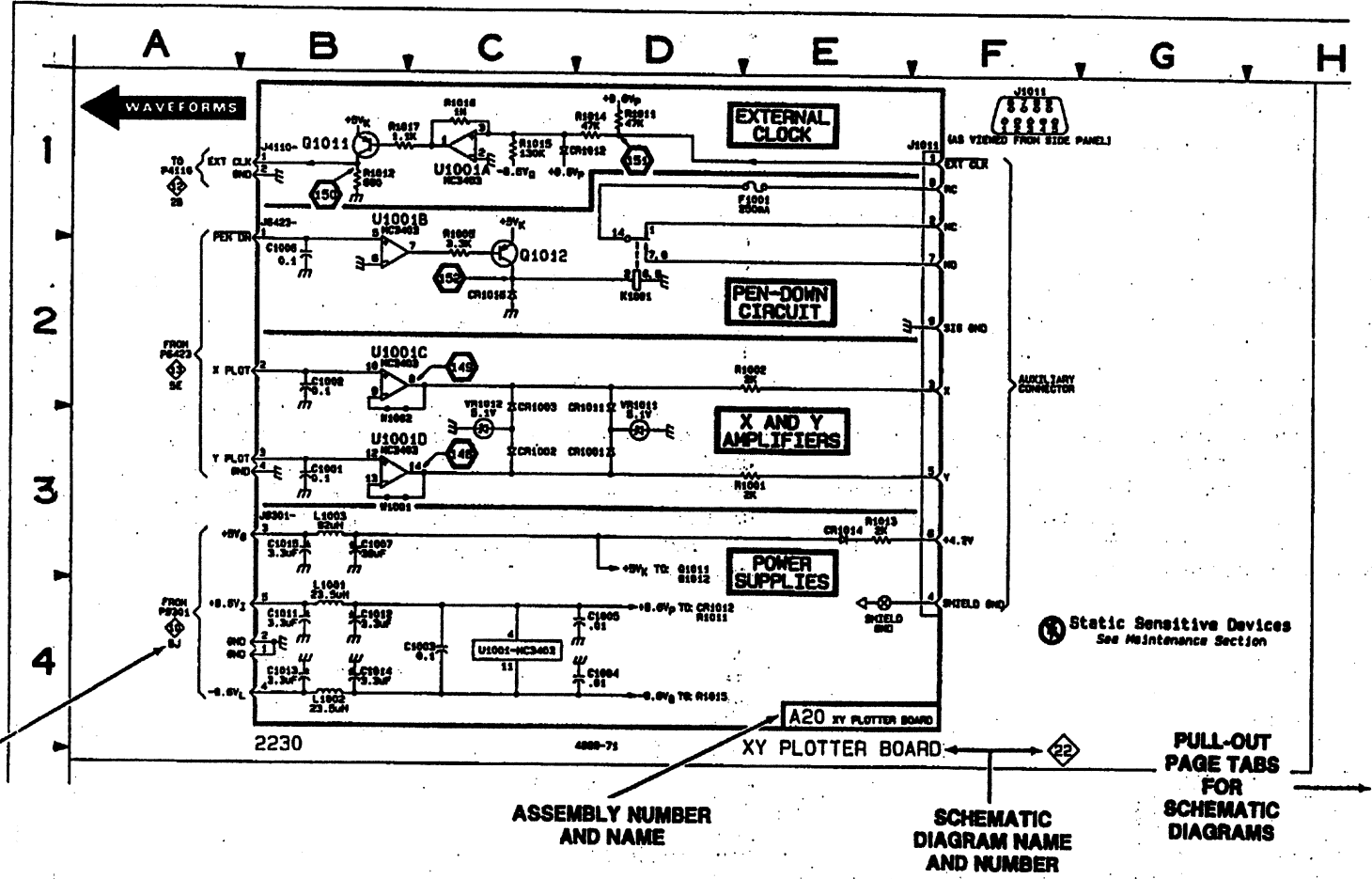

ASSEMBLY NUMBER AND NAME SCHEMATIC DIAGRAM NAME AND NUMBER

PULL-OUT PAGE TABS FOR SCHEMATIC DIAGRAMS

Identify any component in a schematic diagram and to locate that component on its respective circuit board.

1. Determine the Circuit Board Illustration and Component Location.
 - a. From the schematic diagram, determine the Assembly Number of the circuit board that the component is on. The Assembly Number and Name is boxed and located in a corner of the heavy line marking the circuit board outline in the schematic diagram.
 - b. Find the Component Location table for the Assembly Number found on the schematic. Scan the CIRCUIT NUMBER column to find the Circuit Number of the component.
 - c. Look in the BOARD LOCATION column next to the component number and read its circuit board grid coordinates.

2. Locate the Component on the Circuit Board.
 - a. In the manual, locate the tabbed page that corresponds to Assembly Number the component is on. Assembly numbers and names for circuit boards are on the back side of the tabs.
 - b. Using the Circuit Number of the component and its given grid location, find the component in the Circuit Board illustration.
 - c. From the small circuit board location illustration shown next to the circuit board, find the circuit board's location in the instrument.
 - d. Find the circuit board in the instrument. Compare it with the circuit board illustration in the manual to locate the component on the circuit board itself.

Figure 9-3. Locating components on schematic diagrams and circuit board illustrations.

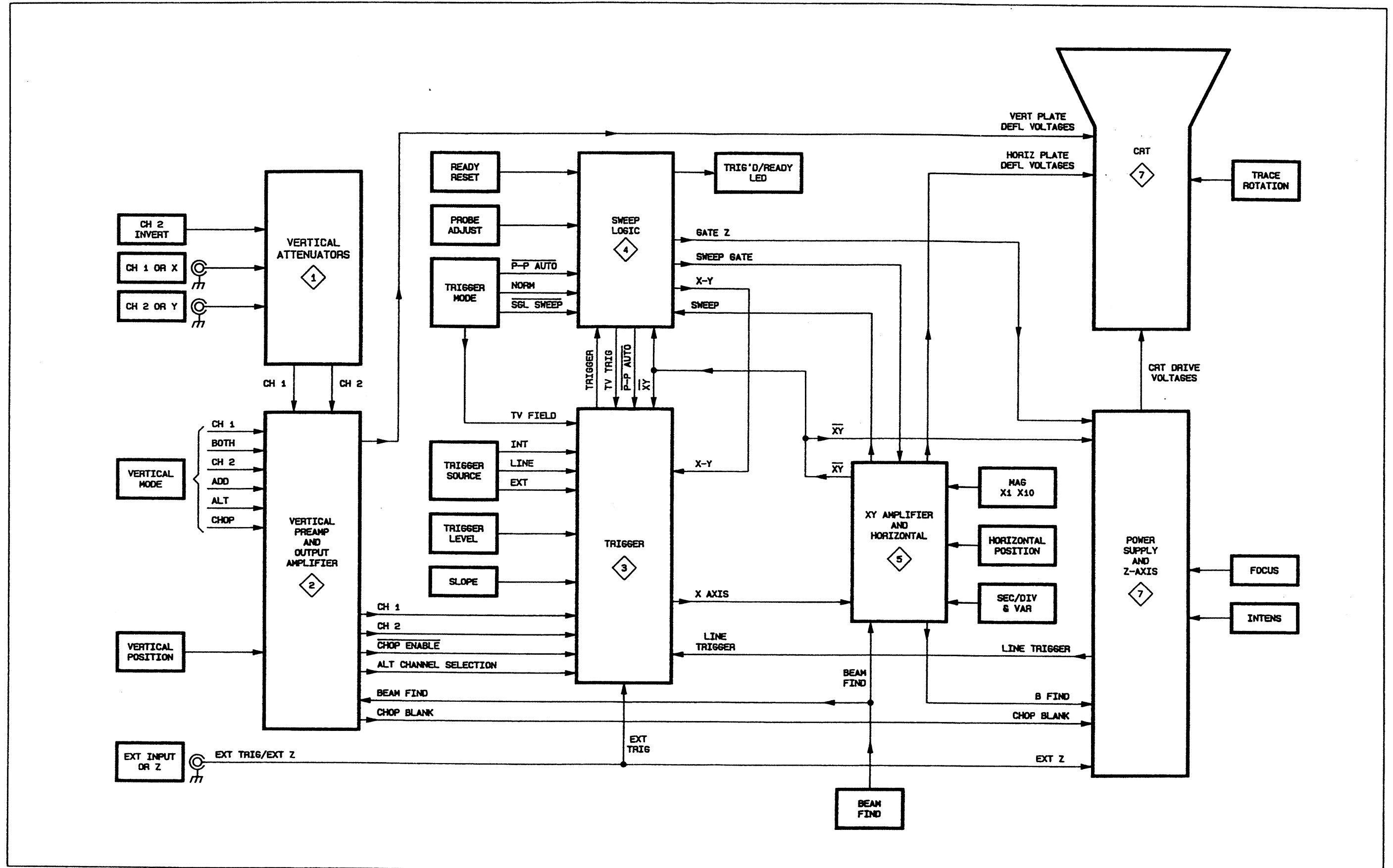

Figure 9-4. Block diagram.

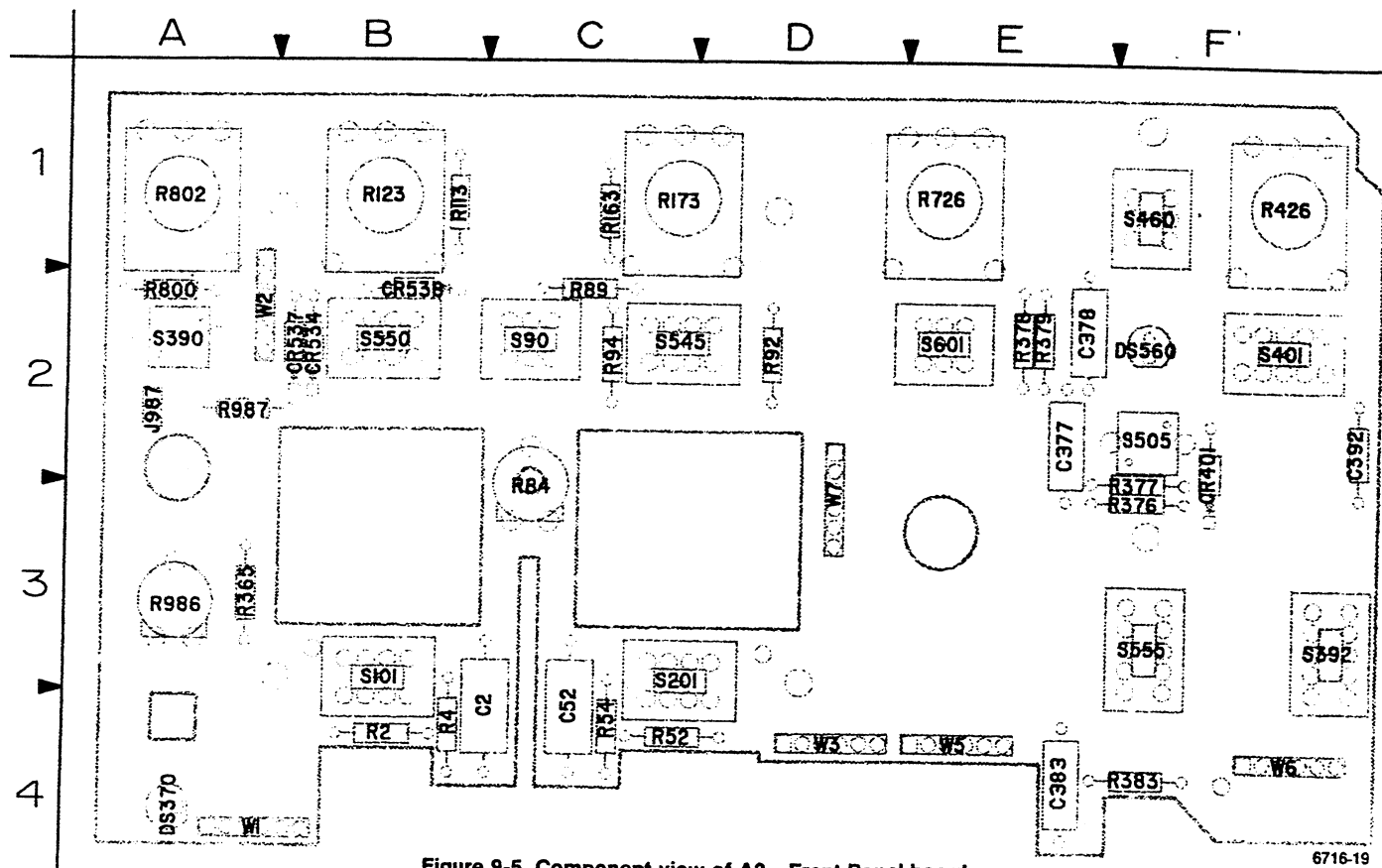
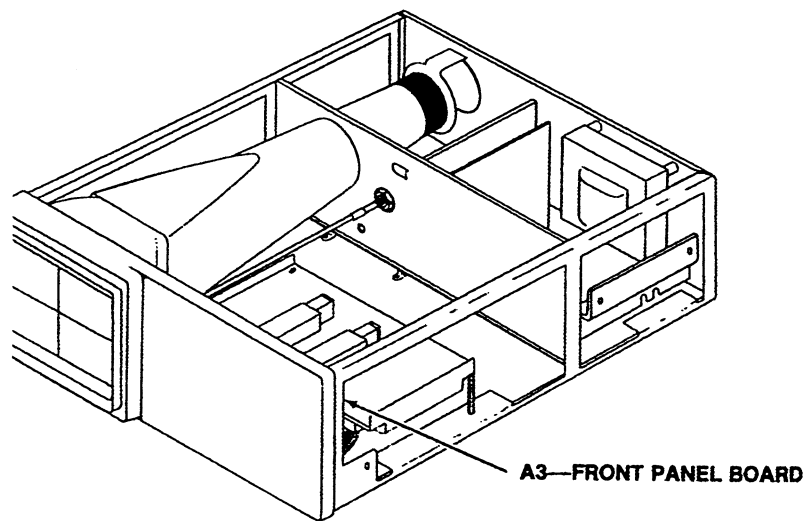

Figure 9-5. Component view of A3—Front Panel board.

6716-19

A3—FRONT PANEL BOARD					
CIRCUIT NUMBER	SCHEM NUMBER	CIRCUIT NUMBER	SCHEM NUMBER	CIRCUIT NUMBER	SCHEM NUMBER
C2	1	R84	6	S101	6
C2	6	R89	1	S201	1
C52	1	R89	6	S201	6
C52	6	R92	1	S390	6
C377	6	R92	6	S392	6
C378	6	R94	1	S401	6
C383	6	R94	6	S460	6
C392	6	R113	2	S505	4
		R113	6	S505	6
CR401	6	R123	2	S545	2
CR534	2	R123	6	S545	6
CR534	6	R163	2	S550	2
CR537	2	R163	6	S550	6
CR537	6	R173	2	S555	6
CR538	2	R173	6	S601	6
CR538	6	R365	6		
		R376	6	W1	2
DS370	6	R377	6	W1	4
DS560	4	R378	6	W1	6
DS560	6	R379	6	W2	2
		R383	6	W2	6
J987	6	R426	3	W3	3
		R426	6	W3	6
R2	1	R726	6	W3	8
R2	6	R800	6	W5	4
R4	1	R802	6	W5	6
R4	6	R986	6	W6	4
R52	1	R987	6	W6	6
R52	6			W7	1
R54	1	S90	1	W7	6
R54	6	S90	6		
R84	1	S101	1		



A3—FRONT PANEL BOARD

⊗ Static Sensitive Devices
See Maintenance Section

COMPONENT NUMBER EXAMPLE

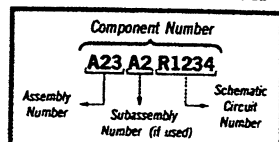

Chassis-mounted components have no Assembly Number prefix—see end of Replaceable Electrical Parts List

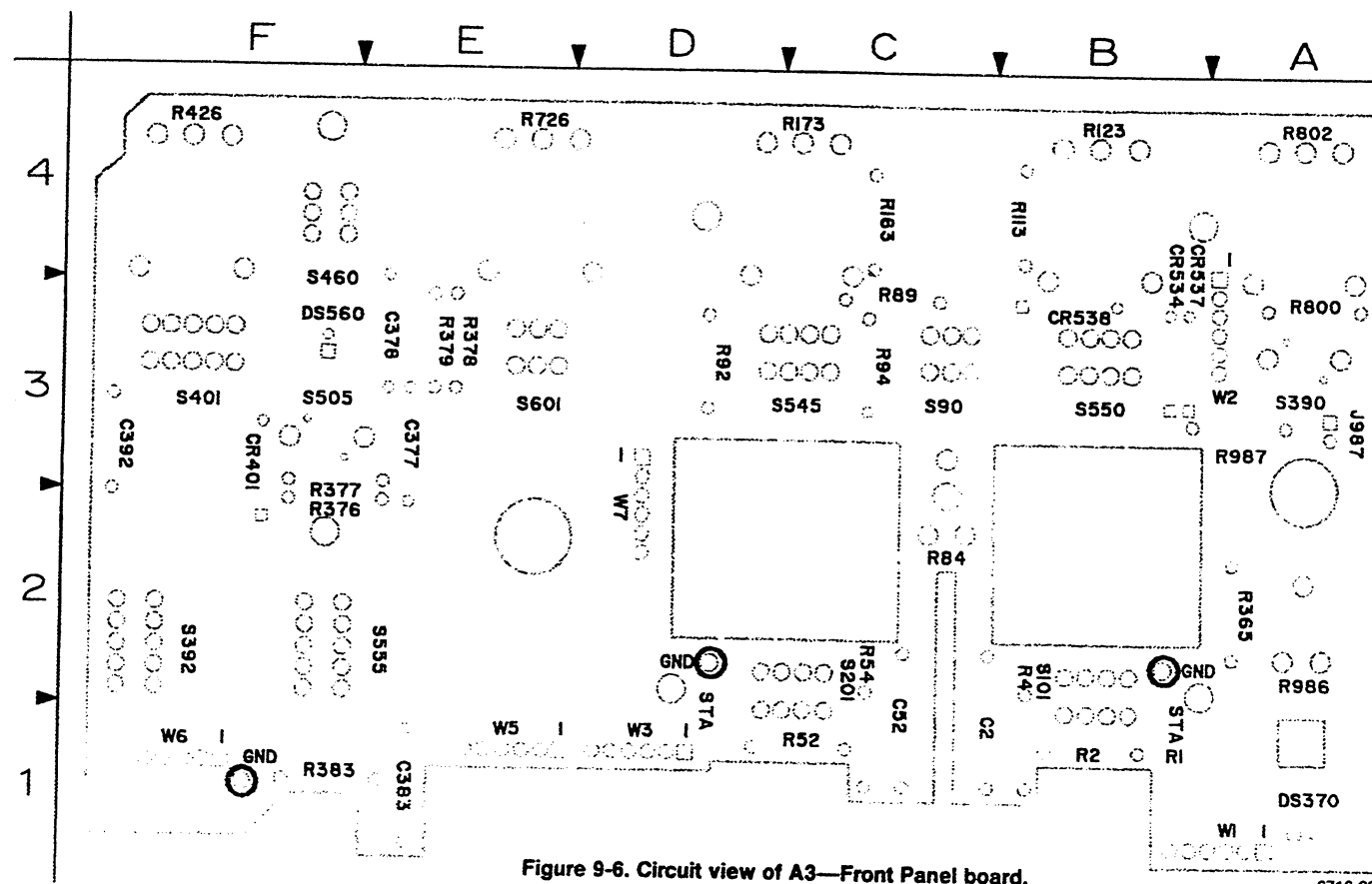

Figure 9-6. Circuit view of A3—Front Panel board.

6716-20

4

VOLTAGE/WAVEFORM SETUP CONDITIONS

WAVEFORMS

On the left-handed pages preceding the schematic diagrams are test waveform illustrations that are intended to aid in troubleshooting the instrument. To test the instrument for these waveforms, perform the Initial Measurements Setup procedure first. Changes to the Initial Measurement Setup are noted at the beginning of each set of waveforms.

Horizontal

POSITION	Midrange
MAG	X1
SEC/DIV	0.2 ms
SEC/DIV Variable	CAL detent

Trigger

SLOPE	Positive (↗)
MODE	P-P AUTO
SOURCE	VERT MODE

DC VOLTAGES

Typical voltage measurements located on the schematic diagrams were obtained with the instrument operating under the conditions specified in the Initial Measurements Setup procedure. Control-setting changes required for specific voltages are indicated on each waveform page. Voltage measurements are referenced to the chassis ground.

INITIAL MEASUREMENTS SETUP

To test the instrument for waveforms and voltages, set the initial control settings as follows:

Vertical (Both Channels)

POSITION	Midrange
MODE	CH 1, NORM
VOLTS/DIV	5 mV
VOLTS/DIV Variable	CAL detent
AC-GND-DC	GND

RECOMMENDED TEST EQUIPMENT

Test equipment in Table 4-1 in the Performance Check Procedure, Section 4, of this manual meets the required specifications for testing this instrument.

POWER SUPPLY ISOLATION PROCEDURE

Each regulated supply has numerous feed points to external loads through the instrument. Diagram 8, power distribution, is used in conjunction with the schematic diagrams to determine the service jumper or component that may be lifted to isolate loads from the power supply.

If a supply comes up after lifting one of the isolating jumpers, it is very probable that short exists in the circuitry on that supply line. By lifting jumpers or other components in the supply line farther down the line, the circuit in which a short exists may be located.

Always set the POWER switch to OFF before soldering or unsoldering service jumpers or other components and before attempting to measure component resistance values.

OTHER PARTS

CIRCUIT NUMBER	SCHEM NUMBER	CIRCUIT NUMBER	SCHEM NUMBER	CIRCUIT NUMBER	SCHEM NUMBER
J100	1	P902	7	R51	6
J100	6	P906	7	R382	6
J151	1	P910	7	R983	7
J151	6				
J300	6	R1	1	T901	7
J590	4	R1	6		
		R51	1	V900	7

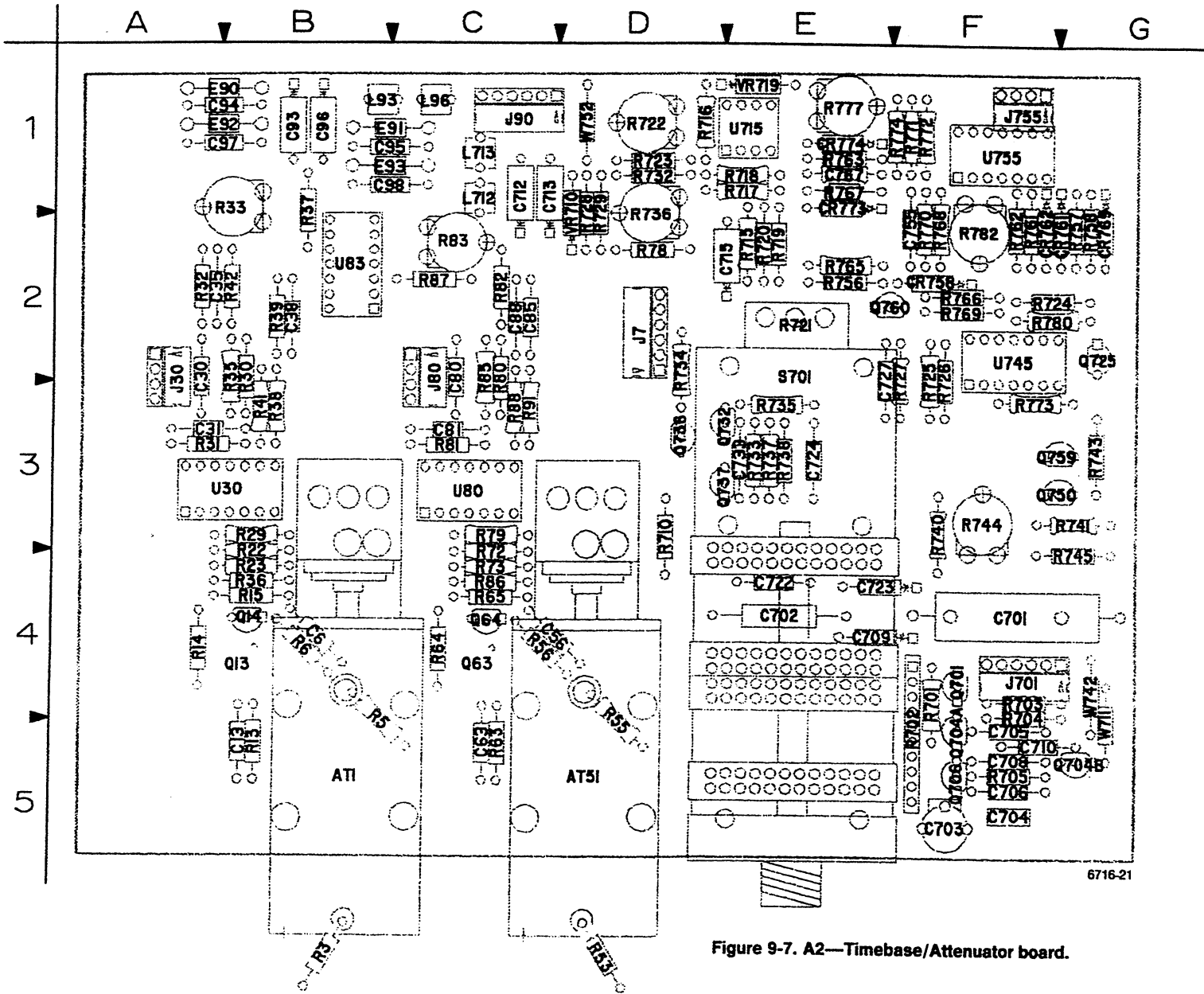
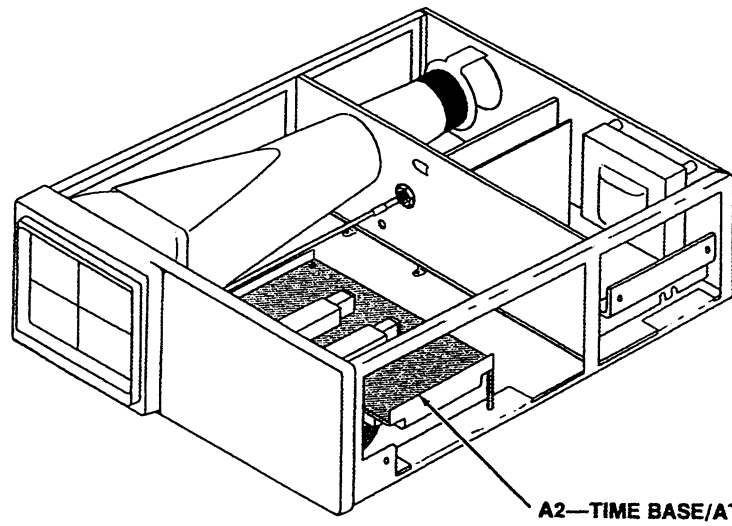

Figure 9-7. A2—Timebase/Attenuator board.

A2—TIMEBASE/ATTENUATOR BOARD							
CIRCUIT NUMBER	SCHEM NUMBER	CIRCUIT NUMBER	SCHEM NUMBER	CIRCUIT NUMBER	SCHEM NUMBER	CIRCUIT NUMBER	SCHEM NUMBER
AT1	1	E90	8	R30	1	R729	5
AT1	6	E91	1	R31	1	R732	5
AT51	1	E91	8	R32	1	R733	5
AT51	6	E92	1	R33	1	R734	5
		E92	8	R35	1	R735	5
C6	1	E93	1	R36	1	R736	5
C13	1	E93	8	R37	1	R737	5
C30	1			R38	1	R738	5
C31	1	J7	1	R39	1	R740	5
C35	1	J7	5	R41	1	R741	5
C38	1	J7	6	R42	1	R743	5
C56	1	J30	1	R53	1	R744	5
C63	1	J80	1	R53	6	R745	5
C80	1	J90	1	R55	1	R756	5
C81	1	J90	5	R56	1	R757	5
C85	1	J90	8	R63	1	R758	5
C88	1	J701	5	R64	1	R761	5
C93	1	J755	5	R65	1	R762	5
C94	1			R72	1	R763	5
C95	1	L93	1	R73	1	R765	5
C96	1	L96	1	R78	1	R766	5
C97	1	L712	5	R79	1	R767	5
C98	1	L712	8	R80	1	R768	5
C701	5	L713	5	R81	1	R769	5
C702	5	L713	8	R82	1	R770	5
C703	5			R83	1	R771	5
C704	5	Q13	1	R85	1	R772	5
C705	5	Q14	1	R86	1	R773	5
C706	5	Q63	1	R87	1	R774	5
C708	5	Q64	1	R88	1	R777	5
C709	5	Q701	5	R91	1	R780	5
C710	5	Q704	5	R701	5	R782	5
C712	5	Q706	5	R702	5		
C713	5	Q725	5	R703	5	S701	5
C715	5	Q732	5	R704	5		
C722	5	Q736	5	R705	5	U30	1
C723	5	Q737	5	R710	5	U80	1
C724	5	Q750	5	R715	5	U83	1
C727	5	Q759	5	R716	5	U715	5
C733	5	Q760	5	R717	5	U745	5
C755	5			R718	5	U755	5
C767	5	R3	1	R719	5		
		R3	6	R720	5	VR710	5
CR758	5	R5	1	R721	5	VR719	5
CR761	5	R6	1	R722	5		
CR762	5	R13	1	R723	5	W711	5
CR769	5	R14	1	R724	5	W742	5
CR773	5	R15	1	R725	5	W752	5
CR774	5	R22	1	R726	5		
		R23	1	R727	5		
E90	1	R29	1	R728	5		



A2—TIME BASE/ATTENUATOR BOARD

⊗ Static Sensitive Devices
See Maintenance Section

COMPONENT NUMBER EXAMPLE

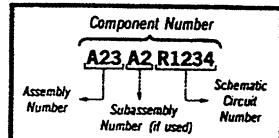

Chassis-mounted components have no Assembly Number prefix—see end of Replaceable Electrical Parts List.

VERTICAL ATTENUATORS DIAGRAM 1

ASSEMBLY A2											
CIRCUIT NUMBER	SCHEM LOCATION	BOARD LOCATION	CIRCUIT NUMBER	SCHEM LOCATION	BOARD LOCATION	CIRCUIT NUMBER	SCHEM LOCATION	BOARD LOCATION	CIRCUIT NUMBER	SCHEM LOCATION	BOARD LOCATION
AT1	1D	5B	E91	7C	1C	R13	1F	5B	R65	6F	4C
AT51	4D	5D	E92	7C	1B	R14	2F	4A	R72	6F	4C
			E93	8C	1B	R15	2F	4B	R73	5F	4C
C6	1E	4B	J7	7E	2D	R22	3F	4B	R78	6E	2D
C13	1F	5B	J7	7E	2D	R23	2F	4B	R79	6F	3C
C30	3E	2A	J7	7E	2D	R29	2F	3B	R80	6F	2C
C31	3F	3A	J30	1L	2A	R30	3F	2B	R81	6G	3C
C35	4H	2A	J80	5L	2C	R31	3F	3A	R82	6E	2C
C38	4J	2B	J90	7B	1C	R32	3E	2A	R83	6D	2C
C58	4E	4D				R33	3D	1B	R85	7G	2C
C63	4F	5C	L93	7B	1B	R35	4G	2B	R86	7G	4C
C80	6E	2C	L96	7B	1C	R36	4G	4B	R87	6H	2C
C81	6F	3C				R37	3H	1B	R88	7J	3C
C85	7G	2C	Q13A	1F	4B	R38	4J	3B	R91	7H	3C
C88	8J	2C	Q13B	2F	4B	R39	4J	2B			
C89	7B	1B	Q14	2E	4B	R41	4H	3B	U30	1G	3B
C94	7C	1B	Q83A	5F	4C	R42	4G	2B	U80	5G	3C
C95	7C	1C	Q83B	5F	4C	R53	5C	5D	U83A	5H	2B
C96	8B	1B	Q84	5E	4C	R55	5D	4D	U83B	5H	2B
C97	8C	1B				R56	5E	4C	U83C	2H	2B
C98	8C	1C	R3	2C	5B	R63	4F	5C	U83D	2H	2B
E90	7C	1B	R5	2D	4B	R64	5F	4C	U83E	4K	2B
			R6	2E	4B						

Partial A2 also shown on diagrams 5, 6 and 8.

ASSEMBLY A3											
CIRCUIT NUMBER	SCHEM LOCATION	BOARD LOCATION	CIRCUIT NUMBER	SCHEM LOCATION	BOARD LOCATION	CIRCUIT NUMBER	SCHEM LOCATION	BOARD LOCATION	CIRCUIT NUMBER	SCHEM LOCATION	BOARD LOCATION
C2	2B	4C	R52	5B	4C	R62	6F	2D	S101	2C	3B
C52	5B	4C	R54	5B	4C	R64	7F	2C	S201	5C	3C
R2	2B	4B	R89	7F	2C	S90	8E	2C	W7	7F	3D
R4	2B	4B									

Partial A3 also shown on diagrams 2, 3, 4, 6 and 8.

CHASSIS MOUNTED PARTS											
CIRCUIT NUMBER	SCHEM LOCATION	BOARD LOCATION	CIRCUIT NUMBER	SCHEM LOCATION	BOARD LOCATION	CIRCUIT NUMBER	SCHEM LOCATION	BOARD LOCATION	CIRCUIT NUMBER	SCHEM LOCATION	BOARD LOCATION
J100	2A	CHASSIS	J151	5A	CHASSIS	R1	2B	CHASSIS	R51	5B	CHASSIS

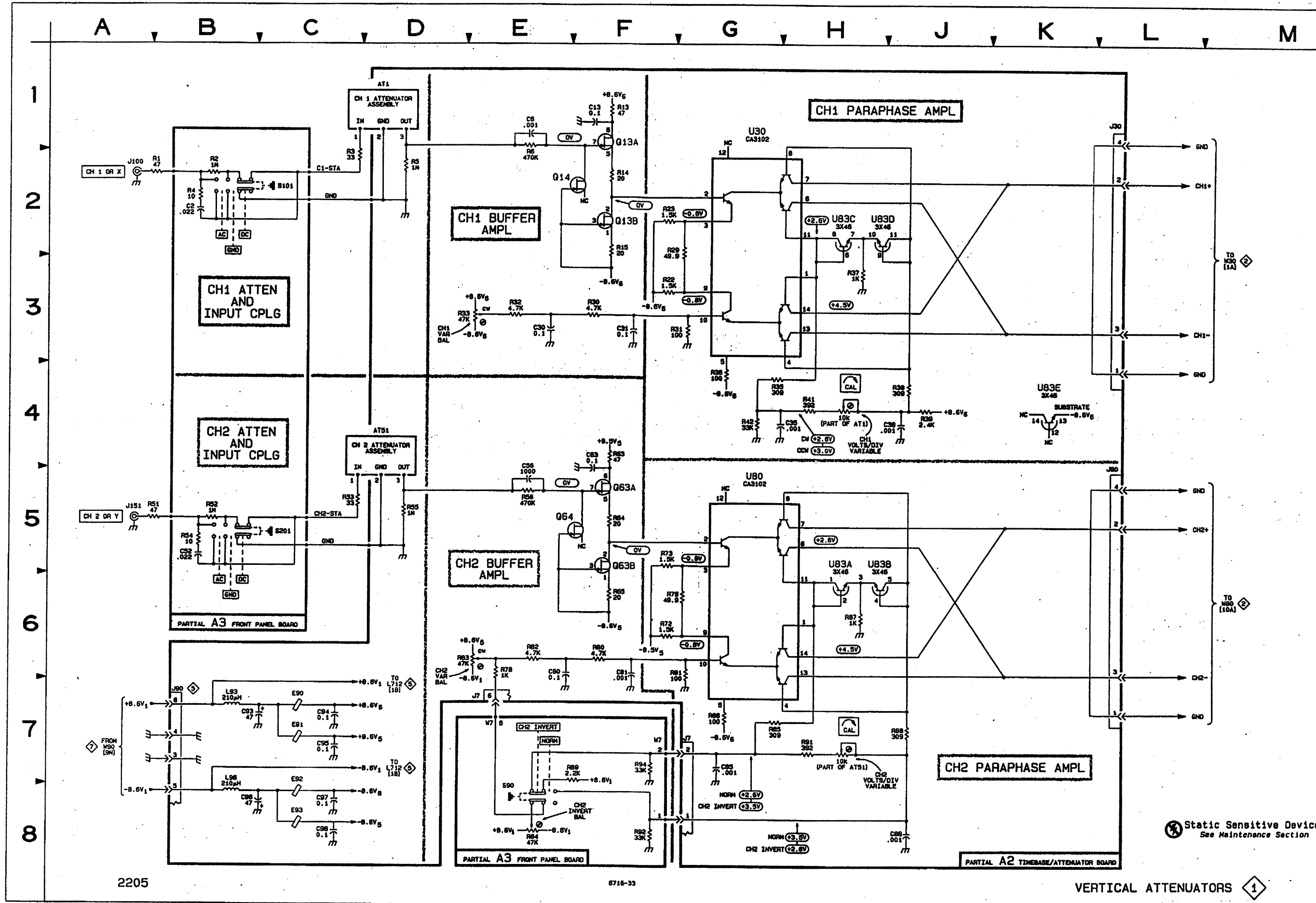

2205

6716-33

Static Sensitive Devices See Maintenance Section



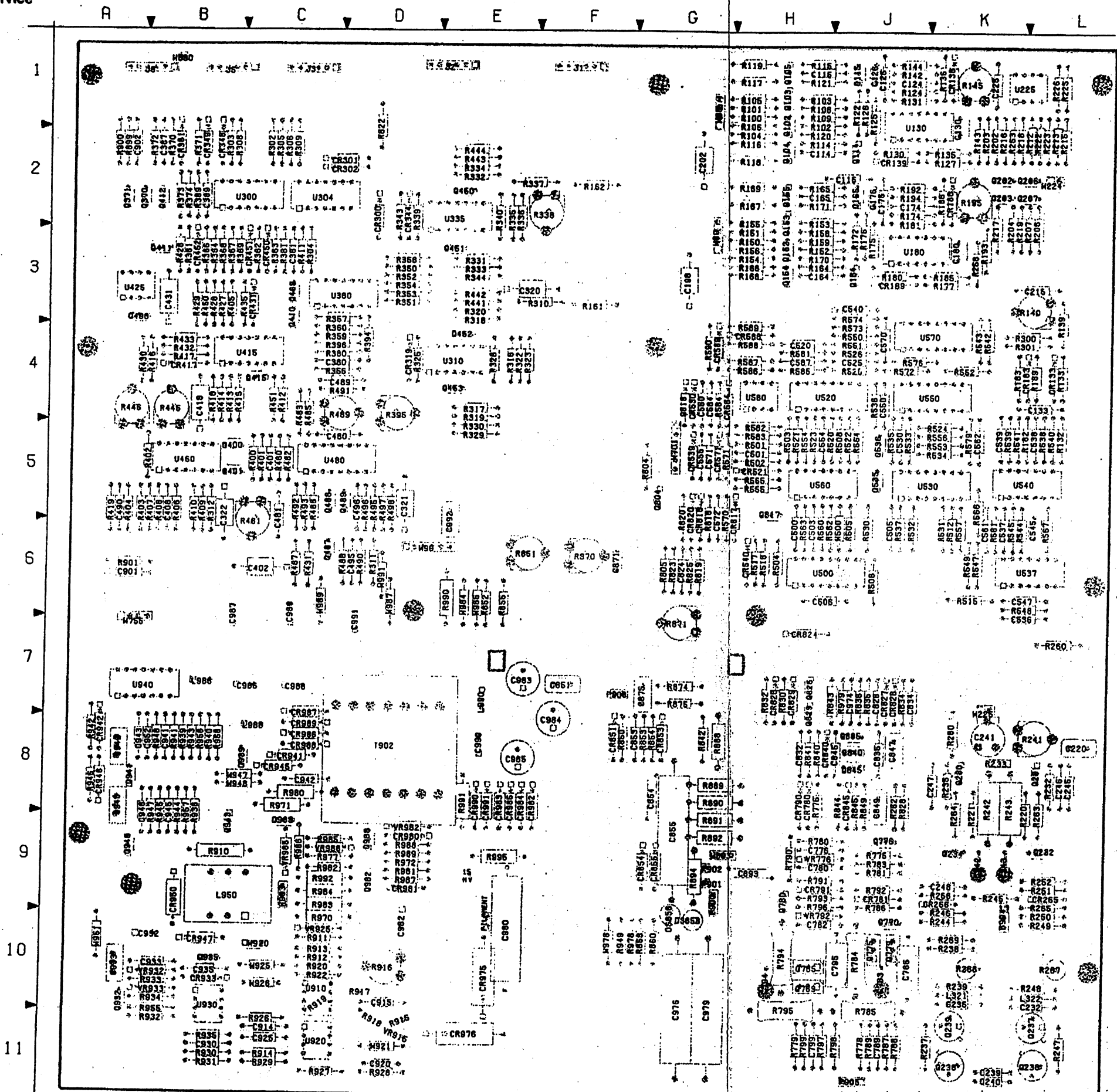
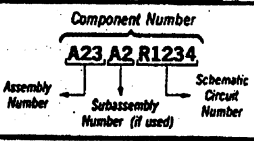

Figure 9-8. A1—Main board component view.

6716-22

⊗ Static Sensitive Devices
See Maintenance Section

COMPONENT NUMBER EXAMPLE



Chassis-mounted components have no Assembly Number prefix—see end of Replaceable Electrical Parts List.

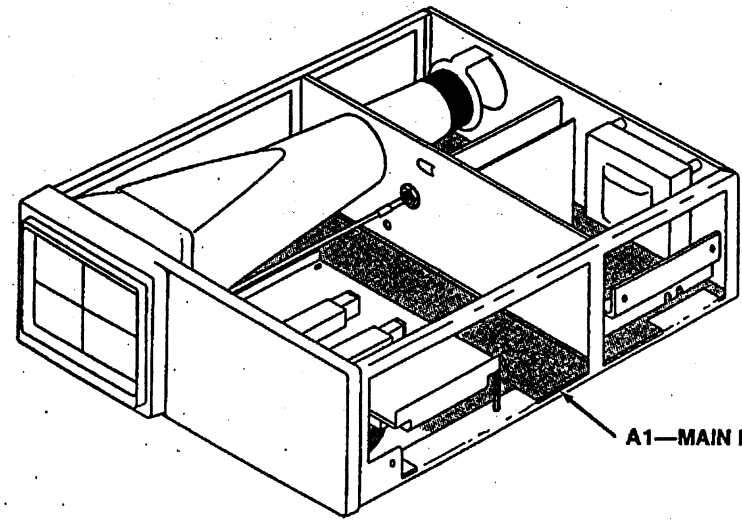

A1—MAIN BOARD

CIRCUIT NUMBER	SCHEM NUMBER	CIRCUIT NUMBER	SCHEM NUMBER	CIRCUIT NUMBER	SCHEM NUMBER	CIRCUIT NUMBER	SCHEM NUMBER	CIRCUIT NUMBER	SCHEM NUMBER	CIRCUIT NUMBER	SCHEM NUMBER
C114	2	C794	5	CR781	5	Q165	2	R126	2	R246	2
C115	2	C795	5	CR790	5	Q202	2	R127	2	R247	2
C116	2	C799	5	CR791	5	Q203	2	R130	2	R248	2
C124	2	C824	7	CR817	7	Q206	2	R131	2	R249	2
C125	2	C828	7	CR818	7	Q207	2	R132	2	R250	2
C126	2	C832	7	CR820	7	Q220	2	R133	2	R251	2
C130	2	C834	7	CR824	7	Q231	2	R135	2	R252	2
C133	2	C835	7	CR825	7	Q232	2	R136	2	R253	2
C164	2	C845	7	CR827	7	Q234	2	R139	2	R258	2
C185	2	C847	7	CR828	7	Q236	2	R140	2	R260	2
C174	2	C849	7	CR829	7	Q237	2	R142	2	R260	2
C175	2	C851	7	CR840	7	Q238	2	R143	2	R262	5
C176	2	C853	7	CR845	7	Q239	2	R144	2	R263	2
C180	2	C854	7	CR851	7	Q370	3	R145	2	R264	2
C198	2	C855	7	CR853	7	Q371	3	R150	2	R265	2
C202	2	C871	7	CR854	7	Q400	3	R151	2	R266	2
C215	2	C875	7	CR855	7	Q401	3	R152	2	R267	2
C220	2	C893	7	CR833	7	Q410	3	R153	2	R268	2
C225	2	C901	7	CR941	7	Q411	3	R154	2	R269	2
C232	2	C902	7	CR942	7	Q412	3	R155	2	R280	2
C235	2	C914	7	CR945	7	Q415	3	R156	2	R300	3
C239	2	C915	7	CR946	7	Q450	3	R158	2	R301	3
C240	2	C920	7	CR947	7	Q451	3	R159	2	R302	3
C241	2	C925	7	CR950	7	Q452	3	R161	2	R303	3
C242	2	C930	7	CR975	7	Q453	3	R161	8	R304	3
C243	2	C932	7	CR976	7	Q465	3	R162	2	R305	3
C245	2	C933	7	CR980	7	Q467	3	R162	8	R306	3
C246	2	C935	7	CR981	7	Q488	3	R164	2	R308	3
C247	2	C941	7	CR982	7	Q489	3	R165	2	R309	3
C248	2	C942	7	CR983	7	Q490	3	R166	2	R310	3
C320	3	C943	7	CR984	7	Q535	4	R167	2	R310	8
C321	3	C945	7	CR985	7	Q536	4	R168	2	R311	3
C322	3	C946	7	CR986	7	Q770	5	R168	2	R311	8
C380	3	C952	7	CR987	7	Q775	5	R170	2	R311	8
C381	3	C974	7	CR988	7	Q776	5	R171	2	R312	3
C387	3	C976	7	CR989	7	Q779	5	R172	2	R312	8
C389	3	C978	7	CR990	7	Q780	5	R174	2	R316	3
C401	3	C980	7	CR991	7	Q785	5	R175	2	R317	3
C402	3	C982	7			Q789	5	R176	2	R318	3
C408	3	C983	7	DS856	7	Q804	7	R177	2	R319	3
C418	3	C984	7	DS858	7	Q817	7	R177	2	R320	3
C431	3	C985	7			Q818	7	R180	2	R322	3
C480	3	C986	7	J1	2	Q818	7	R181	2	R323	3
C481	3	C987	7	J1	4	Q825	7	R182	2	R325	3
C489	3	C988	7	J1	6	Q829	7	R183	2	R326	3
C490	3	C989	7	J2	2	Q840	7	R185	2	R329	3
C495	3	C990	7	J2	6	Q845	7	R186	2	R330	3
C496	3	C991	7	J3	3	Q847	7	R188	2	R331	3
C500	4	C992	7	J3	6	Q832	7	R192	2	R332	3
C501	4			J3	8	Q833	7	R193	2	R333	3
C503	4	CR133	2	J5	4	Q835	7	R194	2	R334	3
C505	4	CR136	2	J5	6	Q839	7	R195	2	R335	3
C506	4	CR139	2	J6	4	Q841	7	R202	2	R336	3
C520	4	CR183	2	J6	6	Q842	7	R203	2	R337	3
C525	4	CR186	2			Q843	7	R204	2	R338	3
C530	4	CR189	2	L321	2	Q845	7	R208	2	R339	3
C536	2	CR265	2	L322	2	Q847	7	R207	2	R340	3
C537	2	CR266	2	L950	7	Q882	7	R212	2	R343	3
C538	2	CR300	3	L986	7	Q885	7	R213	2	R344	3
C539	2	CR301	3	L988	7	Q888	7	R215	2	R350	3
C540	2	CR302	3	L990	7			R216	2	R351	3
C545	2	CR319	3			R100	2	R217	2	R352	3
C547	2	CR344	3	P900	7	R101	2	R218	2	R353	3
C550	4	CR346	3	P901	7	R102	2	R219	2	R354	3
C554	4	CR349	3	P902	7	R103	2	R220	2	R356	3
C555	4	CR381	3	P903	7	R104	2	R221	2	R357	3
C560	4	CR417	3	P904	7	R105	2	R222	2	R358	3
C561	2	CR431	3	P905	5	R108	2	R223	2	R359	3
C562	2	CR450	3			R108	2	R225	2	R360	3
C570	4	CR451	3	Q102	2	R109	2	R226	2	R361	3
C571	4	CR452	3	Q103	2	R114	2	R232	2	R362	3
C572	4	CR521	4	Q104	2	R115	2	R233	2	R363	3
C584	4	CR530	4	Q105	2	R116	2	R235	2	R364	3
C587	4	CR539	2	Q114	2	R117	2	R237	2	R366	3
C776	5	CR540	4	Q115	2	R118	2	R238	2	R367	3
C780	5	CR571	4	Q152	2	R119	2	R239	2	R368	3
C782	5	CR584	4	Q153	2	R120	2	R241	2	R369	3
C783	5	CR588	4	Q154	2	R121	2	R242	2	R370	3
C785	5	CR589	4	Q155	2	R122	2	R243	2	R371	3
C789	5	CR780	5	Q164	2	R124	2	R244	2	R372	3
						R125	2	R245	2	R373	3

A1—MAIN BOARD (cont)

CIRCUIT NUMBER	SCHEM NUMBER	CIRCUIT NUMBER	SCHEM NUMBER	CIRCUIT NUMBER	SCHEM NUMBER	CIRCUIT NUMBER	SCHEM NUMBER	CIRCUIT NUMBER	SCHEM NUMBER	CIRCUIT NUMBER	SCHEM NUMBER
R374	3	R491	3	R562	4	R630	7	R936	7	U540	2
R380	3	R492	3	R563	4	R632	7	R939	7	U540	4
R381	3	R493	3	R564	4	R634	7	R940	7	U550	4
R389	3	R495	3	R565	4	R635	7	R941	7	U560	2
R384	3	R496	3	R566	2	R636	7	R942	7	U560	4
R395	3	R497	3	R567	2	R640	7	R943	7	U570	4
R398	3	R498	3	R570	4	R641	7	R944	7	U580	4
R400	3	R501	4	R571	4	R642	7	R945	7	U910	7
R401	3	R502	4	R572	4	R643	7	R946	7	U920	7
R402	3	R503	4	R573	4	R644	7	R947	7	U930	7
R403	3	R504	4	R574	4	R645	7	R948	7	U940	7
R404	3	R505	4	R576	4	R649	7	R949	7		
R405	3	R506	4	R579	4	R650	7	R955	7	VR776	5
R406	3	R508	4	R581	4	R651	7	R956	7	VR782	5
R407	3	R512	4	R582	4	R652	7	R957	7	VR915	7
R408	3	R515	4	R583	4	R653	7	R958	7	VR925	7
R409	3	R517	4	R584	4	R654	7	R970	7	VR932	7
R410	3	R518	4	R585	4	R655	7	R971	7	VR933	7
R411	3	R520	4	R586	4	R658	7	R972	7	VR982	7
R412	3	R521	4	R587	4	R660	7	R977	7	VR985	7
R413	3	R522	4	R588	4	R670	7	R978	7	VR988	7
R414	3	R523	4	R589	4	R671	7	R979	7		
R415	3	R524	4	R590	4	R674	7	R980	7	W30	2
R416	3	R525	4	R775	5	R675	7	R981	7	W80	2
R417	3	R528	4	R776	5	R688	7	R982	7	W90	7
R418	3	R530	4	R778	5	R689	7	R983	7	W90	8
R419	3	R531	4	R779	5	R690	7	R984	7	W224	2
R426	3	R532	4	R790	5	R691	7	R985	7	W225	2
R427	3	R533	4	R781	5	R692	7	R986	7	W500	4
R428	3	R534	4	R783	5	R694	7	R987	7	W590	4
R429	3	R535	4	R784	5	R699	7	R988	7	W701	4
R430	3	R536	4	R785	5	R900	7	R989	7	W755	5
R431	3	R537	4	R786	5	R901	7	R990	7	W893	7
R431	8	R538	2	R787	5	R910	7	R991	7	W903	7
R432	3	R539	2	R788	5	R911	7	R992	7	W920	7
R433	3	R540	2	R789	5	R912	7	R995	7	W921	7
R435	3	R541	2	R790	5	R913	7	T902	7	W925	7
R441	3	R542	3	R791	5	R914	7			W926	7
R442	3	R543	3	R792	5	R915	7			W947	7
R443	3	R544	2	R793	5	R916	7	U130	2	W948	7
R444	3	R545	2	R794	5	R917	7	U180	2	W951	7
R445	3	R546	2	R795	5	R918	7	U225	2	W976	7
R446	3	R547	2	R796	5	R919	7	U300	3	W984	7
R450	3	R548	2	R797	5	R920	7	U304	3	W984	8
R451	3	R549	2	R798	5	R922	7	U310	3	W985	7
R460	3	R550	4	R799	5	R926	7	U335	3	W987	7
R481	3	R551	4	R804	7	R927	7	U380	3	W987	8
R482	3	R552	4	R806	7	R928	7	U415	3	W989	7
R483	3	R553	4	R818	7	R929	7	U425	3	W989	8
R485	3	R554	4	R819	7	R930	7	U460	3	W991	7
R486	3	R555	4	R820	7	R931	7	U480	3	W991	8
R487	3	R556	4	R822	7	R932	7	U500	4		
R488	3	R557	4	R823	7	R933	7	U520	4		
R489	3	R560	4	R825	7	R934	7	U530	4		
R490	3	R561	2	R828	5	R935	7	U537	2		

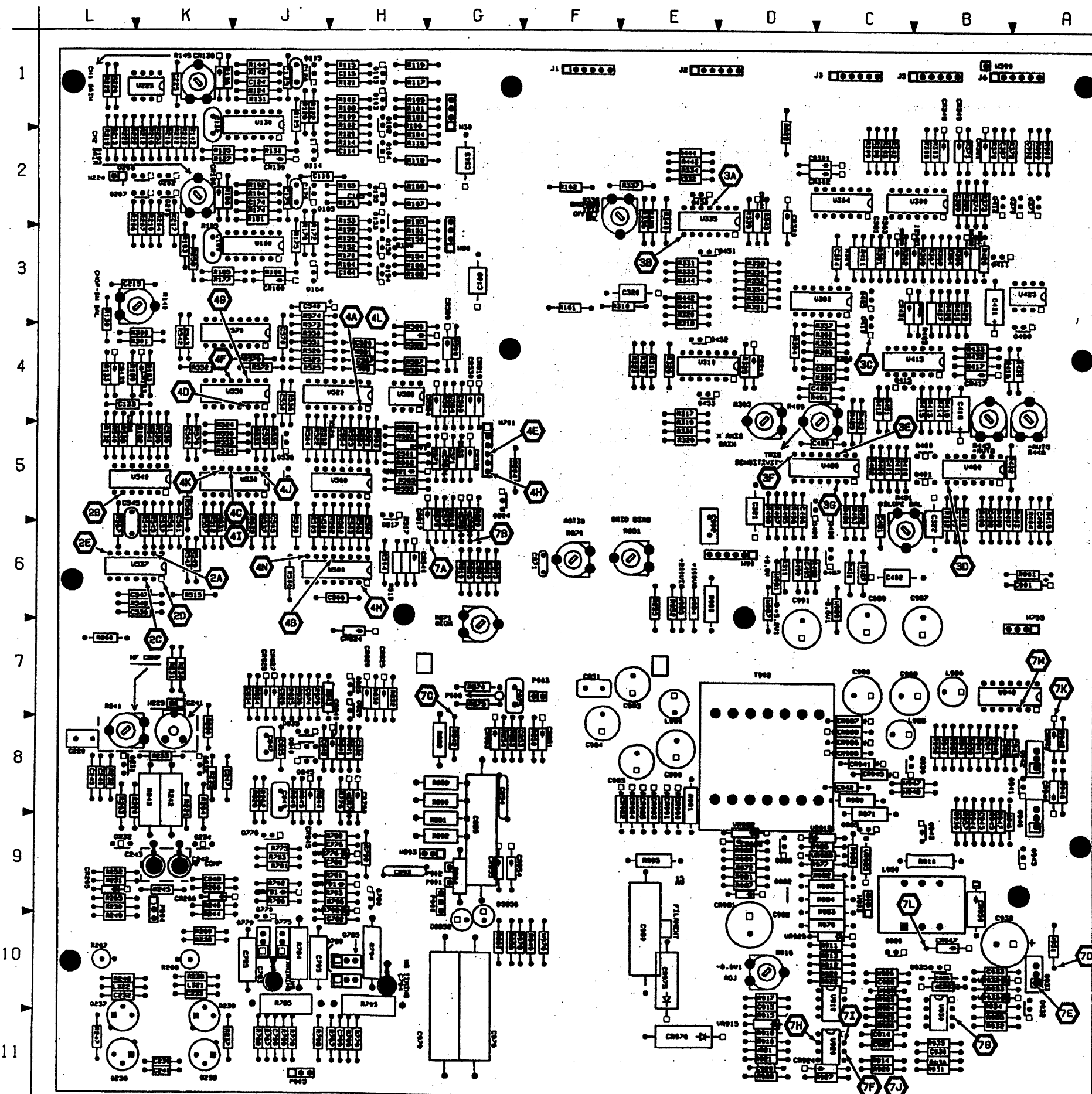
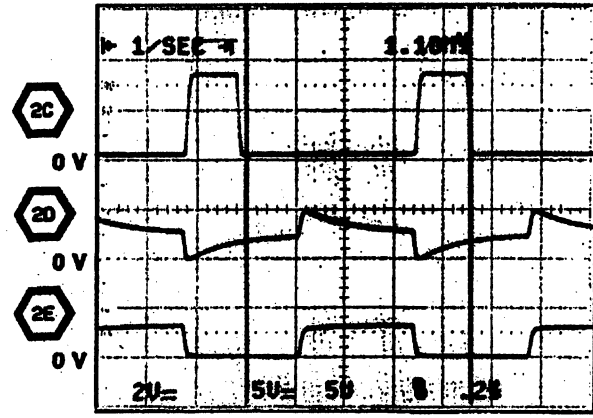
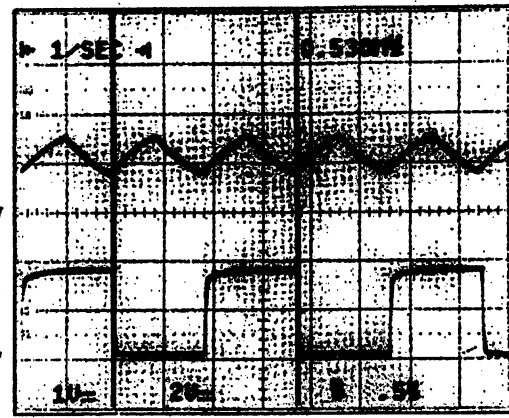

Figure 9-9. Circuit view of A1—Main board.

WAVEFORMS FOR DIAGRAM 2

AC Waveforms
VERTICAL MODE BOTH and CHOP



6716-29

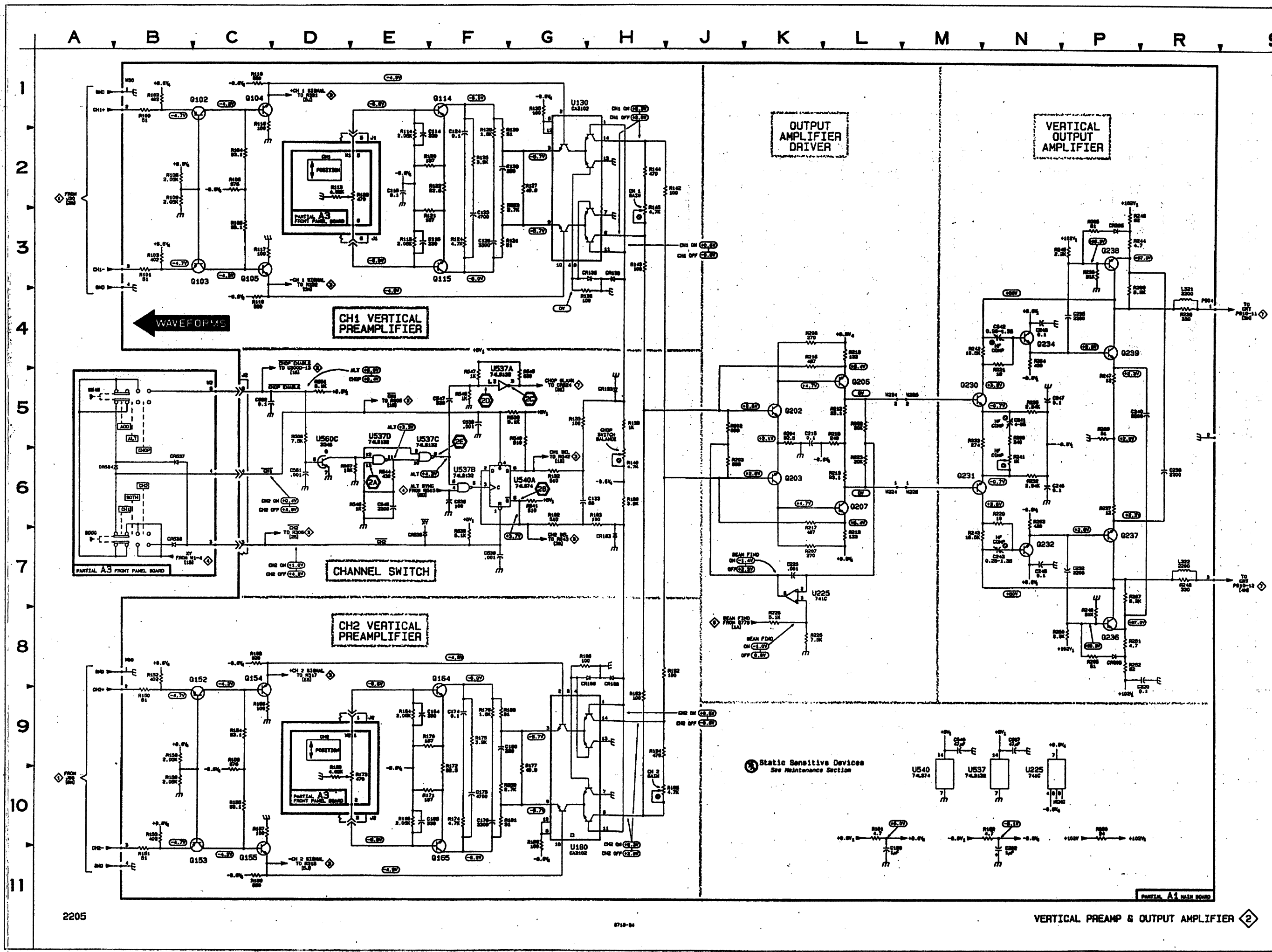

WAVEFORMS FOR DIAGRAM 3

AC Waveforms

VOLTS/DIV 0.1 V
 AC-GND-DC AC
 SEC/DIV 5μs
 Input signal 4-division, 50 kHz reference sine wave

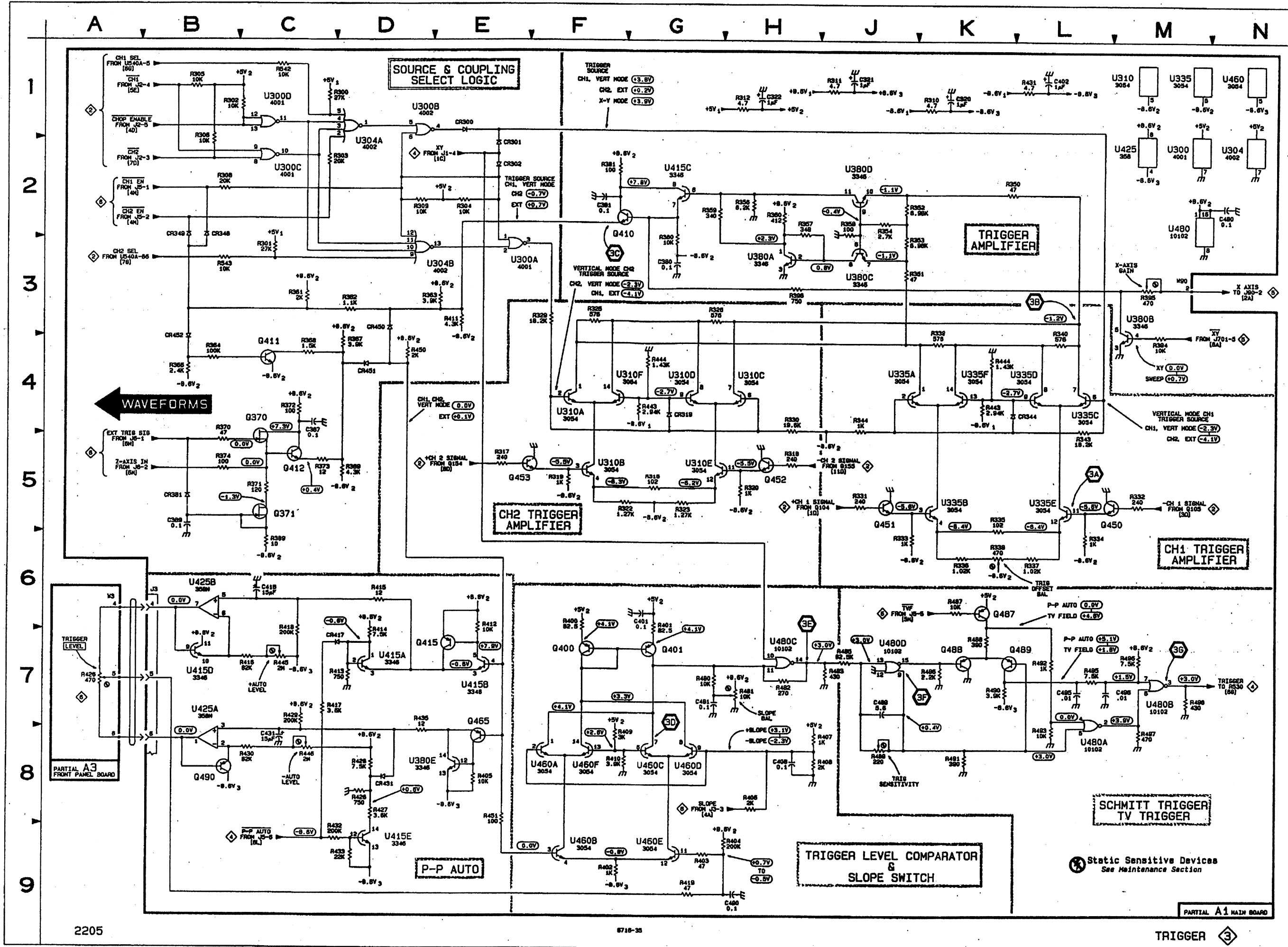
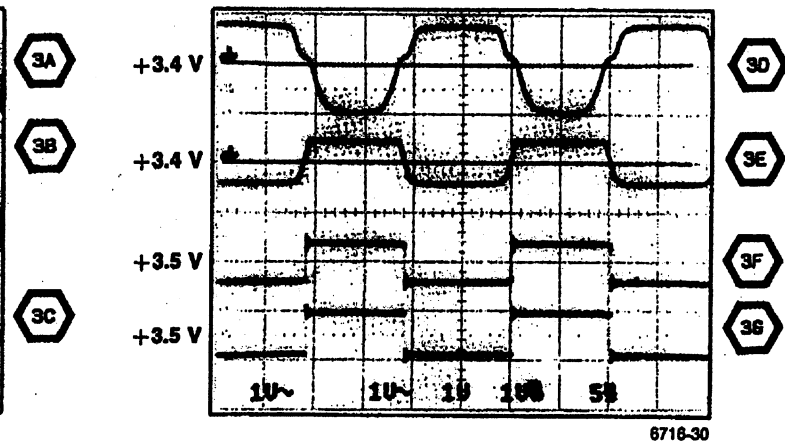
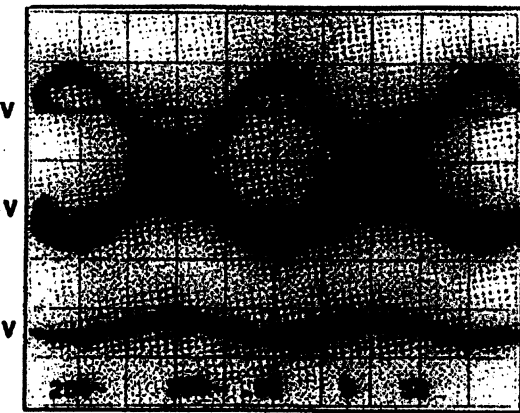

SWEEP LOGIC DIAGRAM 4

ASSEMBLY A1											
CIRCUIT NUMBER	SCHEM LOCATION	BOARD LOCATION	CIRCUIT NUMBER	SCHEM LOCATION	BOARD LOCATION	CIRCUIT NUMBER	SCHEM LOCATION	BOARD LOCATION	CIRCUIT NUMBER	SCHEM LOCATION	BOARD LOCATION
C500	1F	6H	C535	3J	6J	R552	7H	4K	U500	1F	6H
C501	4B	6H	C536	3J	6J	R553	5H	5K	U520A	4D	4H
C503	6C	6H				R554	6J	6H	U520B	4E	4H
C505	3C	6H	R501	4B	5H	R555	2D	6J	U520C	4F	4H
C506	6J	6H	R502	5B	5H	R556	4Q	5K	U520D	7D	4H
C520	3D	6H	R503	5B	5H	R557	4E	6K	U520	1Q	4H
C525	7D	4H	R504	6J	6H	R558	6J	6H	U530A	2F	6J
C530	1H	6J	R505	2C	6J	R559	6K	6J	U530B	3H	6J
C550	1I	6J	R506	3C	6J	R560	5K	6H	U530	1H	6J
C554	1D	5H	R508	6E	6J	R564	2C	6J	U540B	3Q	6K
C555	2D	5G	R512	9C	6K	R565	2E	6H	U520A	6J	4J
C560	6L	4G	R515	6B	6H	R570	4K	6Q	U560B	6H	4J
C570	1K	4J	R517	6B	6H	R571	4L	6G	U530C	4F	4J
C571	4L	6J	R518	6B	6H	R572	7E	4J	U560D	7Q	4J
C572	3K	6Q	R520	4C	6J	R573	7F	4J	U560	1H	4J
C584	7B	4G	R521	4C	6J	R574	7F	3J	U580A	6J	6H
C587	7J	4H	R522	4F	6J	R578	7G	4J	U580B	6K	6H
			R523	4D	6H	R579	6E	5K	U580D	1E	6H
CR621	4C	6H	R524	5G	6K	R581	7C	4H	U580E	6C	6H
CR630	2D	4G	R525	7C	4J	R582	6B	5H	U570A	7E	4J
CR640	2D	6H	R526	7C	4J	R583	6B	6H	U570B	6G	4J
CR571	4L	6G	R530	6G	6J	R584	7B	4G	U570	1J	4J
CR584	7B	4G	R531	3D	6K	R585	7J	4H	U580A	7J	4H
CR588	7K	4H	R532	3G	6J	R586	7K	4H	U580B	7B	4H
CR590	7L	4G	R533	3H	6J	R587	7K	4H			
			R534	4J	6K	R588	7K	4H	W500	5B	6J
J1	1B	1F	R535	4J	6J	R589	7K	4H	W590	7L	1B
J5	2C	1B	R537	4J	6J	R590	7L	4G	W701	3L	5G
J5	6L	1B	R538	3J	6J						
J6	6L	1A	R550	6J	4J	U500A	4D	6H			
			R551	6G	4J	U500B	6C	6H			

Partial A1 also shown on diagrams 2, 3, 5, 6, 7 and 8.

ASSEMBLY A3											
CIRCUIT NUMBER	SCHEM LOCATION	BOARD LOCATION	CIRCUIT NUMBER	SCHEM LOCATION	BOARD LOCATION	CIRCUIT NUMBER	SCHEM LOCATION	BOARD LOCATION	CIRCUIT NUMBER	SCHEM LOCATION	BOARD LOCATION
DS500	6M	2F	S606	2B	2F	W1	1B	4A	W5	6L	4E
						W5	2B	4E	W5	6L	4F

Partial A3 also shown on diagrams 1, 2, 3, 6 and 8.

CHASSIS MOUNTED PARTS											
CIRCUIT NUMBER	SCHEM LOCATION	BOARD LOCATION	CIRCUIT NUMBER	SCHEM LOCATION	BOARD LOCATION	CIRCUIT NUMBER	SCHEM LOCATION	BOARD LOCATION	CIRCUIT NUMBER	SCHEM LOCATION	BOARD LOCATION
J590	7L	CHASSIS									

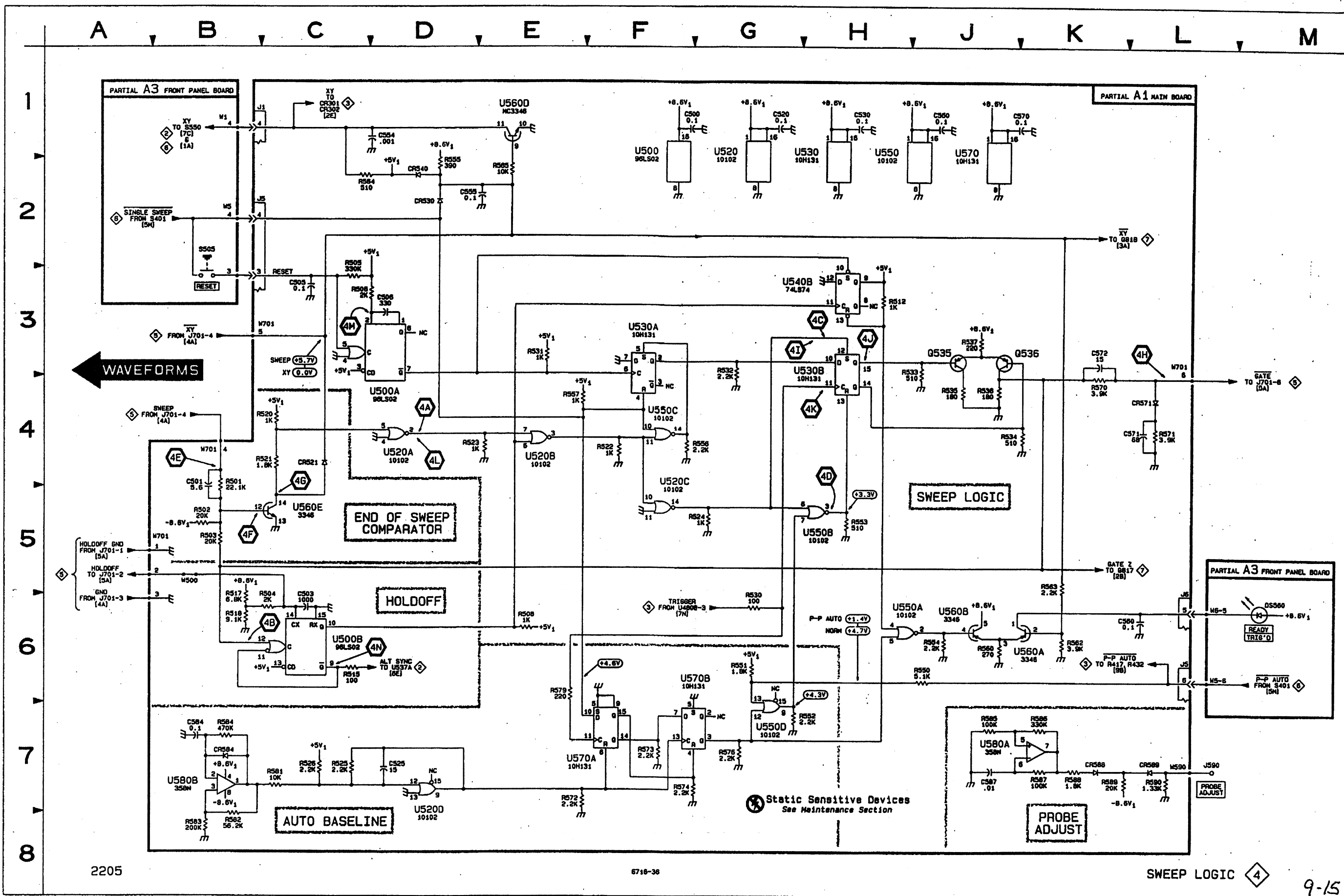

2205

6716-36

SWEEP LOGIC 4

SWEEP GENERATOR & HORIZONTAL AMPLIFIER DIAGRAM 5

ASSEMBLY A1											
CIRCUIT NUMBER	SCHEM LOCATION	BOARD LOCATION	CIRCUIT NUMBER	SCHEM LOCATION	BOARD LOCATION	CIRCUIT NUMBER	SCHEM LOCATION	BOARD LOCATION	CIRCUIT NUMBER	SCHEM LOCATION	BOARD LOCATION
C776	2K	8H	P805	2M	11J	R770	2M	11H	R783	4K	8H
C780	2L	8H				R780	1K	8H	R784	3L	10H
C782	2L	10H	Q770	1L	10J	R781	1L	8J	R785	3L	10H
C783	2L	10J	Q775	2M	10J	R783	2K	8J	R787	4M	8H
C785	1M	13B	Q776	4K	8J	R784	2L	10J	R787	4M	11J
C789	1M	11J	Q779	1M	10J	R785	2L	10J	R788	3M	11J
C794	4L	10H	Q780	3L	10H	R788	3L	8J	R789	3M	11H
C795	3M	10J	Q785	4M	10H	R787	1M	11J	R828	4J	8J
C799	3M	11H	Q789	3M	10H	R789	2M	11J	VR776	2K	8H
CR780	1K	8H	R282	4K	8J	R790	3K	8H	VR782	3L	10H
CR781	2L	8J	R775	3K	8J	R791	3L	8H	W755	1J	7A
CR780	3K	8H	R778	2K	8H	R792	3L	8J			
CR791	2L	8H	R779	2M	11J	R792	3L	8J			

Partial A1 also shown on diagrams 2, 3, 4, 6, 7 and 8.

ASSEMBLY A2											
CIRCUIT NUMBER	SCHEM LOCATION	BOARD LOCATION	CIRCUIT NUMBER	SCHEM LOCATION	BOARD LOCATION	CIRCUIT NUMBER	SCHEM LOCATION	BOARD LOCATION	CIRCUIT NUMBER	SCHEM LOCATION	BOARD LOCATION
C701	8B	4F	J755	1H	1F	R722	7F	1D	R788	8H	2F
C702	7B	4E				R723	7L	2D	R770	8H	2F
C703	4C	5F	L712	1B	1C	R724	7L	2D	R771	8J	1F
C704	4C	5F	L713	1B	1C	R725	8M	3F	R772	8J	1F
C705	4D	5F				R726	2F	3F	R773	8J	3F
C706	5D	5F	Q701	5B	4F	R727	2F	3F	R774	8L	1F
C708	5D	5F	Q704A	5D	4F	R728	3B	2D	R777	7K	1E
C709	5C	4E	Q704B	5D	5G	R729	3C	2D	R780	7M	2F
C710	1C	5F	Q708	5D	5F	R732	2D	1D	R782	6K	2F
C712	1C	1C	Q725	8L	2G	R733	2E	3E	S701	8C	2E
C713	1C	1C	Q732	3D	3E	R734	3D	2D			
C715	8E	2E	Q736	3D	3E	R735	2C	3E			
C722	8B	4E	Q737	2F	3E	R736	1D	1D	U715A	8E	1E
C723	5D	4E	Q750	4Q	3G	R737	2F	3E	U745A	8J	2F
C724	2F	3E	Q759	4Q	3Q	R740	4E	3F	U745B	8K	2F
C727	2G	3E	Q760	7H	2F	R741	4F	3Q	U745D	7L	2F
C733	2E	3E				R743	7G	3Q	U745E	8H	2F
C755	8J	2F	R701	8E	4F	R744	4E	3F	U755A	8L	1F
C767	7K	1E	R702	8E	5F	R745	4G	4Q	U755B	8L	1F
CR758	8G	2F	R704	4B	4F	R746	5K	2G	U755C	8J	1F
CR761	7K	2G	R705	5D	5F	R747	5K	2G	U755D	8L	1F
CR762	8K	2F	R710	3E	3D	R748	6K	2G	U755E	8J	1F
CR769	8K	2G	R715	8E	2E	R749	6K	2F			
CR773	7K	1E	R716	7E	1D	R751	6K	2F	VR710	2B	1D
CR774	7L	1E	R717	8F	1E	R752	7K	1E	VR719	8F	1E
J7	1F	2D	R718	8E	1E	R753	7K	1E	W711	5D	4G
J90	2B	1C	R719	8F	2E	R756	8G	2E	W742	4D	4G
J701	3B	4	R720	8F	2E	R757	7K	1E	W752	3B	1D
			R721	7F	2E	R758	7H	2F			

Partial A2 also shown on diagrams 1, 6 and 8.

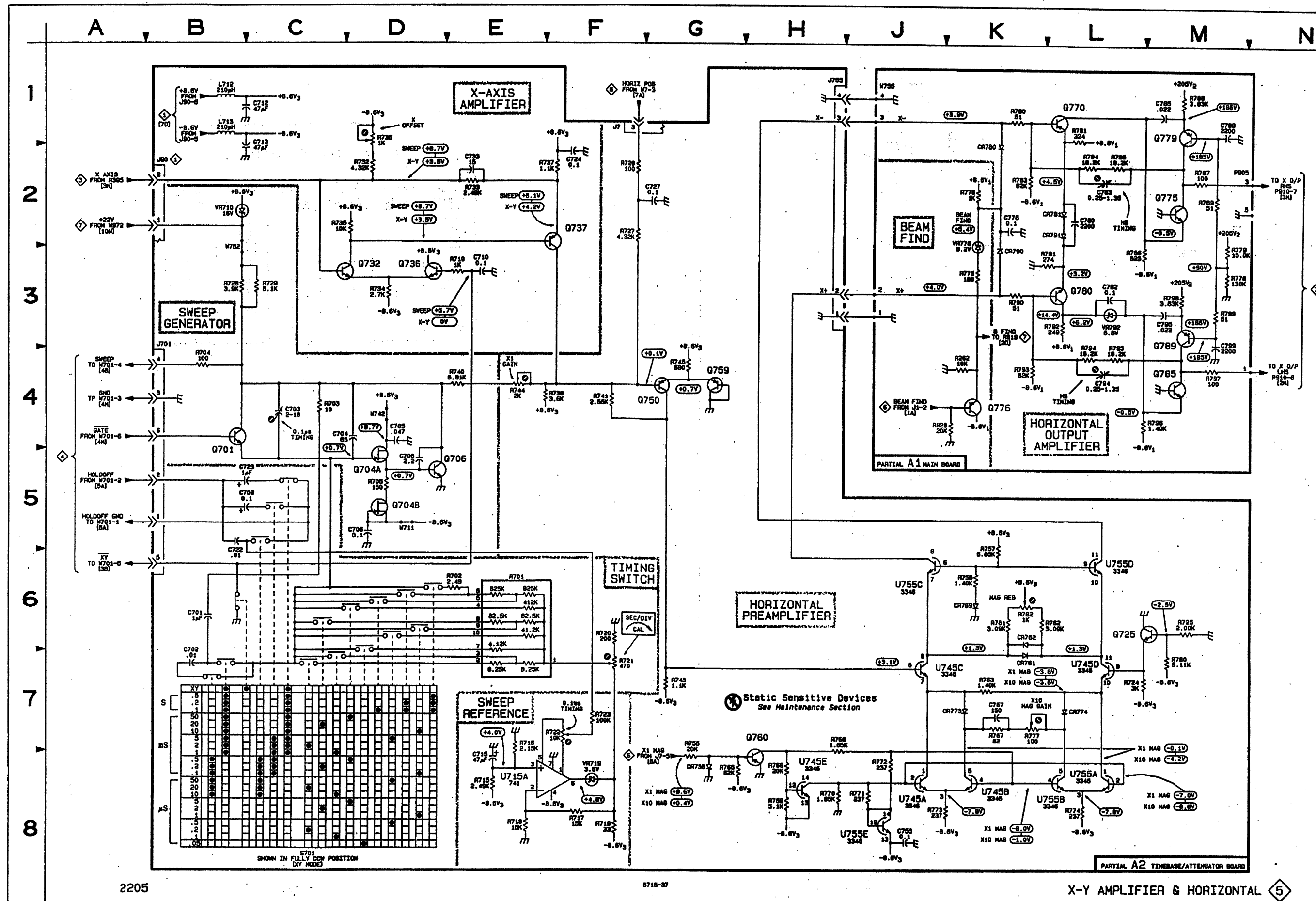

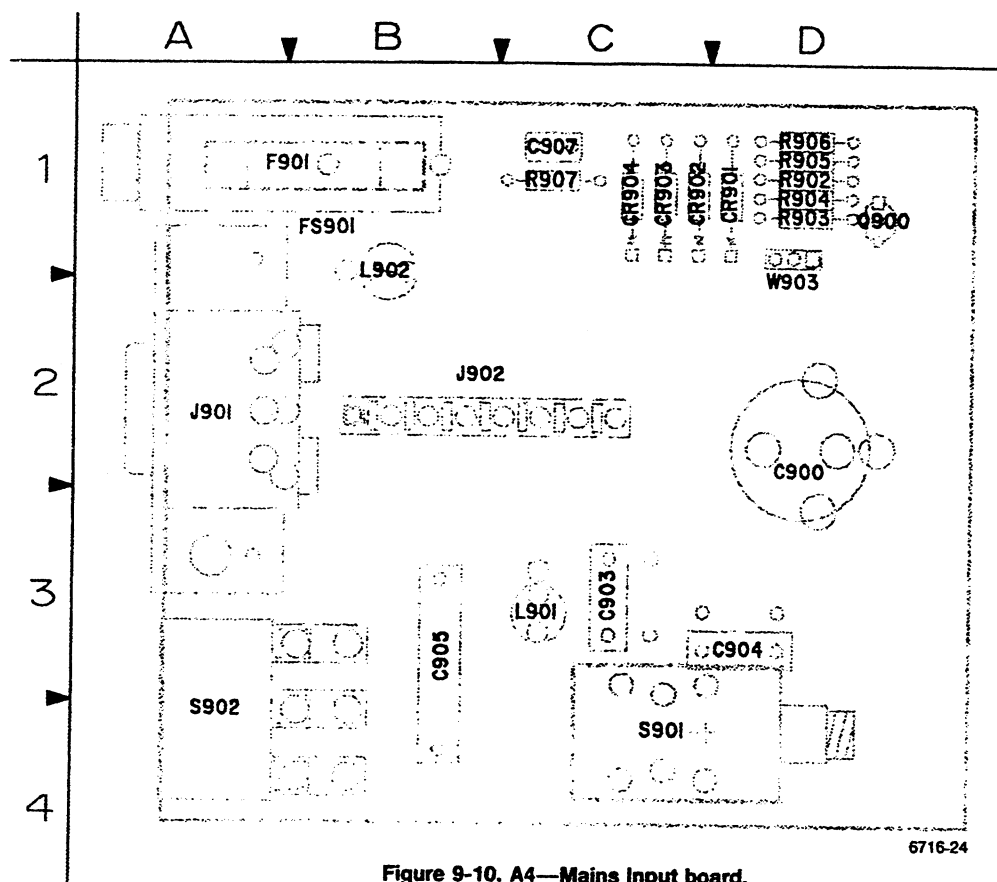
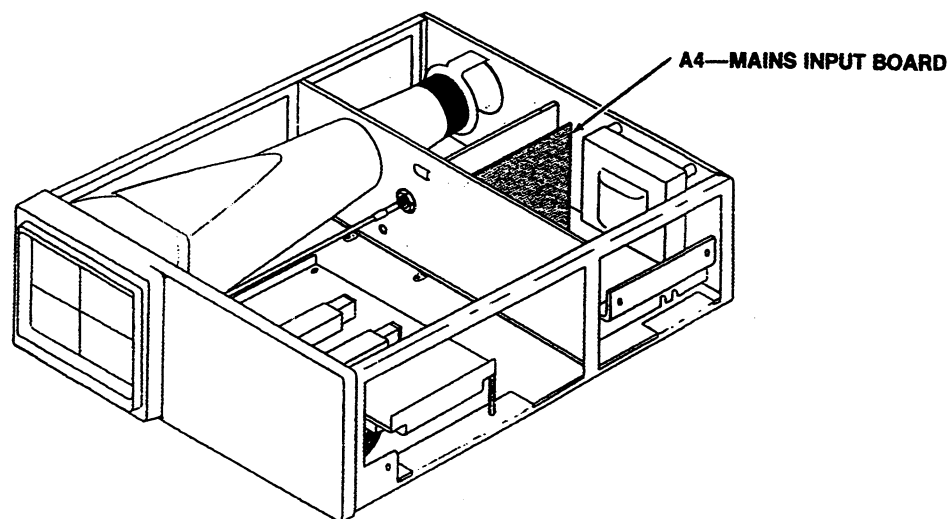

Figure 9-10. A4—Mains input board.

A4—MAINS INPUT BOARD					
CIRCUIT NUMBER	SCHEM NUMBER	CIRCUIT NUMBER	SCHEM NUMBER	CIRCUIT NUMBER	SCHEM NUMBER
C900	7			R903	7
C903	7	FS901	7	R904	7
C904	7			R905	7
C905	7	J901	7	R906	7
C907	7	J902	7	R907	7
CR901	7	L901	7	S901	7
CR902	7	L902	7	S902	7
CR903	7				
CR904	7	Q900	7	W903	7
F901	7	R902	7		



 Static Sensitive Devices
See Maintenance Section

COMPONENT NUMBER EXAMPLE

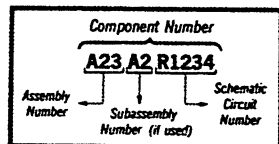

Chassis-mounted components have no Assembly Number prefix—see end of Replaceable Electrical Parts List.

FRONT PANEL CONTROLS DIAGRAM 6

ASSEMBLY A1											
CIRCUIT NUMBER	SCHEM LOCATION	BOARD LOCATION	CIRCUIT NUMBER	SCHEM LOCATION	BOARD LOCATION	CIRCUIT NUMBER	SCHEM LOCATION	BOARD LOCATION	CIRCUIT NUMBER	SCHEM LOCATION	BOARD LOCATION
J1	1B	1F	J3	3B	12B	J6	5L	1A			
J2	2B	1E	J5	3L	1B						
Partial A1 also shown on diagrams 2, 3, 4, 5, 7 and 8.											
ASSEMBLY A2											
CIRCUIT NUMBER	SCHEM LOCATION	BOARD LOCATION	CIRCUIT NUMBER	SCHEM LOCATION	BOARD LOCATION	CIRCUIT NUMBER	SCHEM LOCATION	BOARD LOCATION	CIRCUIT NUMBER	SCHEM LOCATION	BOARD LOCATION
AT1	2L	5B	J7	5B	2D	R3	2L	5D			
AT51	2L	5D				R53	2L	5D			
Partial A2 also shown on diagrams 1, 5 and 8.											
ASSEMBLY A3											
CIRCUIT NUMBER	SCHEM LOCATION	BOARD LOCATION	CIRCUIT NUMBER	SCHEM LOCATION	BOARD LOCATION	CIRCUIT NUMBER	SCHEM LOCATION	BOARD LOCATION	CIRCUIT NUMBER	SCHEM LOCATION	BOARD LOCATION
C2	1J	4C	J987**	8B	2A	R377	7J	2F	S362	7J	3F
C52	3J	4C				R378	8H	2E	S401	5G	2F
C377	8J	2E	R2	1J	4B	R379	8H	2E	S460	4D	1F
C378	8H	2E	R4	1J	4B	R383	8K	4F	S506	4K	2F
C383	7K	4E	R52	3J	4C	R426	4C	1F	S545	2H	2C
C392	7K	2F	R54	3J	4C	R726	7C	1E	S550	2G	2B
CR401	5G	2F	R84	6E	3C	R800	1E	2A	S555	4H	3F
CR534	3F	2B	R89	5D	2C	R802	1E	1A	S801	7F	2E
CR537	3G	2B	R92	5C	2D	R986	8E	3A			
CR538	2E	2B	R94	5C	2C	R987	8D	2A	W1	1C	4A
			R113	2D	1B				W2	2C	2A
			R123	2D	1B	S90	5E	2C	W3	3C	4D
DS370	8K	4A	R153	2D	1C	S101	1K	3B	W5	3L	4E
DS370	8E	4A	R173	2C	1C	S201	3K	3C	W6	6L	4F
DS560	8K	2F	R385	8F	3A	S390	1C	2A	W7	5C	3D
R378	8J	3F									
Partial A3 also shown on diagrams 1, 2, 3, 4 and 8.											
CHASSIS MOUNTED PARTS											
CIRCUIT NUMBER	SCHEM LOCATION	BOARD LOCATION	CIRCUIT NUMBER	SCHEM LOCATION	BOARD LOCATION	CIRCUIT NUMBER	SCHEM LOCATION	BOARD LOCATION	CIRCUIT NUMBER	SCHEM LOCATION	BOARD LOCATION
J100	1L	CHASSIS	J300	8L	CHASSIS	R1	1K	CHASSIS	R382	7L	CHASSIS
J151	3L	CHASSIS				R51	3K	CHASSIS			

**Not in Electrical Parts List

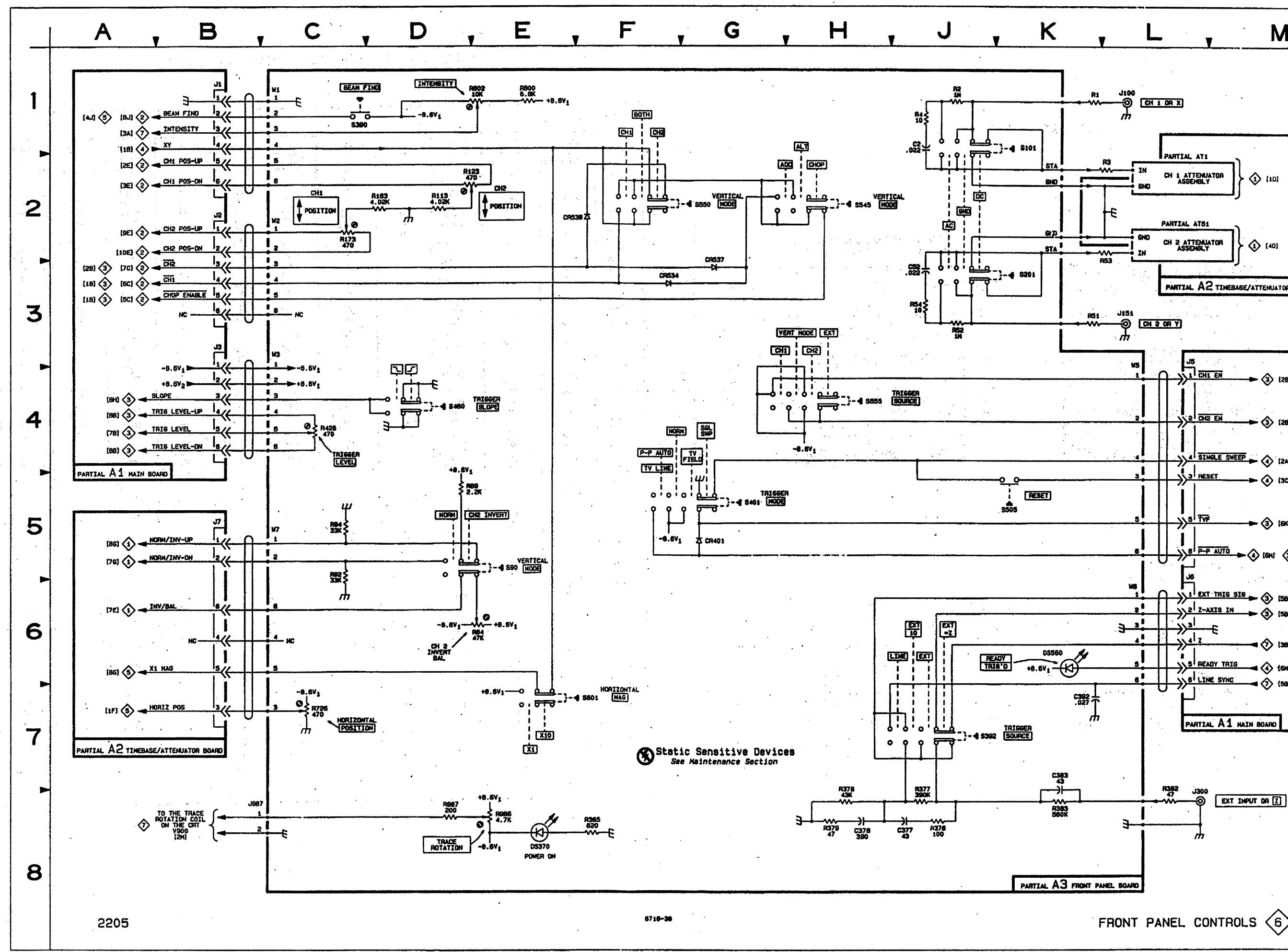

POWER SUPPLY, Z-AXIS, & CRT DIAGRAM 7

WAVEFORMS FOR DIAGRAM 7

AC Waveforms

SEC/DIV 20 μ s

1 VOLT PER DIVISION EQUALS 1 AMP PER DIVISION FOR WAVEFORM 7F

WAVEFORMS FOR DIAGRAM 7

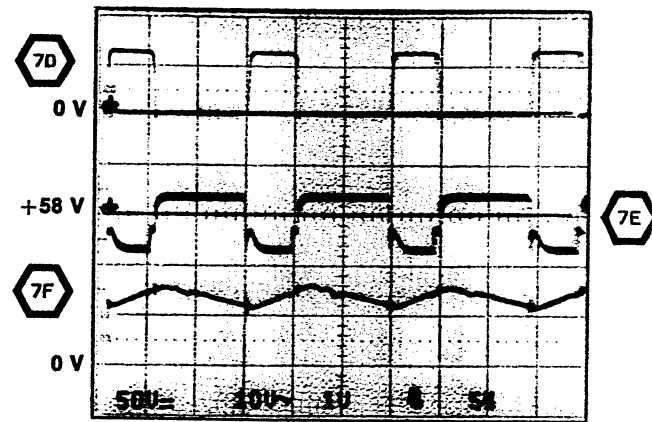
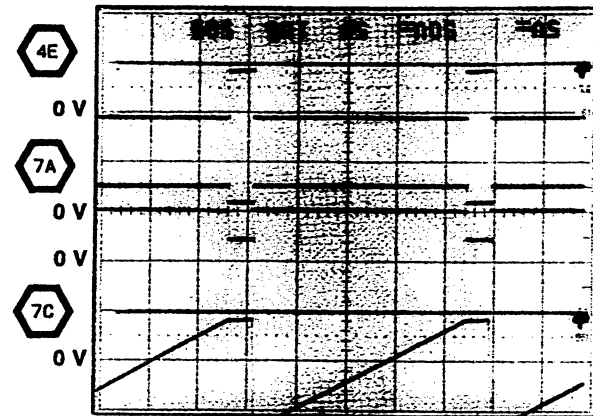

1 VOLT PER DIVISION EQUALS 1 AMP PER DIVISION FOR WAVEFORMS 7I AND 7J

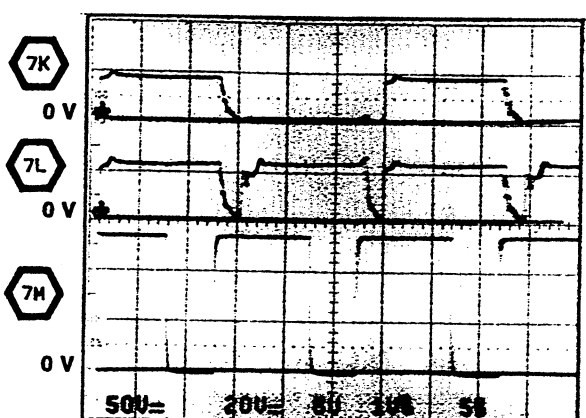
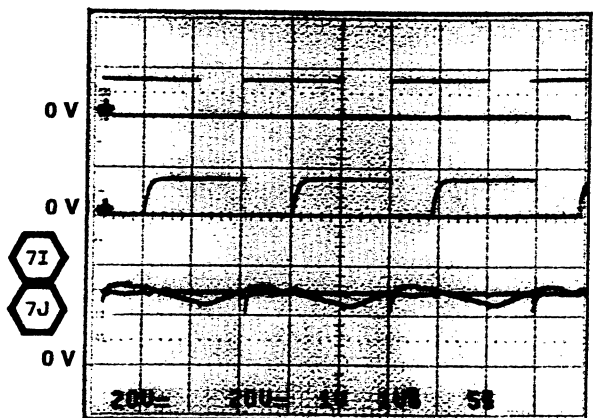

6716-32

ASSEMBLY A1

CIRCUIT NUMBER	SCHEM LOCATION	BOARD LOCATION	CIRCUIT NUMBER	SCHEM LOCATION	BOARD LOCATION	CIRCUIT NUMBER	SCHEM LOCATION	BOARD LOCATION	CIRCUIT NUMBER	SCHEM LOCATION	BOARD LOCATION
C824	3D	6G	CR942	8J	8A	R832	1E	7H	R846	8H	8A
C828	3E	7J	CR945	8K	8C	R834	3F	7J	R847	9H	9B
C832	1E	8H	CR946	8J	8A	R834	4F	7J	R848	7H	8B
C834	4F	7J	CR947	5K	10B	R835	3E	7J	R849	6K	10F
C835	3F	8J	CR950	5H	10B	R836	3E	7J	R855	6F	11B
C845	3F	8J	CR975	5K	10E	R840	3F	8H	R856	7H	8B
C847	2G	8J	CR976	5K	11E	R841	2F	8H	R857	10H	9B
C849	1G	8J	CR980	6F	9D	R842	2G	8G	R858	7G	8B
C851	4H	7F	CR981	6E	9D	R843	3F	7J	R870	6E	10C
C853	4J	8G	CR982	7L	9F	R844	2F	8J	R871	6J	8C
C854	3J	8G	CR983	8L	9E	R845	2F	8J	R872	6E	9D
C855	2G	9G	CR984	8L	9E	R849	1G	8J	R877	5C	9C
C871	4L	6F	CR985	8L	9E	R850	3H	8F	R878	4J	10G
C875	3K	7G	CR986	8L	9E	R851	3H	8E	R879	3E	7J
C893	2L	9H	CR987	9K	8C	R852	4H	6E	R880	6J	8C
C901	5B	6A	CR988	9K	8C	R853	4J	8G	R881	6D	9D
C902	5B	2A	CR989	9L	8C	R854	3J	8G	R882	6E	9C
C914	8E	11C	CR990	7K	9E	R855	3H	6E	R883	5E	9C
C915	9G	10D	CR991	7K	9E	R858	2J	10G	R884	2J	8C
C920	10F	11D				R860	2H	10G	R884	5E	9C
C925	9E	11C	DS856	2H	10G	R870	4K	6F	R885	6D	9C
C930	7F	11B	DS858	2H	10G	R871	3K	7G	R886	5D	9C
C932	5E	10B				R874	3K	7G	R887	6D	9D
C933	6G	10B	L850	5H	9B	R875	3K	7G	R888	6D	9D
C935	6G	10B	L888	9L	7B	R888	3J	8G	R889	7D	9D
C941	7H	8B	L888	9L	8C	R889	3J	8G	R890	10M	6E
C942	8J	8C	L890	7L	7E	R890	2J	8G	R891	10M	8E
C943	7J	8B				R891	2J	9G	R892	10M	9C
C945	9H	9B	P900**	5L	9G	R892	2J	9G	R895	5K	9E
C946	8J	9B	P901**	4L	9G	R894	2J	9G			
C952	7E	8B	P902**	4L	9G	R899	5B	2A	T802	5K	9D
C974	3E	7J	P903**	4L	7F	R900	5B	2A			
C976	5J	11G				R901	5B	6A	U910A	8F	10C
C978	4J	11G	Q804	3C	6G	R910	8H	9B	U910B	9F	10C
C980	5K	10E	Q817	2C	5H	R911	8G	10C	U820	8D	11C
C982	6E	10D	Q818	3C	4G	R912	8F	10C	U830	8F	10B
C983	8L	7E	Q825	1D	7H	R913	8F	10C	U840	7G	7A
C984	8L	8F	Q829	2E	8H	R914	8E	11C			
C985	8L	8E	Q835	3F	8J	R915	9G	11D	VR915	9G	11D
C986	8L	7B	Q840	3G	8H	R916	9G	10D	VR925	9D	10C
C987	9M	7B	Q845	2G	8H	R917	9G	10D	VR932	5F	10B
C988	9L	7C	Q832	6F	10A	R918	9G	11D	VR933	5F	10B
C989	9M	7C	Q833	5G	10A	R919	10F	10C	VR982	6E	9D
C990	7L	8E	Q835	7G	10B	R920	9F	10C	VR985	5D	9C
C991	7L	7D	Q839	6H	8C	R922	9F	10C	VR988	7D	9C
C992	10M	6E	Q841	7J	8A	R926	9D	11C			
			Q842	7J	8A	R927	8D	11C	W90	9M	8D
CR817	2C	6H	Q843	9H	9B	R928	8D	11D	W893	2L	9G
CR818	2D	6G	Q845	9J	9A	R929	8E	11C	W803	6B	9C
CR820	3D	6G	Q846	8J	9A	R930	7F	11B	W820	9E	10C
CR824	1E	7H	Q882	6E	9D	R931	7F	11B	W821	10F	11D
CR825	1E	7H	Q885	6E	9C	R932	7F	11B	W825	10E	10C
CR827	2E	7J	Q888	6D	9D	R933	6G	10B	W826	10E	10C
CR828	3E	7J				R934	5F	10B	W847	7K	8B
CR829	2E	7H	R804	3C	5G	R935	7F	11B	W848	8K	8B
CR840	3F	8J	R805	2C	6G	R936	7G	9B	W851	5G	10A
CR845	2F	8J	R818	2D	6G	R939	7H	8B	W876	5J	10F
CR851	3H	8F	R819	1C	6G	R940	6J	8B	W884	8M	6E
CR853	3H	8G	R820	2D	6G	R941	6J	8B	W885	8M	6E
CR854	2J	9G	R822	3D	2D	R942	7H	8A	W887	9M	6D
CR855	2H	9G	R823	3D	6G	R943	8H	8B	W889	9M	6C
CR833	7G	10B	R825	1D	6G	R944	9J	9B	W891	7M	6D
CR941	8K	8C	R830	2E	7H	R945	9J	9B			

Partial A1 also shown on diagrams 2, 3, 4, 5, 6 and 8.

**Not in Electrical Parts List

MORE

POWER SUPPLY, Z-AXIS, & CRT DIAGRAM 7 (CONT)

ASSEMBLY A4											
CIRCUIT NUMBER	SCHEM LOCATION	BOARD LOCATION	CIRCUIT NUMBER	SCHEM LOCATION	BOARD LOCATION	CIRCUIT NUMBER	SCHEM LOCATION	BOARD LOCATION	CIRCUIT NUMBER	SCHEM LOCATION	BOARD LOCATION
C900	6C	2D	CR904	7B	1C	L901	6B	3C	R905	6B	1D
C903	6B	3C				L902	6B	1B	R906	7B	1D
C904	6C	3D	FR01	6B	1A	Q900	6B	1D	R907	7B	1C
C905	6B	3B							S901	6C	4C
C907	7B	1C	FS001	6B	1A	R902	7B	1D	S902	6C	4A
CR901	7B	1D	J901	10B	2A	R903	6C	1D	W903	6B	1D
CR902	7B	1C	J902	7B	2B						
CR903	7B	1C									

CHASSIS MOUNTED PARTS											
CIRCUIT NUMBER	SCHEM LOCATION	BOARD LOCATION	CIRCUIT NUMBER	SCHEM LOCATION	BOARD LOCATION	CIRCUIT NUMBER	SCHEM LOCATION	BOARD LOCATION	CIRCUIT NUMBER	SCHEM LOCATION	BOARD LOCATION
P902	7A	CHASSIS	R993	2L	CHASSIS	T901	7A	CHASSIS	V900	1N	CHASSIS
P908	3L	CHASSIS									
P910	2M	CHASSIS									

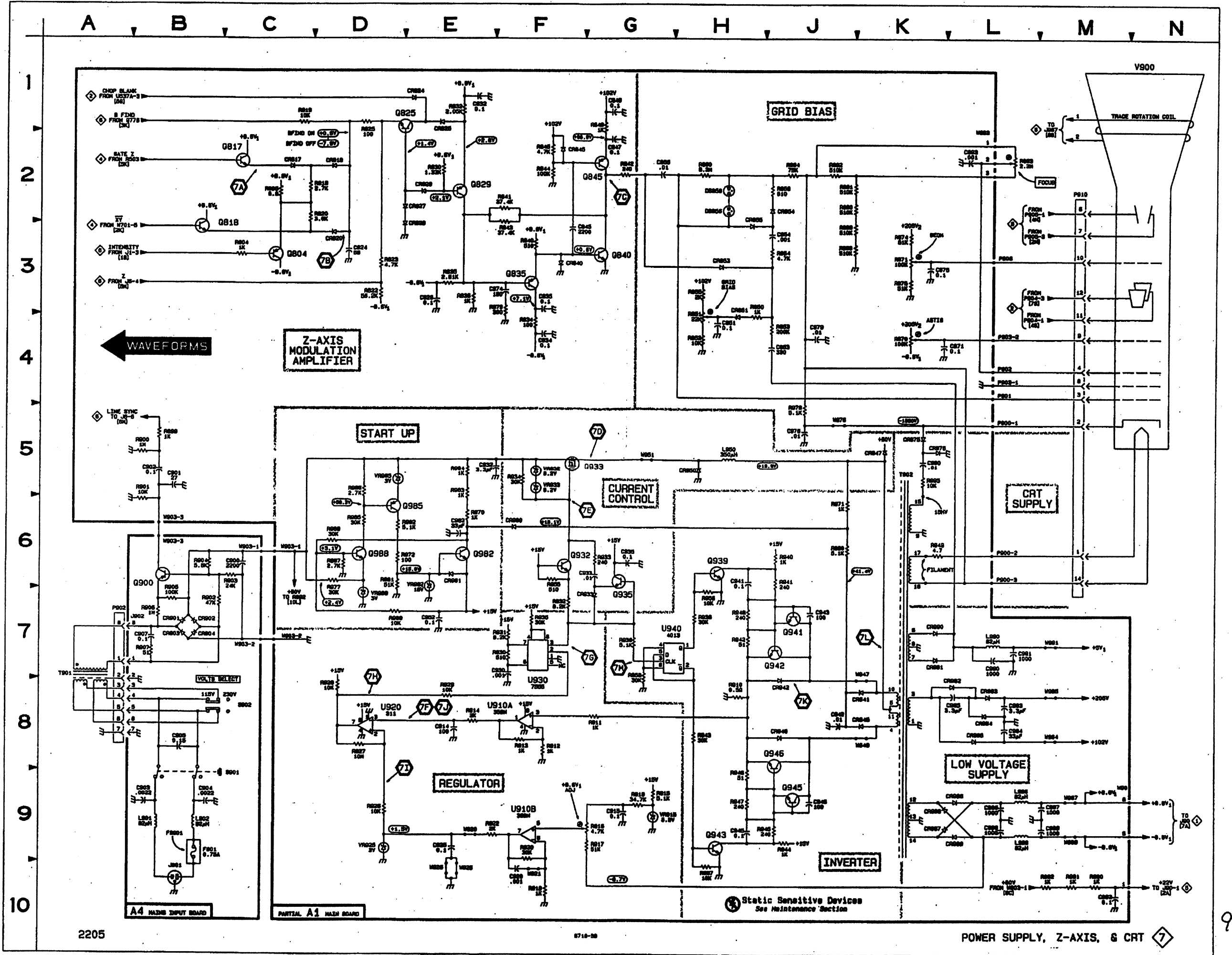

2205

8710-20

POWER SUPPLY, Z-AXIS, & CRT 7

9-20

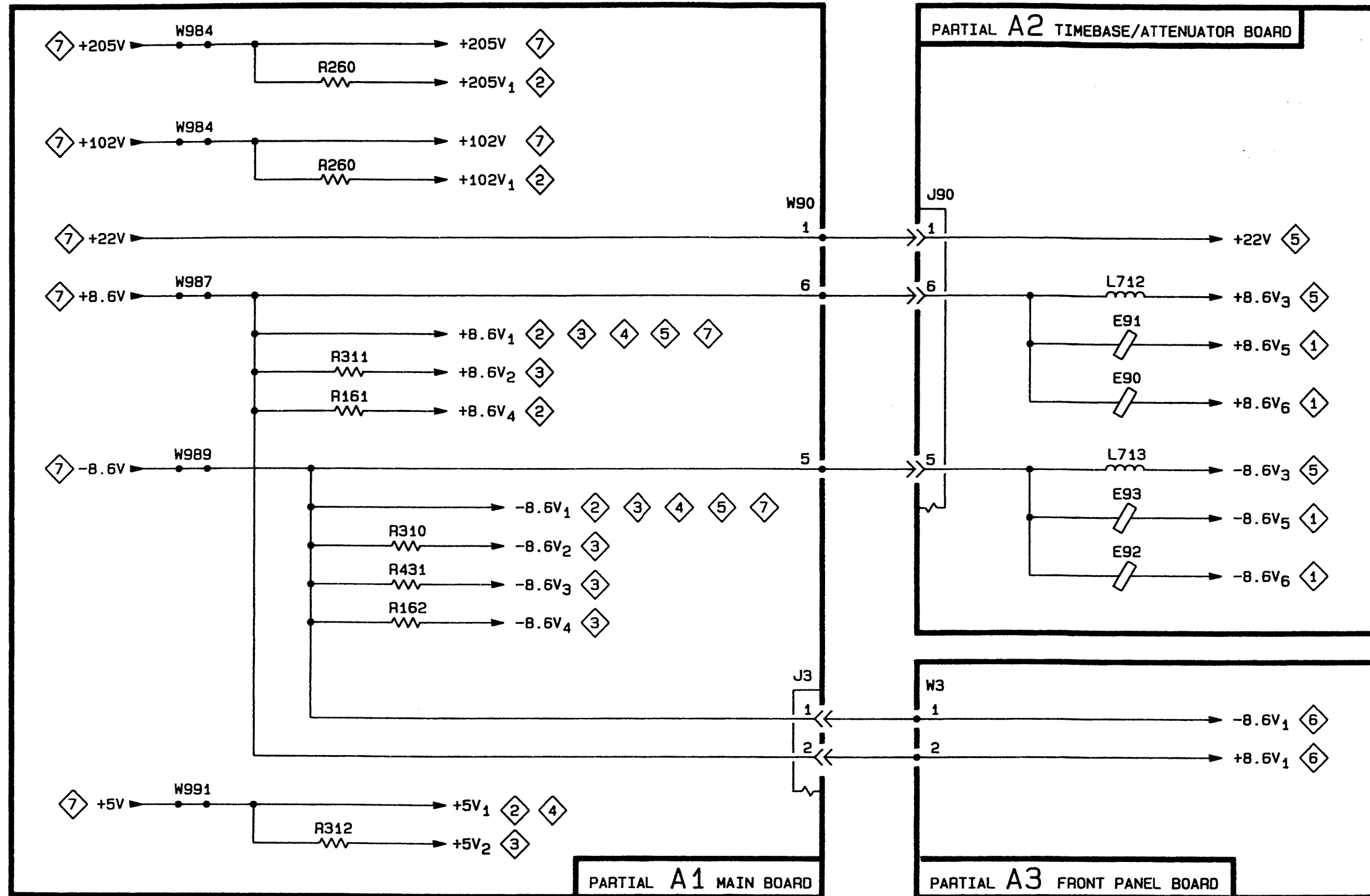

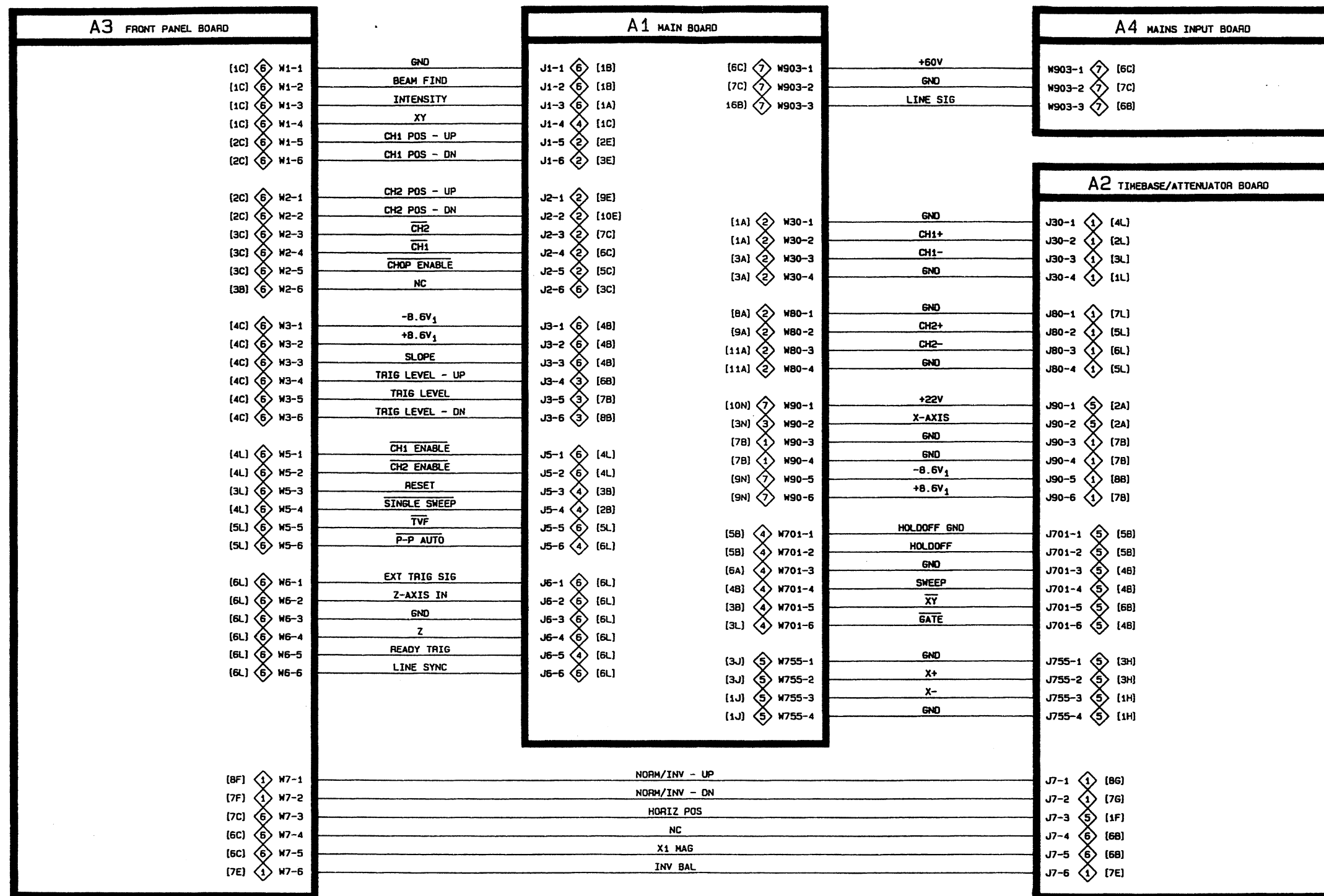

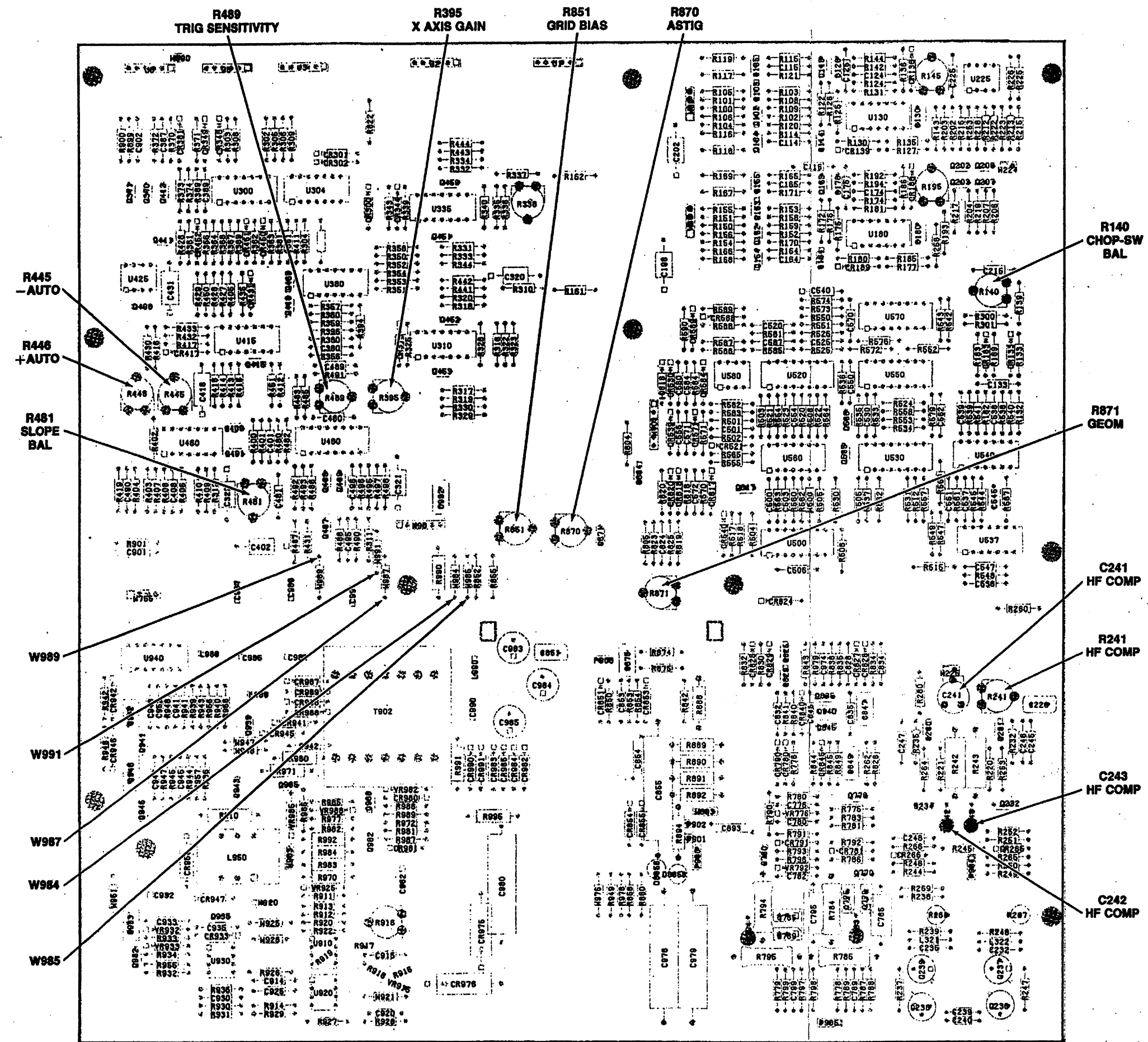

Figure 9-11. Adjustment locations of A1—Main board component view.

6716-27

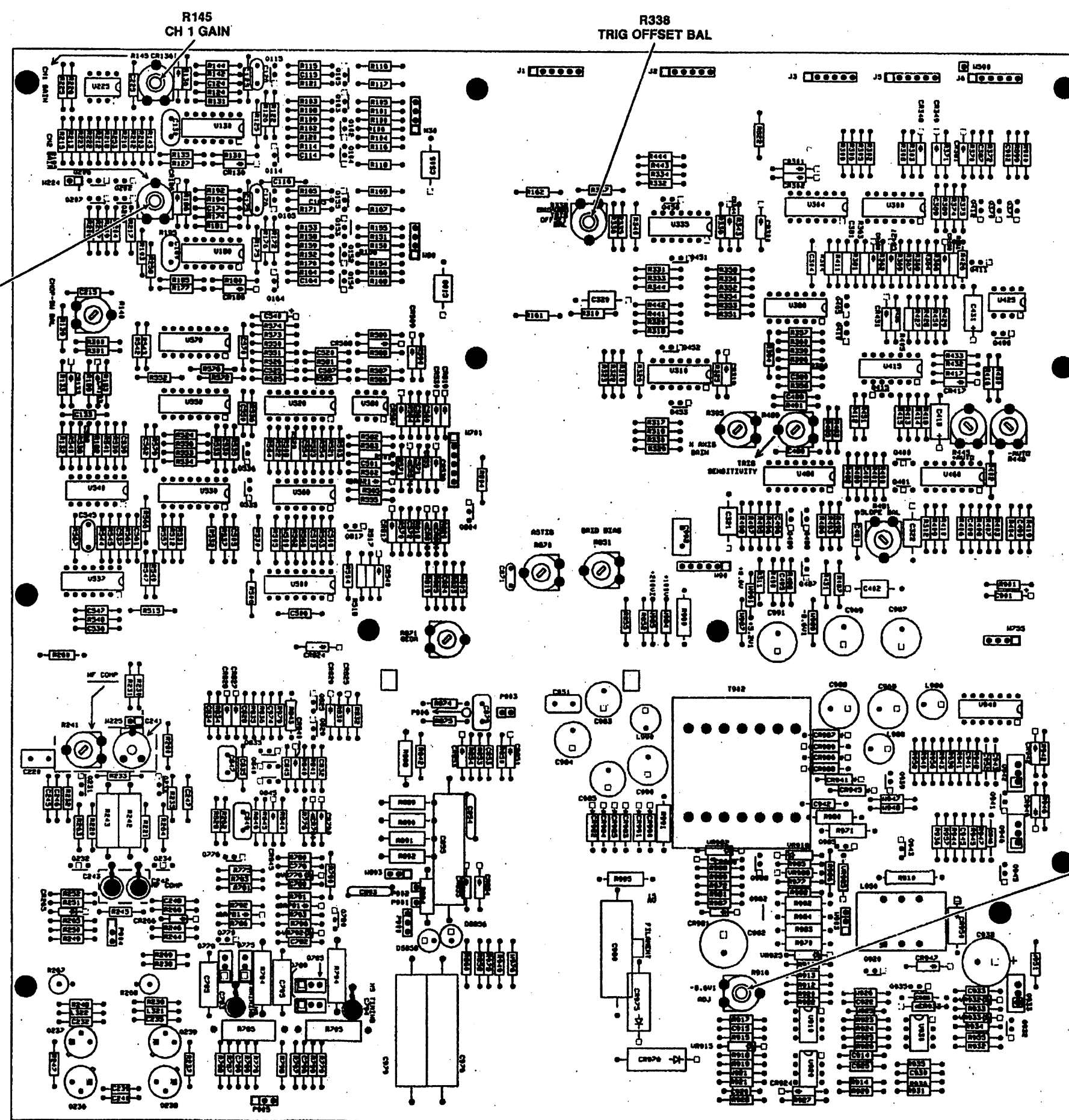

Figure 9-12. Adjustment locations of A1—Main board circuit view.

6716-28

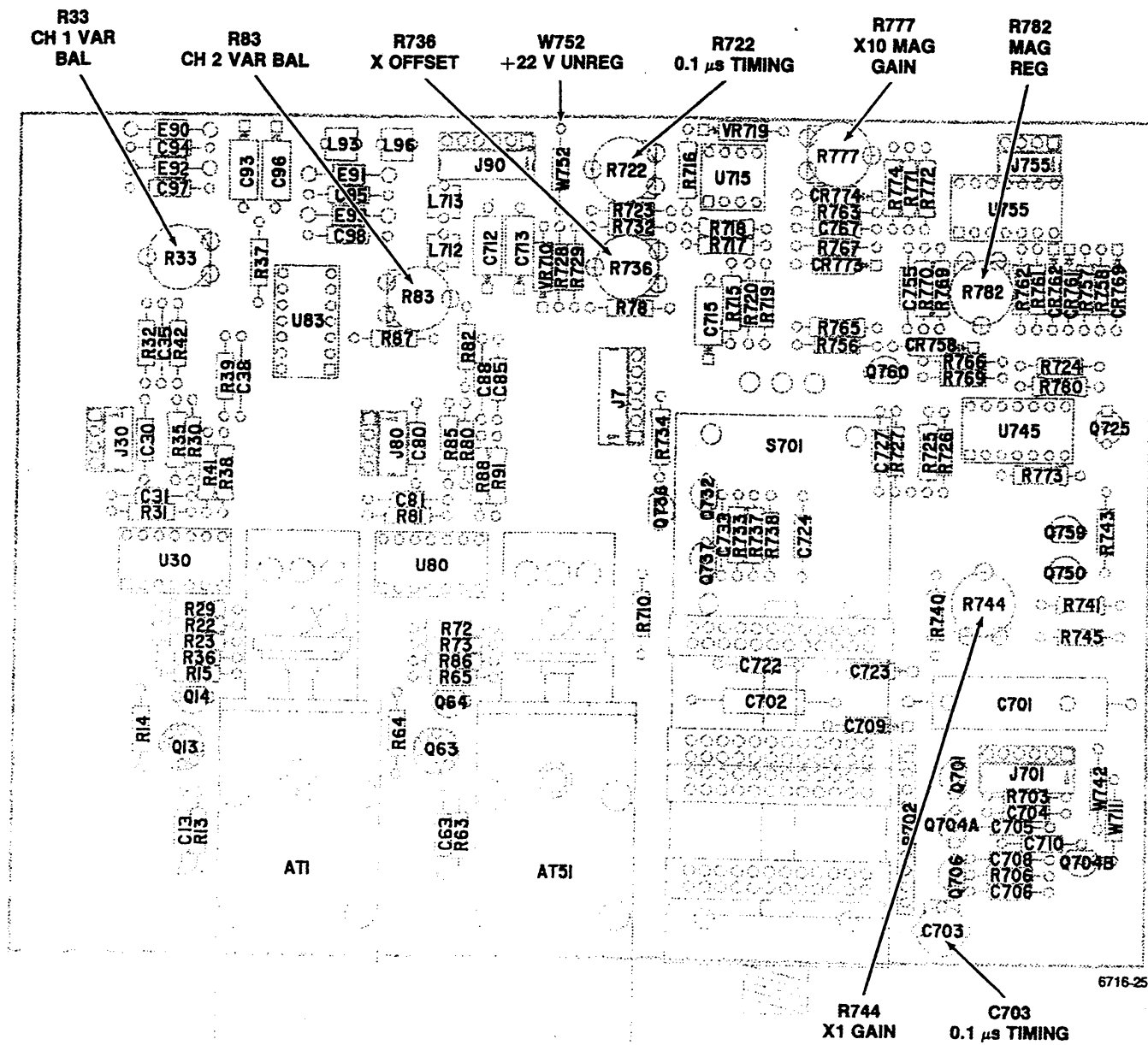

Figure 9-13. A2—Timebase/Attenuator board adjustment locations.

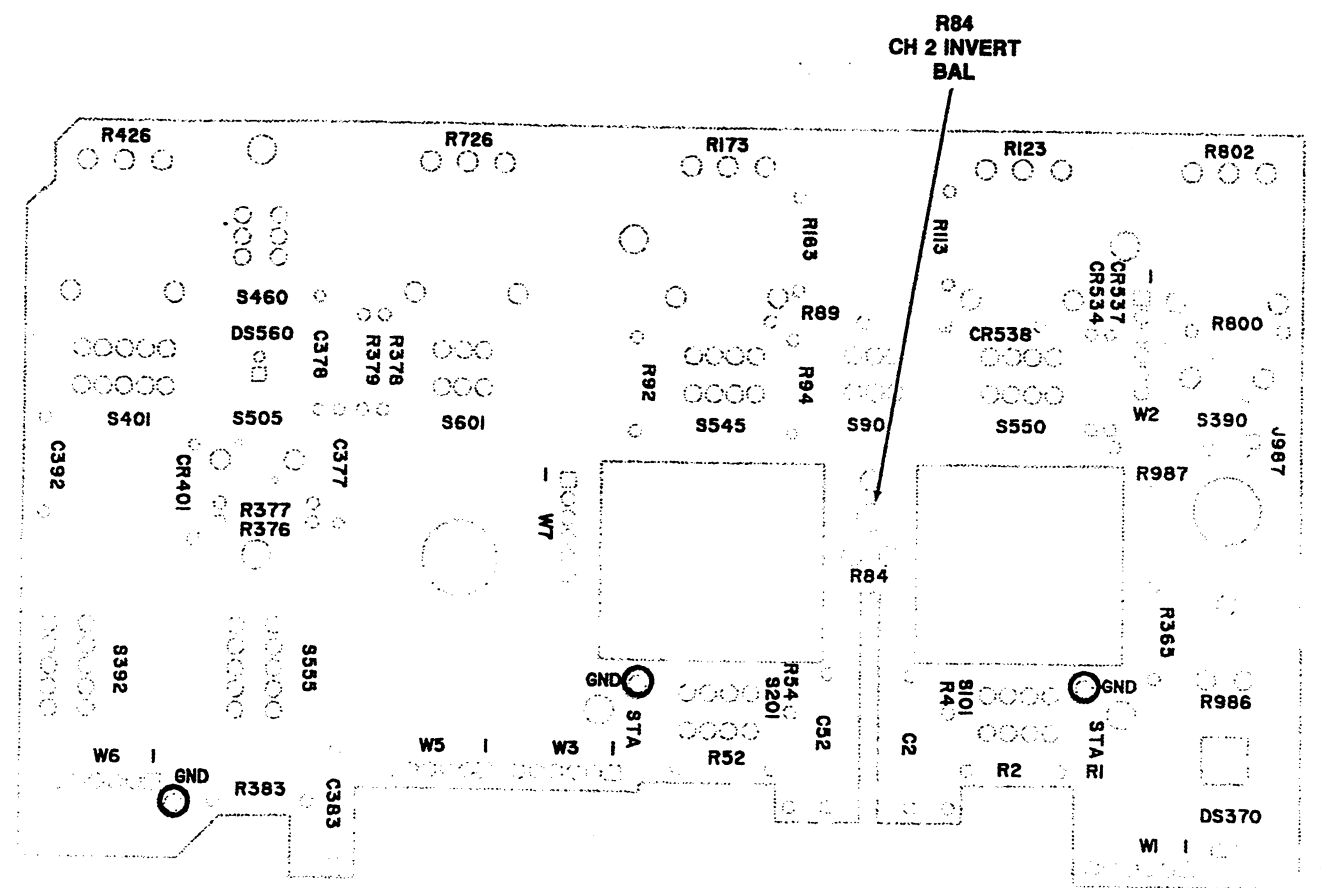
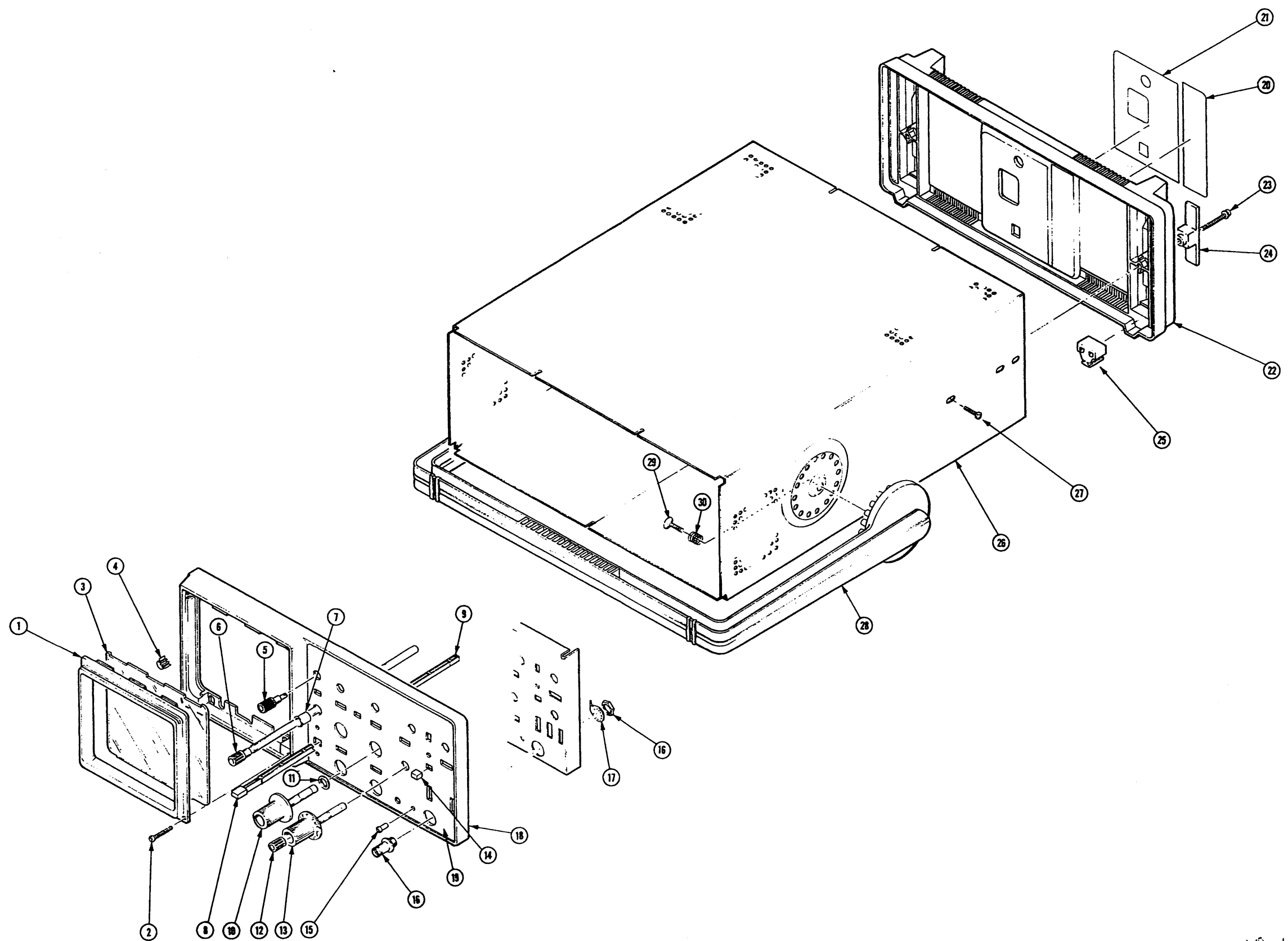
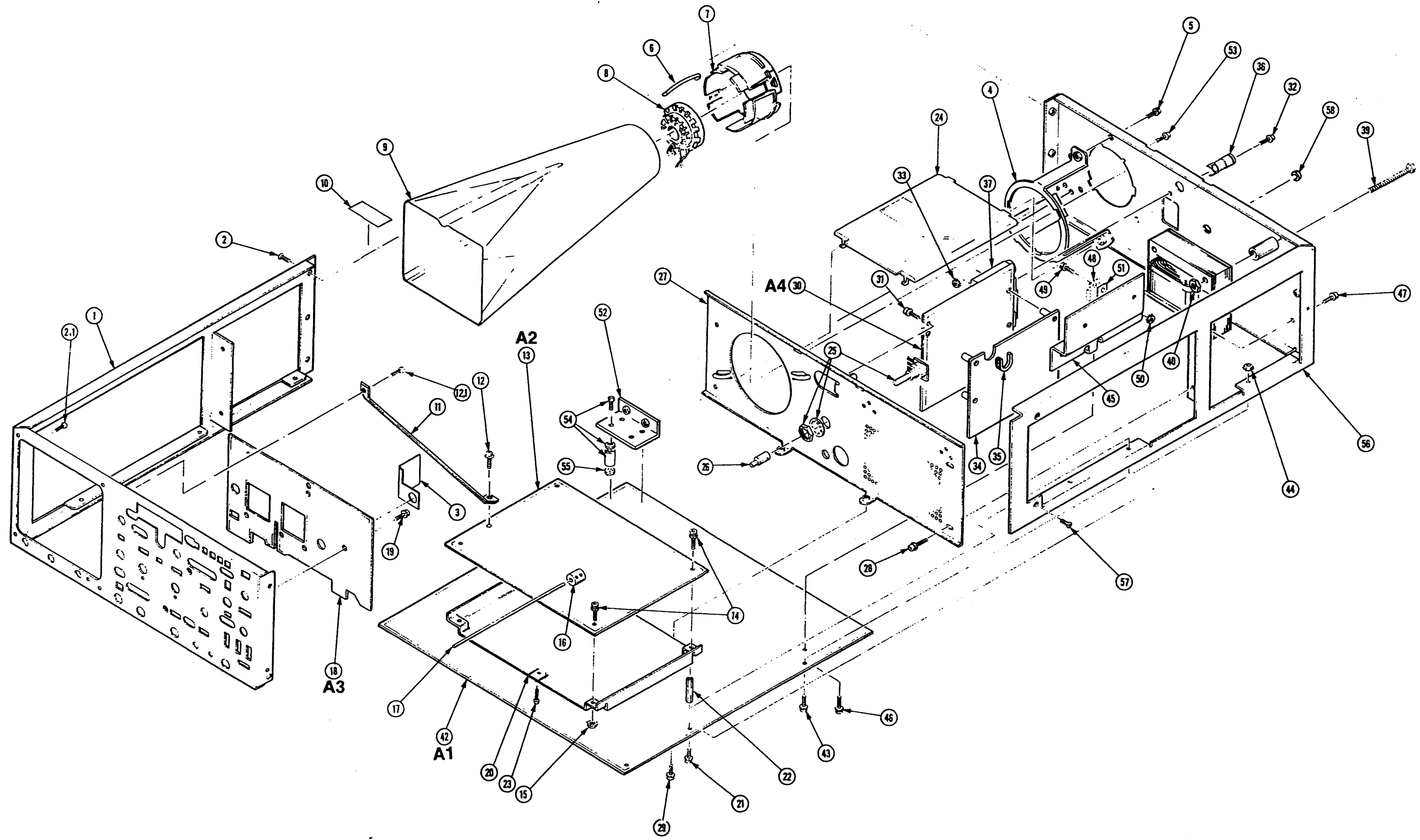

Figure 9-14. A3—Front Panel board adjustment location.



10-49
2205 Service



10-46

2205 Service